

SMART MINI AUTOMATIC VACUUM CLEANER USING PIC
MICROCONTROLLER

MOHAMAD SHAIFUL FAIZ BIN ABD RAHIM

This Report Is Submitted In Partial Fulfillment of Requirements For
The Bachelor Degree in Electronic Engineering (Computer Engineering)

Fakulti Kejuruteraan Elektronik dan Kejuruteraan Komputer
Universiti Teknikal Malaysia Melaka

June 2015



UNIVERSITI TEKNIKAL MALAYSIA MELAKA
FAKULTI KEJURUTERAAN ELEKTRONIK DAN KEJURUTERAAN KOMPUTER

BORANG PENGESAHAN STATUS LAPORAN
PROJEK SARJANA MUDA II

Tajuk Projek : **SMART MINI AUTOMATIC VACUUM CLEANER**
USING PIC MICROCONTROLLER

Sesi Pengajian :

1	4	/	1	5
---	---	---	---	---

Saya **MOHAMAD SHAFUL FAIZ BIN ABD RAHIM** mengaku membenarkan Laporan Projek Sarjana Muda ini disimpan di Perpustakaan dengan syarat-syarat kegunaan seperti berikut:

1. Laporan adalah hakmilik Universiti Teknikal Malaysia Melaka.
2. Perpustakaan dibenarkan membuat salinan untuk tujuan pengajian sahaja.
3. Perpustakaan dibenarkan membuat salinan laporan ini sebagai bahan pertukaran antara institusi pengajian tinggi.
4. Sila tandakan () :

SULIT*

*(Mengandungi maklumat yang berdarjah keselamatan atau kepentingan Malaysia seperti yang termaktub di dalam AKTA RAHSIA RASMI 1972)

TERHAD**

** (Mengandungi maklumat terhad yang telah ditentukan oleh organisasi/badan di mana penyelidikan dijalankan)

TIDAK TERHAD

Disahkan oleh:

 (TANDATANGAN PENULIS)

 (COP DAN TANDATANGAN PENYELIA)

Tarikh:

Tarikh:

“I hereby that this report is the result of my own work except for quotes as cited in the references.”

Signature :
Author : MOHAMAD SHAFUL FAIZ BIN ABD RAHIM
Date : 10 JUNE 2015

“I hereby declare that I have read this and in my opinion this report is sufficient in term of the scope and quality for the award of Bachelor of Electronics Engineering.”

Signature :

Author : EN. NORIZAN BIN MOHAMAD

Date : 10 JUNE 2015

To my beloved parents and siblings:

Abd Rahim Bin Nayan

Asiah Binti Talib

Shahfarin

Fazwan

Haikal

Fitri

ACKNOWLEDGEMENT

Praise to Allah S.W.T that with His blessings I am able to finish this project in time successfully. I would like to express my greatest gratitude to my supervisor Mr Norizan Bin Mohamad for his guidance in finishing this project. My next deepest appreciation is dedicated to my parents and family for their money and moral support. Thanks to my friend who had helped me a lot in finishing this project. Last but not least to whom directly or indirectly contribute to this project.

ABSTRACT

A Robot Vacuum Cleaner is design to help people to complete their task. This project intend to design a smart mini robot vacuum cleaner by using 18F4550 PIC Microcontroller as a platform for the controlling input and output device. The existing robot vacuum cleaner is expensive and bigger in size. The purpose of this project is to design and implement a Vacuum Robot. Vacuum Robot is designed to make cleaning process become easier rather than by using manual vacuum. The idea is basically by having the sensor to detect any object and send the output to a PIC that will control the Vacuum Robot movement. By using Vacuum Robot, user can just turn on the Vacuum Robot to clean without having to monitor the Robot. The methodology and scope of study are performed by doing literature reviews and research on various sensors, motor, PIC, and the programming of the PIC. Vacuum Robot will have several criteria that are efficient, organized and user-friendly, which meets human needs.

ABSTRAK

Robot Vakum direka untuk membantu orang ramai untuk menyelesaikan tugas mereka. Projek ini bertujuan mencipta vakum robot mini dengan menggunakan PIC 18F4550 mikropengawal sebagai platform untuk input dan output. Vakum robot yang sedia ada lebih mahal dan bersaiz besar. Tujuan projek ini dijalankan adalah untuk mereka bentuk Robot Vakum. Robot vakum yang direka memudahkan proses pembersihan jika dibandingkan dengan menggunakan vakum manual. Robot Vakum ini mempunyai sensor untuk mengesan objek dan menghantar input kepada PIC yang akan mengawal pergerakan Robot Vakum tersebut. Dengan menggunakan Robot Vakum, pengguna hanya menghidupkan Robot Vakum untuk tujuan pembersihan dan tanpa perlu diperhatikan. Metodologi dan skop kajian dilakukan dengan melakukan tinjauan kesusasteraan dan penyelidikan mengenai sensor, motor, dan pengaturcaraan PIC. Robot Vakum ini mempunyai beberapa kriteria seperti kecekapan yang tinggi, teratur dan mesra pengguna, yang memenuhi keperluan manusia.

TABLE OF CONTENTS

CHAPTER	TITLE	PAGE
	PROJECT TITLE	i
	DECLARATION	ii
	DEDICATION	v
	ACKNOWLEDGEMENT	vi
	ABSTRACT	vii
	TABLE OF CONTENTS	ix
	LIST OF TABLE	xii
	LIST OF FIGURES	xii
	LIST OF GRAPH	xvi
I	INTRODUCTION	1
1.1	Introduction of Project	1
1.2	Objectives of Project	2

1.3	Problem Statements	3
1.4	Scope of Project	3
1.4.1	Software Design	4
1.4.2	Target User	4
1.4.3	Project Significance	5
1.5	Thesis Outline	5
II	LITERATURE REVIEW	7
2.1	Introduction to The Principle Of Vacuum Physics	7
2.2	How Does Conventional Vacuum Cleaner Works	8
2.3	A Maze Robot	10
2.4	Materials Uses	12
III	METHODOLOGY	14
3.1	Project Implementation	14
3.1.1	Input Devices	17
3.1.2	Output Devices	19
3.1.2.1	Dc Motor	19
3.1.2.2	Alarm	19
3.1.2.3	Vacuum Motor	20
3.1.2.4	Microcontroller	20

3.2	Design of Circuit	22
3.3	Software Description	28
3.3.1	PIC C Compiler	28
3.3.2	Proteus	31
3.3.3	Bootloader	33
IV	RESULT AND DISCUSSION	34
4.1	Results	34
4.1.1	Hardware Part of Prototype	34
4.1.2	Analysis of IR sensor	42
4.1.3	Pulse Width Modulation (PWM)	44
4.2	Discussion	46
V	CONCLUSION AND RECOMMENDATION	49
5.1	Conclusion	50
5.2	Recommendation	51
	References	52
	Appendices	
	Appendix A	
	Appendix B	

LIST OF TABLES

NO	TITLE	PAGE
4.9	The Output of IR Sensor When the Distance Between the Obstacles is Apply	42
6.0	Operation In C Programming	54

LIST OF FIGURES

NO	TITLE	PAGE
1.1	Block Diagram of Robot Vacuum Cleaner	3
2.1	Conventional Vacuum Cleaner Works	8
2.2	Vacuum Cleaner for Wet and Dry Design	9
2.3	System Design of Robot	10
2.4	How The Robot Works	11
2.5	The Duty Cycle	13
3.1	Flow Chart for Software Project Implementation	15
3.2	Flow Chart for Hardware Project Implementation	16
3.3	IR Sensor and Metal Detector	17
3.4	IR Sensor Works	18
3.6	H-Bridge and DC Motor	19
3.7	Buzzer	19
3.8	PIC 18F4550 Pins Diagram	21
3.9	Information of PIC 18F4550	21
3.10	Schematic Circuit Designed in ISIS	22

3.11	Schematic Circuit Designed DC Motor Driver and IR Sensor in ISIS	23
3.12	PCB Layout- Top Copper	24
3.13	PCB Layout-Bottom Copper	24
3.14	PCB IR Sensor Layout- Top Copper	25
3.15	PCB IR Sensor Layout- Bottom Copper	25
3.16	PCB DC Motor Driver Layout – Top Copper	25
3.17	PCB DC Motor Driver Layout – Bottom Copper	26
3.18	Microprocessor Board	27
3.19	IR Sensor Circuit	27
3.20	DC Motor Driver Circuit	27
3.21	PIC Compiler Icon	28
3.22	Declaration of Program	29
3.23	Example Coding for Operation	29
3.24	Icon of Proteus Software	31
3.25	Opening Project	31
3.26	Toolbars Menu	32
3.27	Object Selector in ISIS	32
3.28	Operation of Bootloader	33
4.1	Prototype of Robot vacuum Cleaner	35
4.2	Initialization to Activate ADC Channel	35
4.3	Voltage Input for PIC 18F4550	36

4.4	The Output of Motor When the Front Sensor is Trigger	37
4.5	The Output of Motor When the Right Sensor is Trigger	38
4.6	The Output of Motor When the Left Sensor is Trigger	39
4.7	The Output of Motor When the Bottom Sensor is Trigger	40
4.8	Movement of Robot Vacuum Cleaner	41
4.11	Initialization Used to Control the PWM of Motor	44
4.12	Simulation PWM of Motor	44
4.14	Initialization For The Analog Input in PIC 18F4550	46
4.15	Development Stage	47

LIST OF GRAPH

NO	TITLE	PAGE
4.10	The Graph of Decimal Value versus Distance	43

CHAPTER I

INTRODUCTION

Chapter 1 covers the introduction part of this Final Year Project of Degree. It contains subchapters of objectives, problem statements, scopes of project and methodology.

1.1 Introduction

With the development of science and technology, rapid development of robotic has been increasing from year to year. Using robot to fulfil human requirement is a part of life. Robots are developed as a home appliance recently as

the individuals requests are expanding. Home mechanical machine technology exploration is getting to be dynamic like never before. So far big vacuum cleaning machines are available for domestic and industrial use. But their operations are non-autonomous type and these can perform only some specific functions of cleaning.

A robot vacuum cleaner, frequently called a robovac, is an intelligent automated vacuum cleaner that has insightful programming and a constrained vacuum cleaning framework. Some designs use spinning brushes to reach the corners. Automated vacuums may be part of a more general purpose domestic robot. These robot are built to make less effort for human works especially to clean up the house.

This Robot Vacuum Cleaner is a device which can operate automatically and have ability to travel in every direction based on the instruction given by the programmer. This purpose of using Robot Vacuum Cleaner is to reduce human effort and give a better efficiency during operate.

1.2 Objective of Project

The main objective of this project is to develop and implement a vacuum robot prototype by using Microcontroller PIC 18F4550. To fulfil the goal of this project, gain knowledge about IR sensor, control motor circuit, PIC circuit, and compatible software is required. The project is aimed to meet the following objectives:

- 1) To design and implement a working mini robot vacuum cleaner prototype.
- 2) To design an instruction of high level language using PIC 18F4550 microcontroller.
- 3) To ensure user friendly vacuum robot.

1.3 Problem Statements

Nowadays, technologies are part of human life and help them in order to complete their tasks. People using sweep to clean the floor and most of people are working need to focus on their job and they did not have enough time to clean. Using conventional vacuum cleaner need a lot of effort and supervision from the user, thus to overcome this problem they need a robot vacuum cleaner to done their job. Most of conventional robot vacuum cleaners in market are expensive and large in size. So it is difficult to clean anywhere. Furthermore user was busy to observe their robot during cleaning process, and can wasted energy. Therefore, this project is built to be one of the advantages for human which is to clean the floor within small period and less supervision.

1.4 Scope of Project

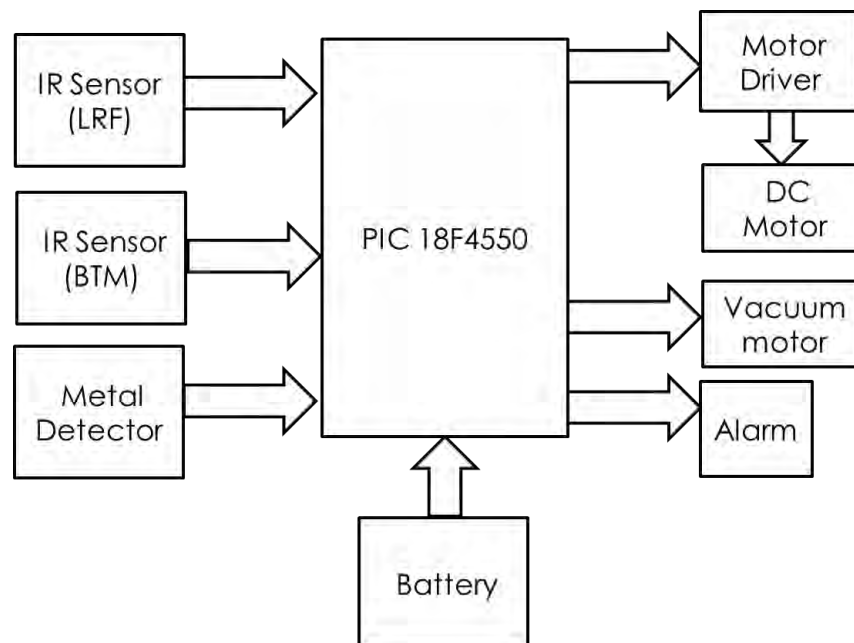

Figure 1.1: Block Diagram of Robot Vacuum Cleaner

This project used a PIC 18F4550 as a platform in order to design robot vacuum cleaner. Based on figure 1.1, implement IR sensor and metal detector as an input of this robot to detect obstacle and metal which can interference path of robot. The output of this robot vacuum cleaner is the motor, and alarm which linked to PIC microcontroller. The robot vacuum cleaner was controlled by the PIC microcontroller which create the peripheral between input and output. The power source was supply to PIC and DC motor as power to drive the robot vacuum cleaner. Figure 1.1 shows the block diagram of robot vacuum cleaner which divides into two parts, input and output peripheral.

1.4.1 Software Design

The software design used to build this robot vacuum cleaner is PIC compiler which enables the user to write an instruction of C programming. The Proteus is software used to design simulation of circuit. So it is a better way to simulate first rather than apply it to hardware because once the part of hardware is damage, it need to be replace with a new part and thus it need cost to replace it. The bootloader is a software that used to transfer the coding from that design in PIC Compiler into PIC 18F4550 microcontroller.

1.4.2 Target User

The conventional robot vacuum cleaner in the market are expensive and large in size. The optimal power suction of robot vacuum cleaner should be around 30W [4]. Compare to conventional vacuum cleaner, the power suction is 500-1000W [6] and for sure the power suction is higher compare to robot vacuum cleaner. The price

of robot vacuum cleaner seems not worth to its efficiency. Thus the robot vacuum cleaner that I develop is much more cheaper compare other robot vacuum cleaner in the market which have added some more features.

1.4.3 Project Significant

This robot vacuum cleaner is cheaper compare to other conventional robot vacuum cleaner in the market. The size of the robot vacuum cleaner is 17cm(L)x15cm(W), Thus it designed to be used at specific area such as floor and table. To design this project all the aspect need to be consider included planning, research, material selection, constructing prototype and lastly testing the all the integrated hardware that have been developed.

A working prototype mini robot vacuum cleaner will easier human task especially for the people who are busy and does not have time to clean their house especially on floor. This product was design to be use for indoor purpose.

This product can save energy and it can operate under minimum supervision. This product will be different from other conventional vacuum robot because it is cheap and small besides it have been added some features which is anti falls, automatic off after finished cleaning and can detect metal.

1.5 Thesis Outline

This report is consists of five parts. For chapter one section concentrates on the project background, problem statement, objectives, scope of project and thesis outline. Chapter two will discuss on the literature review which related in study

background. In Chapter three, the discussion will be on the methodology in conducting this project which includes the methods and techniques used. In Chapter four, the results and the discussion will be discussed. Finally, conclusion and recommendation are presented in Chapter five. For the project to be successfully implemented, there are several areas to look in to. The following are the main chapters:

Chapter I is study the objectives and scope of work on the project. The aim of this project is to design and develop robot vacuum cleaner by using a Programmable Interface Controllers (PIC) microcontroller and develop an instruction of high level language using PIC compiler.

Chapter II is literature review in important components and relevant hardware. Research and read up relevant topics from sources such as reference book, internet and journal will enable to gain more understanding and information for project. Research on similar system in the market and knowing what are the features and capabilities of current products will also provide more information and understanding on the project.

Chapter III is Project methodology includes the planning, the development of the design and the management of the project. This chapter will explain more about the project methodology used in the project. This part will explain more about the project path from the beginning until it is completed. Every work flow that has been done in this project should be explained step by step.

Chapter IV is implementation, problems faced and the solution. The fourth chapter should focus on hardware and simulation of the design circuit. This chapter also shows about testing process. Testing will be performed on each individual module on both hardware and software of the system.

Chapter V is conclusions and recommendations on the project. The last chapter will review on the project, whether the implemented solution meet the objective of the project. Discussion on problems encountered, conclusions and suggestions will be included for the future improvements on this project.

CHAPTER II

LITERATURE REVIEW

This chapter present the literature review of mechanism of vacuum cleaner, system design, analysis and research has been done for preparation in term of selecting materials and understanding the PIC configurations in order to develop this project.

2.1 Introduction to The Principles of Vacuum Physics

The word “vacuum” actually comes from the Latin word which is “vacua” and it means “empty”. However, a totally empty space in nature does not exist, thus there is no “ideal vacuum”. Vacuum is only a partially empty space, where some of

the air and other gases have been removed from a gas containing volume (“gas” comes from the Greek word “chaos” = infinite, or as known as empty space). In other words, vacuum means any volume containing less gas particles, atoms and molecules (a lower particle density and gas pressure), than there are in the surrounding outside atmosphere. Accordingly, vacuum is the gaseous environment at pressures below atmosphere [3].

2.2 How Does Conventional Vacuum Cleaner Works

Basically Vacuum Cleaner works as suction method with a brush and suction head a front a motor in the middle. Based on the diagram, there are showing the process of vacuum cleaner. Electricity from socket will supplies energy to the cleaner’s electric motor. Basically in a conventional cleaner, the electric motor is rated at about 500 to 1000 watts [6] so it uses five to ten times as much energy as an old-style like incandescent lamp. Rubber belt (blue) powered by electric motor will turns brushes and beaters on the roller at the front of the machine. Vigorous beating and brushing loosens dirt from the carpet or rug. Fan attached to the electric motor sucks air and loosened dirt in through the front of the machine. Dirty air travels through to the back of the machine, thus it will cooling the electric motor as it passes by. Dirt is trapped in the bottom of the dirt bag (which may be a single fabric bag or a disposable paper bag fixed inside a fabric bag). Relatively clean air emerges out of the back. The outgoing air is much warmer than the incoming air because it's picked up waste heat from the electric motor [5].

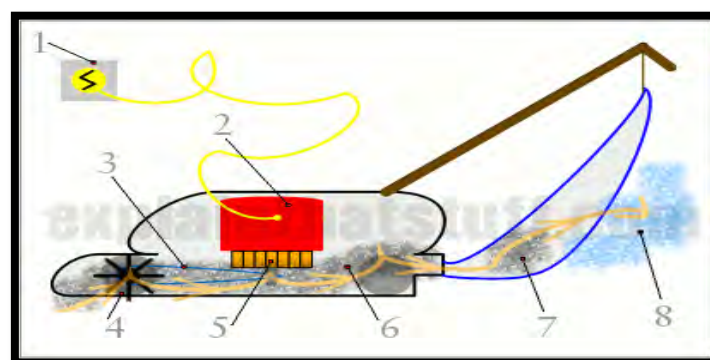

Figure 2.1: Conventional Vacuum Cleaner Works