

ARTIFICIAL IMMUNE ALGORITHM BASED GRAVIMETRIC FLUID DISPENSING MACHINE

David F. W. Yap*

Faculty of Electronics and Computer Engineering, Universiti Teknikal Malaysia Melaka (UTeM)
Hang Tuah Jaya, 76100 Durian Tunggal, Melaka, Malaysia.
david.yap@utem.edu.my
(Tel: +6013-6100182, Fax: 606-5558094)

S. P. Koh, S. K. Tiong, Edwin Y. S. Sim, M. W. Yaw
College of Engineering, Universiti Tenaga Nasional (UNITEN)
km 7, Kajang-Puchong Road, 43009 Kajang, Selangor Darul Ehsan, Malaysia.
johnnykoh@uniten.edu.my, siehkiong@uniten.edu.my,
edwin@uniten.edu.my, meiwyin@uniten.edu.my

Abstract— One of the most prominent methods used in handling the end process for materials-mixing is by having a dispensing system. An effective dispensing method using Pulse Width Modulation (PWM) at the end of the dispensing sequence with Artificial Immune System (AIS) automatic dispensing parameter fine tuning capability is proposed by optimizing the components of Dispensing Time and Stopping Time Delay to obtain constant and accurate reading from the precision balance scale. Based on the new dispensing sequence, experimental tests had been carried out using different materials with varying viscosities. The results denote that the combination of both PWM and AIS techniques would minimize the error rate for overshooting while exhibiting better accuracy. These are important in order to overcome the limitations of the conventional volumetric dispensing and manual parameter tuning presently applied in the dispensing system used in the coatings industry.

Keywords— Pulse Width Modulation, Gravimetric, Blending, Antibody, Affinity Maturation, Mutation.

I. INTRODUCTION

Manufacturers in the coating industry encounter difficulties in corrugated carton printing as the number of coatings used can be as high as 30 000. A solution to this problem called Blending was proposed and a typical range of 6 to 20 base ingredients can be blended to produce thousands of other types of coatings. In order to match the desired coatings, the printers must mix these base ingredients carefully and very accurately against a formula or mixing scheme from the coatings manufacturer.

The automatic fluid dispensing systems applied in the coatings industry are normally volumetric-based which operate by a measuring device (metering pump or other components) for each ingredient being dispensed. Volumetric system is susceptible to changes in temperature and air flow, which directly affect the end result in terms of accuracy, speed and quality.

In order to resolve this setback, a gravimetric [1][2] and Pulse Width Modulation (PWM) [3][4] based controlled fluid dispensing system with Artificial Immune System (AIS) dispensing parameter fine tuning capability is developed. The proposed dispensing system would weigh each required material accurately and at a higher speed. This closed loop control method provides dispense data which is very useful for

quality control, audit trail and quality-related problems diagnosis.

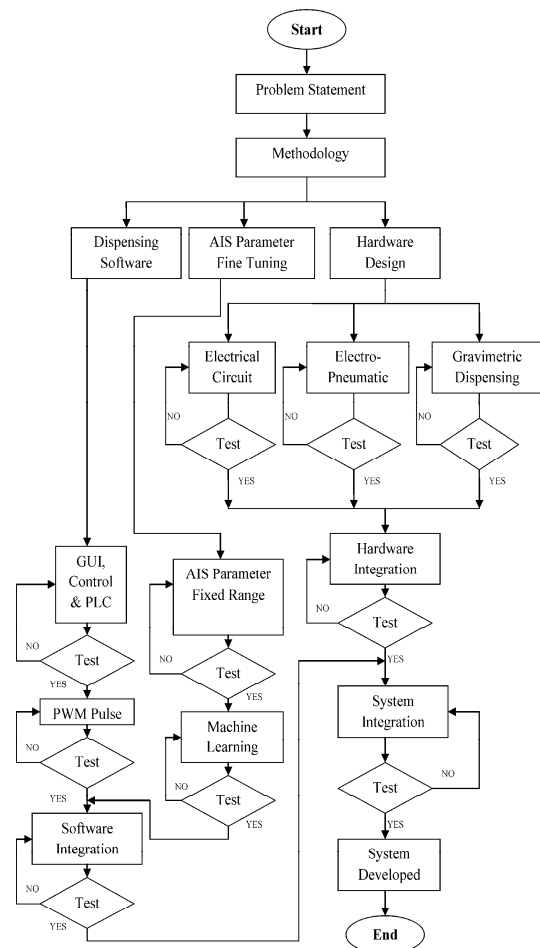

Fig. 1 Flow Chart of the Proposed System Development

The flow chart of the proposed fluid dispensing system is shown in Fig. 1. There are three major parts of the system. They are

- Dispensing software
- Hardware design of a single valve gravimetric fluid dispensing system
- AIS dispensing parameter fine tuning

II. DISPENSING SOFTWARE ARCHITECTURE

The dispensing software architecture consists of three major components shown in Fig. 2.

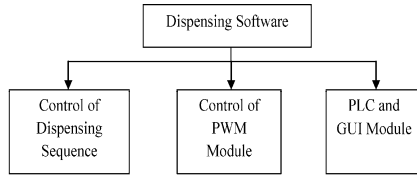

Fig. 2 Dispensing Software Architecture

A. Control of Dispensing Sequence

The dispensing parameters and the four major modes used are depicted in Table I.

TABLE I
DISPENSING PARAMETERS

Description	Symbol
Set Point for Big Flow to Small Flow	a
Set Point for Small Flow to PWM Pulse	b
Set Point for PWM Pulse to Spit Pulse	c
PWM Coefficient	d
Spit Coefficient	e

Computing the time profile of the dispensing flow is important to optimize the dispensing sequence. The total dispensing time (T_D) taken for the dispensing sequence as defined in Equation (1) is given by the summation of the process time (t_p), stable scale delay (t_{ssd}), and read delay (t_d).

$$T_D = \sum (t_p + t_{ssd} + t_d) \quad (1)$$

The aim of the system is to reduce the dispensing time given by the objective function in (2).

$$F = \min \sum T_D \quad (2)$$

B. Control of PWM Module

The parameters used in PWM Pulse technique are depicted in Table II.

TABLE II
PWM PULSE TECHNIQUE PARAMETERS

Description	Symbol
Stable Scale Delay	t_{ssd}
Read Delay	t_d
Accuracy Coefficient	ACC

The way of opening and closing of the dispense valve is an essential part of the PWM technique. First of all, a fast ejection of first pulse is needed to predict the subsequent pulses. Secondly, a t_{ssd} is required for the balancer to feedback on the weight of the first pulse. Once the first pulse has been dispensed, (3) would be applied on Subsequent PWM Pulse (SPP).

$$SPP = t_{ssd} + \frac{(\text{Target Weight} - \text{Achieved Weight}) * d}{\text{Weight for first PWM Pulse}} \quad (3)$$

SPP would evolve accordingly by means of adjusting the total dispensing time (T_D) to achieve c accurately in the shortest possible time.

Once c has been achieved, (4) would be used to calculate the Spit Pulse.

$$\text{Spit Pulse} = \frac{(\text{Target Weight} - \text{Achieved Weight}) * ACC}{e} \quad (4)$$

Spit Pulse would dispense according to ACC with t_d applied in between each pulse to achieve the final Target Weight.

The timing diagram depicting the PWM Pulse technique is illustrated in Fig. 3. The PWM pulse technique applied would optimize the accuracy factor.

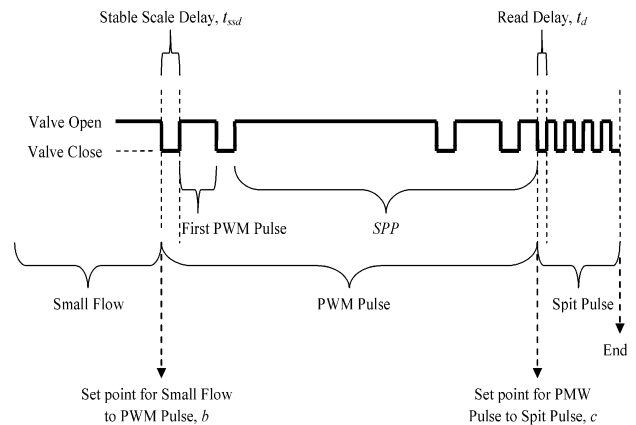

Fig. 3 Timing Diagram for PWM Pulse Technique

III. GRAVIMETRIC DISPENSING HARDWARE SETUP

The Gravimetric Dispensing System setup is illustrated in Fig. 4.

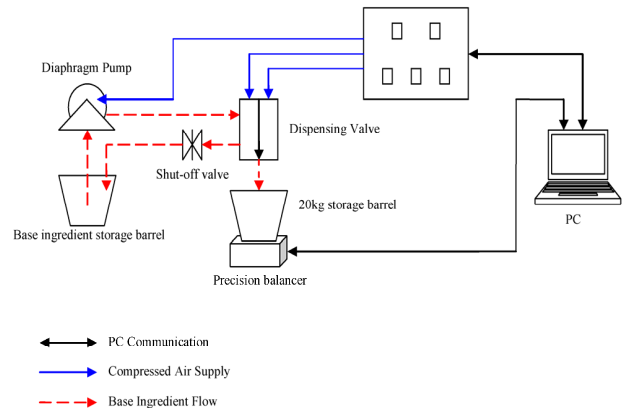

Fig. 4 Gravimetric Dispensing System Setup

IV. AIS DISPENSING PARAMETER FINE TUNING

A. Artificial Immune System – Clonal Selection for Optimization

Artificial Immune Systems (AIS) are inspired by theoretical immunology and observed immune functions, principles and models, which are applied to engineering problem solving [5]. The clonal selection algorithm is a branch of AIS with principles extracted from clonal expansion and affinity maturation [6]. The clonal selection theory explains that when an antigen (Ag) is detected, antibodies (Ab) that best recognize this Ag will proliferate by cloning. This immune response is specific to each Ag.

The immune cells will reproduce in tandem with a replicating Ag until it is successful in recognizing and fighting against this Ag. Some of the new cloned cells will be differentiated into plasma cells and memory cells. The plasma cells produce Ab and will undergo mutation that will promote their genetic variation. The memory cells are responsible for the immunologic response for future Ag invasion. Subsequently, the selection mechanism will keep the cells with the best affinity to the Ag in the next population. The process of a standard clonal selection algorithm can be characterized in pseudo-code format in Fig. 5. The summary of the clonal selection optimization is described in [7].

```

begin AIS
  c:=0 { counter }
  Initialize population
  Do:
    Compute affinity
    Generate clones
    Mutate clones
    Replace lowest affinity Ab with a new randomly generated Ab
  c:=c+1
  end
end AIS
  
```

Fig. 5 Pseudo-code of the Clonal Selection Algorithm

B. AIS Parameter Range Determination

The experiment was conducted using the AIS parameters as shown in Table III. Note that the required size of population is relatively small as each given Ab is set within a fixed range as depicted in Table IV. This would reduce the searching space, hence reducing the number of Abs and generations required for convergence. The flow chart of the AIS dispensing parameter fine tuning program is shown in Fig. 6.

TABLE III
AIS PARAMETERS

Parameters	Specification
Population Size	20
Clone Size Factor	2
Maturation Rate	0.40
Criteria Termination	30 Generations

TABLE IV

FINE TUNING RANGE DISPENSING PARAMETERS

Dispensing Parameters	Symbol	Max Range	Min Range
Set Point for Big Flow to Small Flow	<i>a</i>	300g	500g
Set Point for Small Flow to PWM Pulse	<i>b</i>	50g	300g
Set Point for PWM Pulse to Spit Pulse	<i>c</i>	10g	50g
PWM Coefficient	<i>d</i>	0	5
Spit Coefficient	<i>e</i>	1000	2000

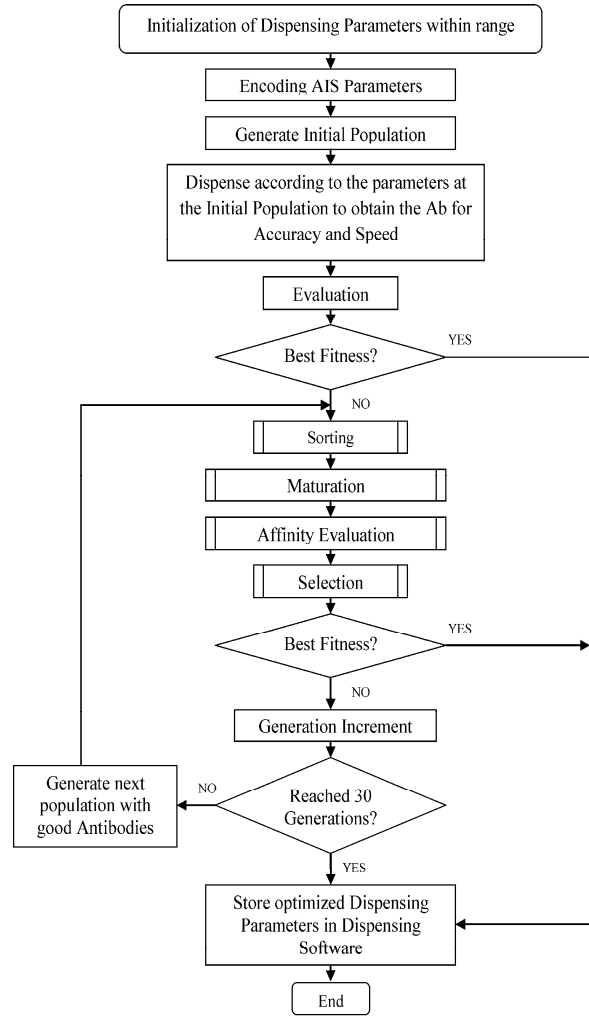

Fig. 6 Flow Chart of the AIS Dispensing Parameter Fine Tuning Program

C. Fitness Function

The overall fitness function (F) consists of the fitness of accuracy (F_e) and speed (F_s) obtained from online measurement of the precision balancer and dispensing time. The fitness function is defined by (5) to (8).

$$F = 1 / \{ \exp[u F_{es}] \} \quad (5)$$

Where

$$F_{es} = F_e * F_s \quad (6)$$

$$F_e = 1 / \{ 1 - \exp[w (\text{Accuracy})^x] \} \quad (7)$$

$$F_s = 1 / \{ 1 - \exp[y (\text{Speed})^z] \} \quad (8)$$

The exponential function is applied in the AIS optimization process to allow the overall fitness function (F) to gradually reach the peak. Coefficient u determines the sensitivity of the fitness function (F). In this application, coefficients w and x were set to -0.015 and 0.6 while coefficients y and z were set to -0.02 and 0.6 . These settings are to prioritize the accuracy over speed in the overall fitness function (F). To further fine-tune the overall exponential fitness, coefficients u and v are set to -0.3 and 0.45

V. EXPERIMENTAL RESULTS

Three different types of fluids with varying viscosity as depicted in Table V were applied into the dispensing sequence for characterization and to establish the reliability of the system.

TABLE V
VISCOSITY OF THE TESTED MATERIALS

Medium	Viscosity at room temperature (pascal-second)
A	8.94×10^{-4}
B	1.06×10^{-3}
C	0.81

First of all, the dispensing parameters described in Table I are fine-tuned using AIS to obtain the optimum dispensing parameters for all the mediums. The system is then dispensed according to the array of antibodies which represent the solutions to obtain the primary fitness function. Thereafter, the primary fitness function will undergo selection and affinity maturation to obtain the best fitness in terms of accuracy and speed.

Upon confirmation of the optimum dispensing parameters via AIS, the reproducibility and consistency of the dispensed weight after various dispensing events are evaluated by measuring the weight consecutively.

The steps for the accuracy and speed test with PWM are as follows.

- Step 1: Weight to Dispense: 5.2kg
- Step 2: Set Point for Big Flow to Small Flow: last 200g
- Step 3: Set Point for Small Flow to PWM Pulse: last 50g
- Step 4: Set Point for PWM Pulse to Spit Pulse: last 10g
- Step 5: PWM Coefficient: 1
- Step 6: Spit Coefficient: 2000

By applying the dispensing sequence using the optimum dispensing parameters (upon utilizing AIS dispensing parameter fine tuning), a consistent accuracy of $\pm 2g$ is achieved. Result of the reproducibility obtained for a 5.2 kg batch with comparison to random tuning is displayed in Fig. 7, Fig. 8 and Fig. 9.

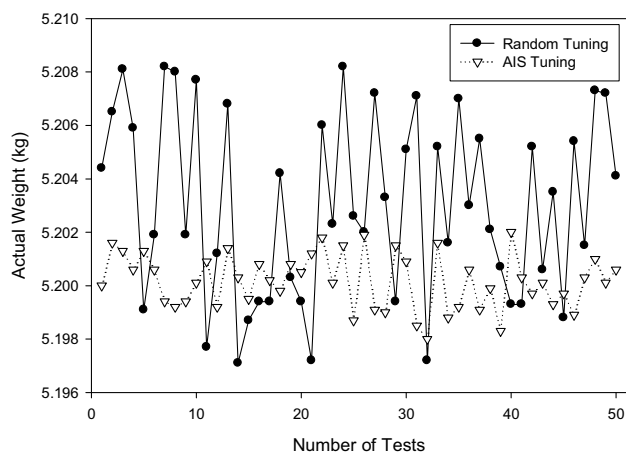

Fig. 7 Accuracy Test Using Optimum Dispensing Parameters for Medium A

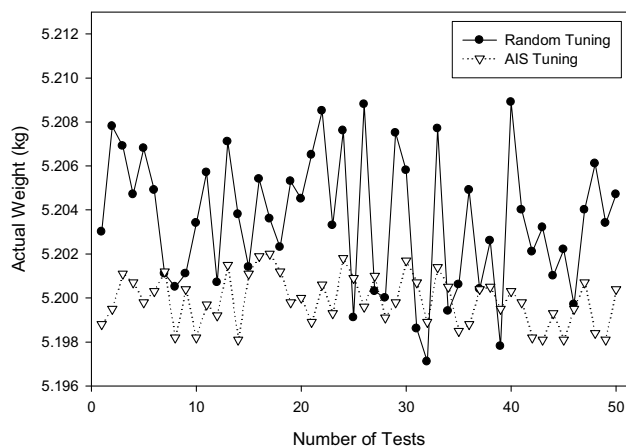

Fig. 8 Accuracy Test Using Optimum Dispensing Parameters for Medium B

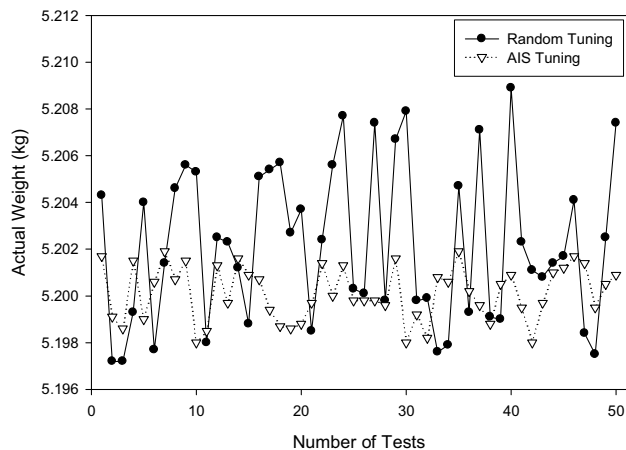

Fig. 9 Accuracy Test Using Optimum Dispensing Parameters for Medium C

VI. CONCLUSION

The introduction of an innovative fluid dispensing system with AIS dispensing parameter fine tuning has facilitated the user to automatically and optimally configure the dispensing parameters without going through the hassle of manual tuning. Good agreement has been found between the performance of the proposed dispensing technique and the experimental results. Furthermore, the implementation of AIS on the dispensing parameters fine tuning process optimizes the dispensing process for mediums with different viscosity as well as shortens the time scale for manual tuning. As far as accuracy is concerned, consistent and desired results have been achieved. Moreover, users without the technical knowledge of dispensing system can quickly adapt themselves into using the system knowing that the system itself has achieved optimum parameters that enable them to produce good result. In this way, it is possible for inexperienced and experienced users to achieve more dynamic operation of dispensing.

ACKNOWLEDGMENT

The authors would like to thank The Ministry of Higher Education Malaysia for the financial support under Fundamental Research Grant Scheme No. FRGS/2010/FKEKK/TK03/1 - F0085.

REFERENCES

- [1] R. Steger, P. Koltay, G. Birkle, T. Strobelt, H. Sandmaier, R. Zengerle, "Two-Dimensional Array of Piezostack Actuated Nanoliter Dispensers", Actuator 2002, 8th International Conference On New Actuators, Bremen, Germany, 2002.
- [2] W. Pöschel, R. Engel, "The Concept of a New Primary Standard for Liquid Flow Measurement at PTB Braunschweig", FLOMEKO '98, 9th International Conference on Flow Measurement, Lund, Sweden, 1998.
- [3] P. Bowler, "Pulse Width Modulation For Induction Motor Drives", Proceedings of the First IEEE International Caracas Conference on Devices, Circuits and Systems, Caracas, Venezuela, 1995.
- [4] I.G. Foulds, R.W. Johnstone, "A Pulse Width Modulation Controlled Bistable Micro Electro Mechanical System", CCECE05, 18th Canadian Conference on Electrical and Computer Engineering, Saskatchewan, Canada, 2005.
- [5] L. N. De Castro, and J. Timmis, Artificial Immune Systems: A Novel Paradigm to Pattern Recognition. Corchado, JM, Alonso, L and Fyfe, C (eds) Artificial Neural Networks in Pattern Recognition, SOCO-2002. University of Paisley, UK, 67-84.
- [6] L. N. De Castro, J. V. and Zuben, "Learning and Optimization using Clonal Selection Principle", IEEE Trans on Evolutionary Computation, Special Issue on Artificial Immune Systems, vol. 6, no. 3, pp. 239-251, 2002.
- [7] L. N. De Castro, and J. Timmis, Artificial Immune Systems: A New Computational Approach. New York: Springer-Verlag, 2002.