

Design of SIW Bandpass Filter with 6 dB Offset

Z. Zakaria¹, and B. H. Ahmad
 Faculty of Electronic & Computer Engineering
 Universiti Teknikal Malaysia Melaka
 Hang Tuah Jaya, 76100, Melaka, Malaysia
¹zahriladha@utem.edu.my

Abstract— This paper presents a novel design of SIW bandpass filter based on even- and odd-mode predistortion technique. This technique allows for the realization of lossy filter responses equivalent to lossless filter responses, although at an increased insertion and return loss. Hence, the filter can be designed with low Q_u resonators, which will significantly contribute to the reduction of its physical size and weight. An experimental third-degree filter with Chebyshev characteristic demonstrated good measured results, which were in-line with the simulated results.

Keywords- Bandpass filters; predistorted filters; SIW filters; lossy filters.

I. INTRODUCTION

Since the explosion of wireless communication systems, demand for further size and cost-reduction in microwave filter has increased. However, in general, the design of high-performance with highly selective filters requires high Q_u resonators, which contribute to significant physical size or expensive technologies. For instance, a dual mode waveguide filter [1] is bulky when used for satellite communication in space stations. Whilst dielectric resonator filters can offer high unloaded Q factors in reasonable physical size [2, 3], but they are expensive if low loss dielectric is required. Moreover, the superconducting filters offer very small physical size compared to dielectric resonator, but at the price of requiring the cooling systems [4].

Therefore, in order to overcome the aforementioned problems, it is preferable to design microwave filters in such a way to use low Q_u resonators and make them behave like high Q_u resonators. This can be achieved with passive loss compensation techniques with the aim of minimizing unloaded Q factor of the resonators, and consequently decreasing the size and expense of the filters.

There are several techniques of compensating losses such as reported in [5]-[9]. In this paper, a new class of SIW bandpass filter based upon a synthesis technique introduced in [10] is presented. It is shown in [10] that a symmetrical network can be formed directly from predistorted even- and odd-mode subnetworks, therefore eliminating the need for a hybrid 90° coupler. The advantages of this technique are the realizations of lossy filter responses are equivalent to an ideal lossless filters that are offset by a constant amount and would not require external devices.

The technique of predistorted even- and odd-mode has been well explained in [10],[11]. Fig.1 (a) shows a 3rd-order Chebyshev lowpass prototype in the form of simplified network. Its response is shown in Fig.1(b). The lowpass prototype contains two high- Q_u factor resonators ($Q_u = 5.39$) and one low- Q_u factor resonator ($Q_u = 2.558$). The dark circles represent 1 Farad capacitors with a given loss factor. Admittance inverters are represented by connecting lines and shaded circles represent nodes.

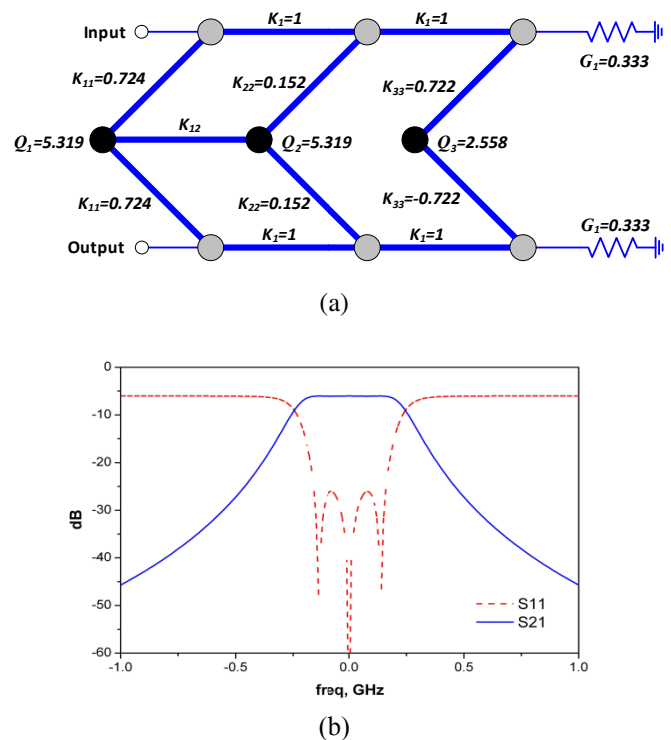

Fig. 1. Ideal 3rd-order Chebyshev lowpass prototype (a) simplified circuit, and (b) ideal response with 6dB offset [10],[11].

II. PRACTICAL SIW FILTER DESIGN

In this section, a systematic filter development using the lowpass prototype (Fig. 1(a)) as a starting point will be demonstrated. For realization purposes, the lowpass prototype is transformed to a bandpass filter using standard transformation. The theory behind the transformation is well

The authors would like to thank the UTeM for sponsoring this work

explained in [12]. The focus here will be with the resonators as can be seen in Fig. 2 the transformation to bandpass filter from lowpass prototype.

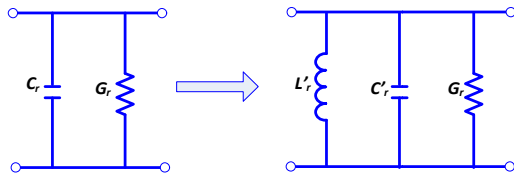

Fig. 2. Bandpass transformation of a capacitor with dissipative element.

Design example: Center frequency, f_o at 6.5 GHz with 125 MHz fractional bandwidth. The following equations for the bandpass transformation of a capacitor of the lowpass prototype (Fig. 2) are applied to obtain element values for element capacitors and inductors [12]:

$$C'_r = \frac{\alpha' C_r}{\omega_o} \quad (1)$$

$$L'_r = \frac{1}{\alpha' C_r \omega_o} \quad (2)$$

where α' is the bandwidth scaling factor,

$$\alpha' = \frac{\omega_o}{\omega_2 - \omega_1} \quad (3)$$

After scaling to 50 Ω the new element values for bandpass resonators are 2.5465×10^{-11} F and 2.3544×10^{-11} H respectively. The resistive element for the first and second resonator is 265.95 Ω and 127.90 Ω for the third resonator, respectively. The unloaded Q factor for this circuit is calculated using:

$$Q_u = \frac{\omega C}{G} \quad (4)$$

where

$$\omega = \frac{1}{\sqrt{LC}} \quad (5)$$

The bandpass filter now contains two high- Q_u resonators ($Q_u = 267.23$) and one low- Q_u resonator ($Q_u = 133.02$). Thus, the average Q_u factor is 238.26 and the filter is suitable to be realized in Substrate Integrated Waveguide (SIW) resonators [13]-[15]. The response of the 3rd-order Chebyshev bandpass filter is shown in Fig. 3 with passband insertion loss and return loss value of 6 dB and 26 dB respectively.

Further modifications on the circuit are needed for practical physical realization. For instance, the resistive loads on the ends of both main-lines are scaled to 50 Ω . Therefore, additional transmission lines are introduced in order to allow 50 Ω terminations for each main-line. Furthermore, the admittance inverters main-lines are replaced with $3\lambda/4$ microstrip lines in order to accommodate the separation between the SIW cavities. The final circuit is shown in Fig. 4.

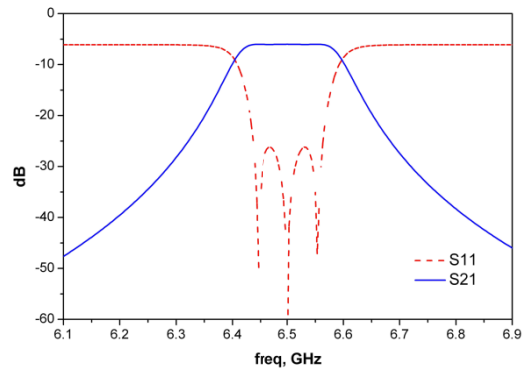

Fig. 3. Ideal response of 3rd-order bandpass filter with Chebyshev characteristic.

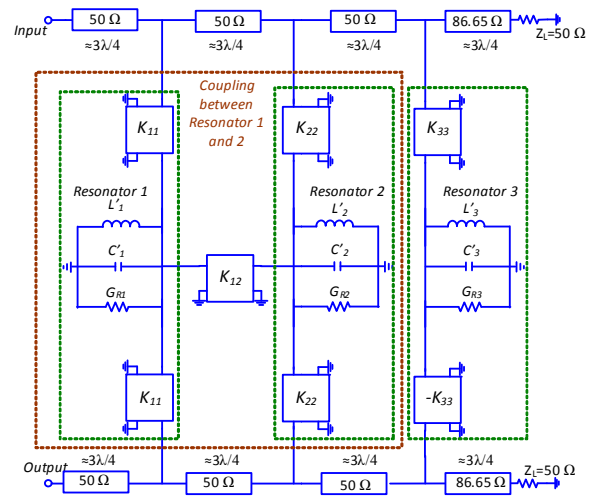

Fig. 4. Final circuit of bandpass filter.

The dimensions of rectangular waveguide for TE₁₀ mode operation with cut-off frequency of 4.301 GHz can be found using:

$$l = \frac{\lambda_g}{2} = \frac{\lambda_o}{2 \left[1 - \left(\frac{\omega_c}{\omega} \right)^2 \right]^{1/2}} = \frac{\lambda_o}{2 \left[1 - \left(\frac{\lambda_o}{2a} \right)^2 \right]^{1/2}} \quad (6)$$

The resonant frequency is determined using;

$$f_o = \frac{c}{\lambda_o} = \frac{c(a^2 + l^2)^{1/2}}{2al} \quad (7)$$

where l and a are the length and width of the rectangular waveguide.

The transformation to rectangular SIW is done simply by dividing the length, l , and width, a , of the rectangular waveguide with $\sqrt{\epsilon_r}$. The equivalent dimensions of the SIW cavity together via holes can be determined using a set of design rules explained in [16] and [17]. In this case, a diameter and distance of 0.8 mm and 1.6 mm is calculated, respectively. All

these dimensions can be further tuned and optimized during the simulation in order to obtain the desired responses.

The transition method from a rectangular SIW cavity to microstrip line is realized through coupling slot. In this case, the responses for each SIW resonator must be reasonably matched with the ideal responses exhibited from the ideal circuits. The coupling between first and second resonator is realized based on iris. They are connected through microstrip line in order to have a $3\lambda/4$ separation between the SIW resonator cavities. All the three SIW resonators can now be merged with microstrip main-line as bandpass filter; a combination of SIW and microstrip technology as shown in Fig. 5.

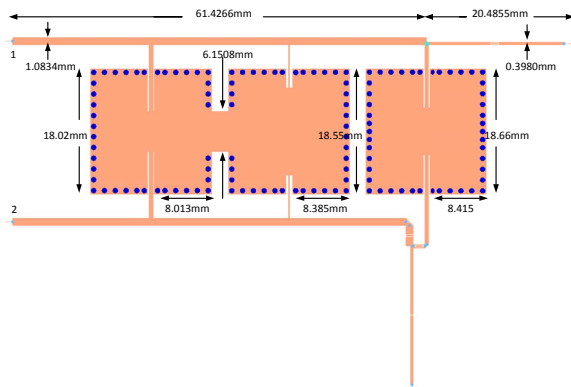

Fig. 5. Layout of SIW bandpass filter.

III. EXPERIMENTAL RESULTS

To verify the theory and simulation, the design is manufactured using a standard PCB process. The device is constructed using a 0.508 mm thick, Roger RO4350, dielectric substrate with permittivity constant $\epsilon_r = 3.48$. The copper thickness of copper is 35 μm and loss tangent is 0.0037.

The manufactured SIW bandpass filter, with overall length and width dimension of 81.94 mm x 61.40 mm, is shown in Fig. 6. The comparison between measured and simulated results is shown in Fig. 7. The measured results show the insertion loss (S_{21}) is approximately -7.09 dB and return loss (S_{11}) is better than -19 dB are obtained in the passband. However, there is a frequency shift of 68 MHz ($\approx 1.046\%$) from the desired centre frequency, which is due to the variations of permittivity in the substrate, i.e. 3.48 ± 0.05 and the inconsistencies of dielectric thickness, i.e. $0.508 \pm 0.0381\mu\text{m}$, and also manufacturing tolerance. The small amounts of losses in the passband are due to the losses of transition from microstrip to SIW, copper loss through conductivity, radiation loss through the surface of the SIW cavity, and losses through SMA connectors.

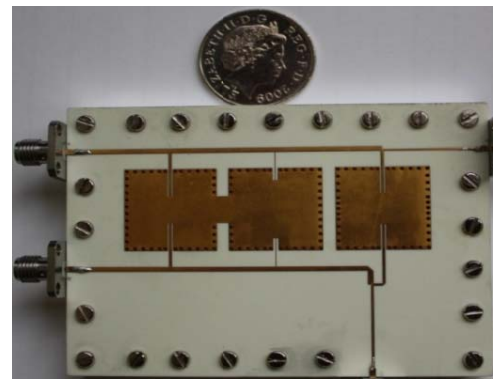

Fig. 6. Photograph of predistorted SIW bandpass filter.

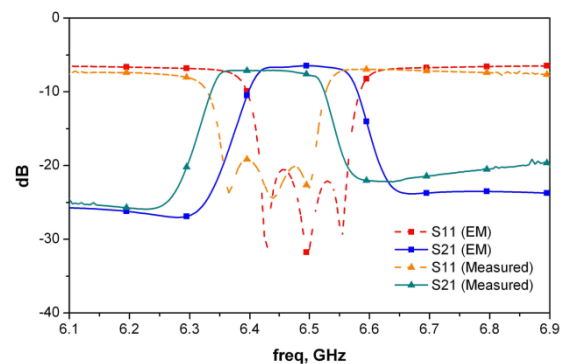

Fig. 7. SIW bandpass filter simulated and measured results.

IV. CONCLUSION

A new design of SIW bandpass filter based on predistortion technique has been successfully designed, manufactured and measured. The resulting lossy filter exhibit ideal lossless responses with an offset of approximately 6 dB. The filter is suitable for microwave systems where the increased insertion loss can be tolerated and size and weight reduction is very important such as in a satellite IMUX.

REFERENCES

- [1] C. Kudsia, R. Cameron, and W. C. Tang, "Innovations in microwave filters and multiplexing networks for communications satellite systems," *Microwave Theory and Techniques, IEEE Transactions on*, vol. 40, pp. 1133-1149, 1992.
- [2] I. C. Hunter, J. D. Rhodes, and V. Dassonville, "Dual-mode filters with conductor-loaded dielectric resonators," *Microwave Theory and Techniques, IEEE Transactions on*, vol. 47, pp. 2304-2311, 1999.
- [3] S. J. Fiedziuszko, I. C. Hunter, T. Itoh, Y. Kobayashi, T. Nishikawa, S. N. Stitzer, and K. Wakino, "Dielectric materials, devices, and circuits," *Microwave Theory and Techniques, IEEE Transactions on*, vol. 50, pp. 706-720, 2002.
- [4] R. R. Mansour, "Microwave Superconductivity," *IEEE Transactions on Microwave Theory and Techniques*, vol. 50, pp. 750-759, March 2002.

- [5] M. Dishal, "Design of Dissipative Band-Pass Filters Producing Desired Exact Amplitude-Frequency Characteristics," *Proceedings of the IRE*, vol. 37, pp. 1050-1069, 1949.
- [6] I. Hunter, A. Guyette, and R. D. Pollard, "Passive microwave receive filter networks using low-Q resonators," *Microwave Magazine, IEEE*, vol. 6, pp. 46-53, 2005.
- [7] A. C. Guyette, I. C. Hunter, and R. D. Pollard, "The Design of Microwave Bandpass Filters Using Resonators With Nonuniform "Q", *Microwave Theory and Techniques, IEEE Transactions on*, vol. 54, pp. 3914-3922, 2006.
- [8] W. M. Fathelbab, I. C. Hunter, and J. D. Rhodes, "Synthesis of lossy reflection-mode prototype networks with symmetrical and asymmetrical characteristics," *Microwaves, Antennas and Propagation, IEE Proceedings -*, vol. 146, pp. 97-104, 1999.
- [9] W. M. Fathelbab, I. C. Hunter, and J. D. Rhodes, "Synthesis of predistorted reflection-mode hybrid prototype networks with symmetrical and asymmetrical characteristics," *International Journal of Circuit Theory and Applications*, vol. 29, pp. 251-266, 2001.
- [10] A. C. Guyette, I. C. Hunter, and R. D. Pollard, "Exact synthesis of microwave filters with nonuniform dissipation," in *Microwave Symposium IEEE MTT-S International*, Hawaii, 2007, pp. 537-540.
- [11] A. C. Guyette, "Optimum Design of Microwave Filters with Finite Dissipation," in *School of Electronic and Electrical Engineering*. vol. Doctor of Philosophy UK: The University of Leeds, July 2006.
- [12] I. Hunter, *Theory and Design of Microwave Filters*. United Kingdom: The Institution Of Electrical Engineers, 2001.
- [13] B. B. Z. Sotoodeh, F. H. Kashani, H Ameri, "A novel bandpass waveguide filter structure on SIW technology," *Progress in Electromagnetics Research Letters*, vol. 2, p. 8, 2008.
- [14] C. Xiao-Ping, H. Liang, and W. Ke, "Synthesis and Design of Substrate Integrated Waveguide Filter Using Predistortion Technique," in *Microwave Conference, 2007. APMC 2007. Asia-Pacific*, 2007, pp. 1-4.
- [15] J. C. Bohorquez, B. Potelon, C. Person, E. Rius, C. Quendo, G. Tanne, and E. Fourn, "Reconfigurable Planar SIW Cavity Resonator and Filter," in *Microwave Symposium Digest, 2006. IEEE MTT-S International*, 2006, pp. 947-950.
- [16] D. Deslandes and K. Wu, "Design Consideration and Performance Analysis of Substrate Integrated Waveguide Components," in *European Microwave Conference, 2002. 32nd*, 2002, pp. 1-4.
- [17] D. Deslandes and W. Ke, "Single-substrate integration technique of planar circuits and waveguide filters," *Microwave Theory and Techniques, IEEE Transactions on*, vol. 51, pp. 593-596, 2003.