

Research Development of Energy Efficient Water Hydraulics Manipulator for Underwater Application

Ahmad AnasYusof^{1,a}, Faizil Wasbari^{1,b} and MohdQadafie Ibrahim^{2,c}

¹Faculty of Mechanical Engineering, Universiti Teknikal Malaysia Melaka, Malaysia

²Faculty of Engineering Technology, Universiti Teknikal Malaysia Melaka, Malaysia

^aanas@utem.edu.my, ^bfaizil@utem.edu.my, ^cqadafie@utem.edu.my

Keywords: Energy Efficiency, Water Hydraulics, Manipulator, ROV

Abstract. This paper presents research development of water hydraulics manipulator test rig for underwater application at Centre for Advanced Research on Energy, Faculty of Mechanical Engineering, Universiti Teknikal Malaysia Melaka. The test rig is designed in order to study the effectiveness of using water hydraulics system for underwater manipulation application. With objectives to promote sustainability and energy saving, the manipulator system is targeted for usage in an underwater scenario, possibly on small submarines or underwater remotely operated vehicles (ROVs). Underwater vehicles normally utilize the use of oil hydraulics for propulsion, manipulation and instrument control. The research on underwater manipulator that uses the surrounding sea water itself as the power and energy carrier for control is now possible with the current development in water hydraulics technology.

Introduction

A water hydraulics manipulator test rig for underwater application is being built at Universiti Teknikal Malaysia Melaka. One reason why the test rig is being developed in the first place is that in order to determine the drag, cavitations and the exerted pressure on the water hydraulics manipulator, a simulated underwater scenario is useful. Underwater manipulator's stability and control is very important in order to evaluate the performance of ROVs operation. Nowadays, ROVs are the dominating type of vehicles for underwater operations. It has been seen in action in the civilian, military and scientific sectors, most of them for deep underwater rescue operation, salvage operations, and sea-bed maintenance operation.

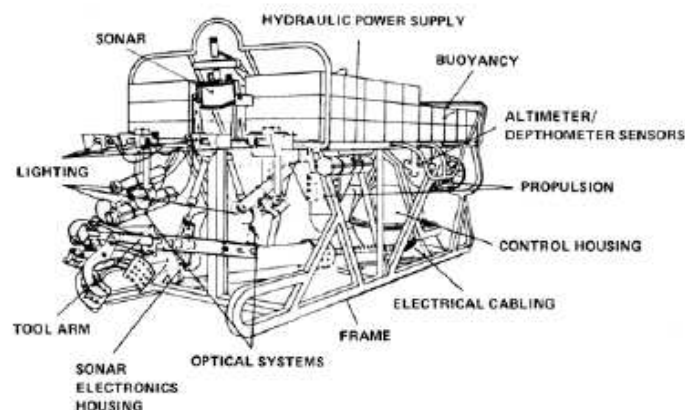

Fig.1: Cable controlled underwater recovery vehicle CURV [1]

ROVs have been used successfully in deep underwater rescue operation. For example, the use of CURV or Cable-controlled Underwater Recovery Vehicle in Fig. 1, had safely hauled up a crippled PISCES II submersible vehicle with two British crewmen on board, which had sunk 1600 feet to

Ireland sea floor while working on a transatlantic cable assembly in 1973[1]. In 2010, the recovery operation of Deep-water Horizon oil spill in the Gulf of Mexico also adopted the use of multiple ROVs to inspect and stop the leaks in the underwater oil rigs by capping the gushing wellhead, which was releasing about 4.9 million barrels (780,000 m³) of crude oil caused by an explosion on the well sites [2].

In this research, a scenario which involves the application of ROVs' underwater water hydraulics manipulator will be simulated by using the test rig. The manipulator will be controlled by using four linear actuators. Water, as the power medium is chosen to drive the actuators, since water is fireproof, environmental-friendly and generally a non-contaminant element [3-5]. The use of water hydraulics is increasing in the area of food processing, such as in cheese making and abattoirs, in hazardous condition involving fire-fighting, and in other areas such as oil recovery and sewerage service [6]. The challenges in using water as the pressurized medium come with the low viscosity properties that the water offers, which promotes higher chances of leakages, relative to traditional use of mineral oil [7]. It is also reported that water hydraulics is only recommended for application with supply pressure up to 160 bars [8]. However, the use of customized cylinders, in a pressurized underwater environment may satisfy the necessary requirements to solve the problem of leakages in water hydraulics components. Furthermore, driving an underwater manipulator with the same surrounding water could result in a multi-purpose device suitable for an environmental friendly approach in underwater robotics [9]. The manipulator arm of this project is representing the jointed arm configuration also known as articulate arm which connected via a twisting joint.

The Development of the Test Rig

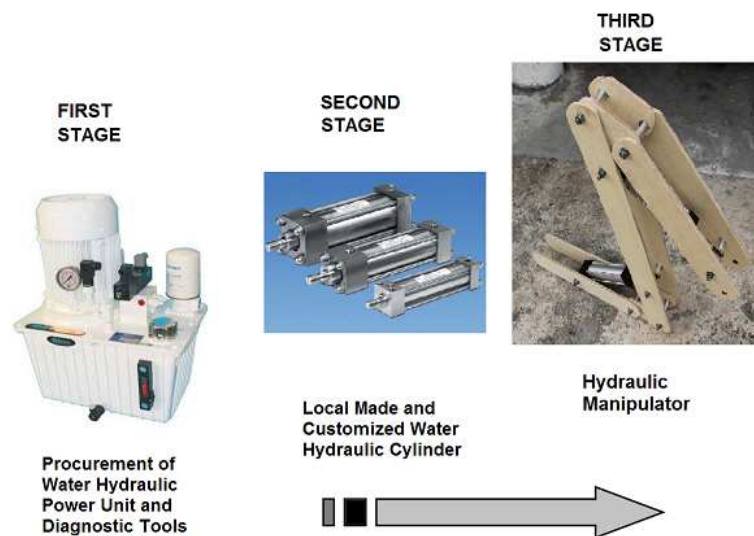

Fig. 2: Water Hydraulics Test Rig Development Stages

The development of the test rig comes with three stages, as shown in Fig. 2. The first stage of the project is the development of a water hydraulics power unit. Investigation on the performance and volumetric efficiency of the water hydraulics pumps throughout the development of the power unit will be conducted. The second stage focuses on the design and fabrication process of local made water hydraulics cylinders. This stage will also comprise validation and retrieval of actual wear condition and particles of water hydraulics components and its influence on the system's hygienic. The third stage of the research concentrates on the integration of a water hydraulics system for underwater manipulator test rig fabrication. The test rig will simulate the underwater scenario, whereby the stability, efficiency, and the performance of the manipulator will be tested.

Test Rig Setup. The power unit, as shown in Fig. 3, is fitted with an external gear pump, coupled with a single phase 1 hp inverter-controlled electric motor. Data logging on the power unit is made available with the use of a multi-hand data logger, a pressure transducer, temperature sensor and

gear type flow meter. All the diagnostic tools will be used to data-log flow, pressure, temperature and speed of the system. The available working pressure, flow and the efficiency of the pump with respect to loading condition will be studied by using this equipment.

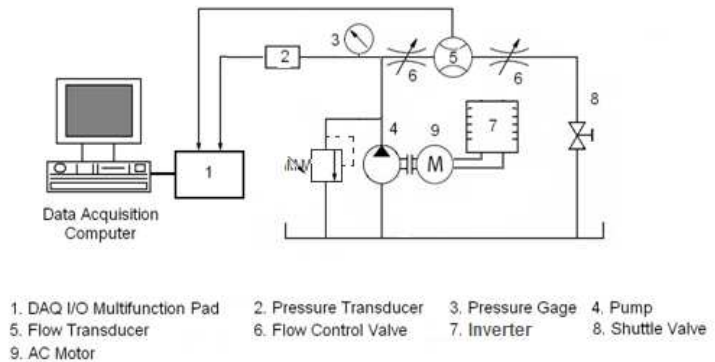

Fig. 3: Water Hydraulics Pump Test-Rig and Schematics

Pump Performance Analysis. A performance analysis has been conducted on the water hydraulics pump, with simulation during 30 and 260 bar. The results, as shown in Fig. 4 and Fig. 5, suggest that the use of water is possible, if the slip flow coefficient SF is maintained to 0.005. The flow rate varies from rotational speed of 250 to 3500 RPM, and provide volumetric efficiency ranges from 9% to 97% accordingly. The results conclude that water can be applied in typical oil hydraulics gear pump. This is true if the SF can be achieved with an acceptable value. This is supported by previous experiment results, whereby a gear pump was used in lifting an industrial scissor lift, by using reverse osmosis water, instead of oil, as the power medium. It was noted that the equipment managed to lift up to 400 kg of load, with workable water temperature of $41.4^{\circ}C$ [10].

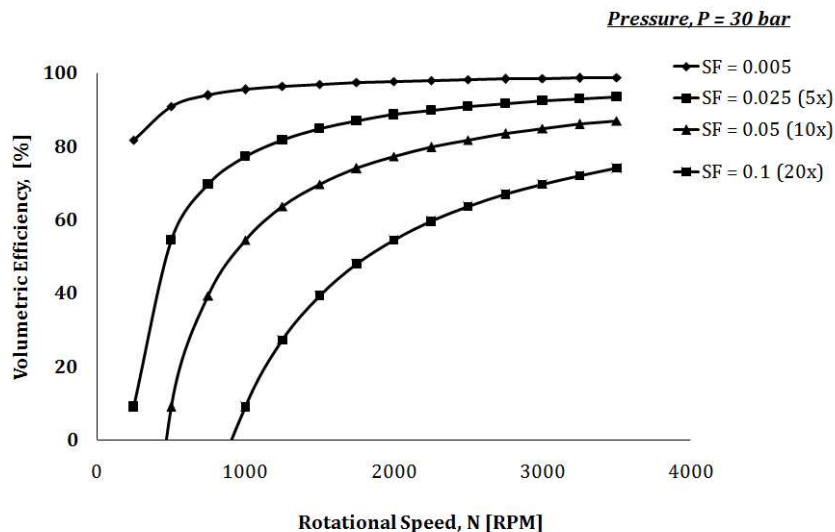

Fig.4: Simulation of Gear Pump for Slip Flow Coefficient at 30 bar

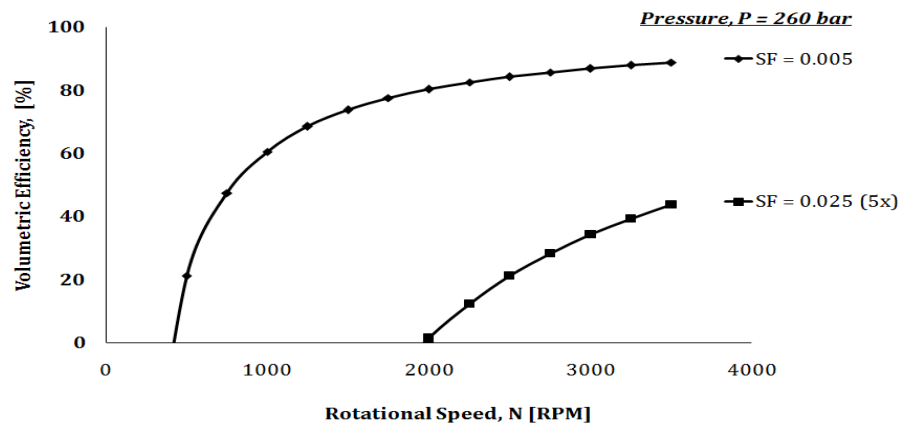

Fig. 5: Simulation of Gear Pump for Slip Flow Coefficient at 260 bar

Fabrication of Custom-Built Cylinder. A custom-build water hydraulics cylinder is being developed as the actuator for water hydraulics manipulator. The cylinder has double acting configuration, with bore size and stroke of 40 cm and 125 cm respectively. Tie-rod design is used in the research, since the cylinder can be reassembled for maintenance and evaluation study on corrosion and wear. In the design and development process, the suitability of water with each and every component inside the cylinder is very important. The components such as the cylinder block, cylinder barrel, various seals, piston, rod, wiper, tie rod, and adjustable screw and nuts.

Fitness Test. A fitness test has been conducted on the custom-built cylinder, which is done in order to evaluate cylinder's strength and leaks, as shown in Fig. 6. The test involves filling the cylinder with hydraulics oil, which also aid the lubrication process of the cylinder. Maximum pressure is set at 60 bar. The cylinder is let to extend until the maximum. The full extension of the cylinder create a pressure built-up inside the chamber. During the experiment, a loud bang can be clearly heard after that. A bursting leak can also be visually detected afterwards. The cylinder burst in between the barrel and cylinder cap end, as shown in Fig. 7. The recorded pressure at the time of the leak is around 50 bar. An investigation after the test reveals that the surface of the barrel did not fit perfectly into the cap end fixture. This is caused by imperfect cutting process of the barrel. At the same time, it is noted that the seal at the cap end and rod end of the cylinder is also broken, due to high pressure effect.



Fig.6: The fitness test



Fig.7: Leak point during the bursting leak

Manipulator Design. The manipulator is made up of a series of segments and joints that connect four segments together and allow them to move relative to one another. The joints provide either linear (straight line) or rotary (circular) movement. The manipulator is designed with four joints,

each driven by a water hydraulics linear actuator. Each actuator or cylinder has double acting configuration, and is able to sustain a maximum extension of 125 cm, with bore size of 40 cm, as shown in Fig.8. The manipulator has four electro-valves to control the movement of the cylinders. This allows the human operator to manipulate the actuator by changing the switching position of the valves.

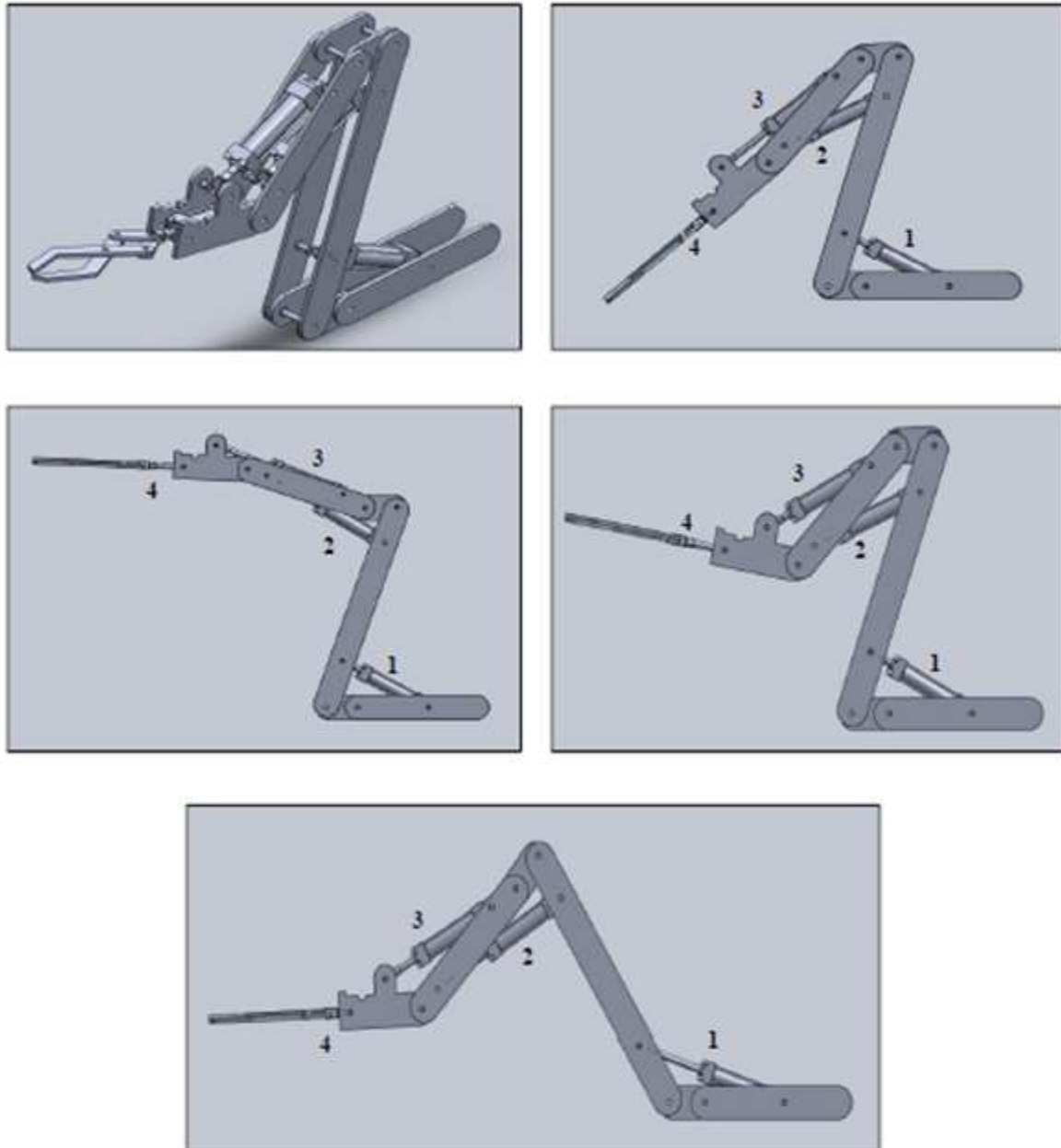

Fig.8: The design of the manipulator

Conclusion

An underwater manipulator test rig is being developed at the Centre for Advanced Research on Energy, Faculty of Mechanical Engineering, Universiti Teknikal Malaysia Melaka, in order to explore the possibility of using water hydraulics as an alternative sustainable application, as well as in promoting energy efficiency. By using the surrounding water itself in driving the manipulator, it is hoped that water hydraulics could help in reducing the problem regarding the energy loss in traditional hydraulics power system. Analysis of pump performance during simulated 30 and 260 bar loading pressure suggests that the use of water in the modified pump is possible, if the slip flow coefficient is maintained at 0.005. The flow rate varies from rotational speed of 250 to 3500 RPM,

and provide volumetric efficiency ranges from 9% to 97% accordingly. Fitting test on a custom-built cylinder has shown that non-corrosive polyvinyl cylinder can withstand maximum pressure up to 50 bar. However, the respective leak is much associated with the workmanship during the fabrication of the cylinder. At the same time, a manipulator has been designed with four joints, each driven by a water hydraulics linear actuator, in order to analyze the effectiveness of the system for underwater application.

Acknowledgement

The research work is supported under the short term project PJP/2012/FKM(15A)/S01090. The authors wish to thank Universiti Teknikal Malaysia Melaka for their financial support.

References

- [1] Salvops 73. Report, Department of the Navy Naval Sea Systems Command. (1977).
- [2] Examination of Deepwater Horizon Blowout Preventer, Final Report, United States Department of the Interior, EP030842. (2011).
- [3] E.Trostmann, B.Frolund, B.H. Olesen and B.Hilbrecht, Tap Water as a Hydraulic Pressure Medium, Marcel Dekker, Inc.(2001).
- [4] W.Backe, Water or oil Hydraulics in the Future, The Sixth Scandinavian International Conference on Fluid Power, SICFP'99, Tampere, Finland, pp. 51 – 65.(1999).
- [5] B.Hilbrecht, Water as a pressure Medium in Water Hydraulics, Proceedings of the 48th National Conference on Fluid Power (NCFP'2000) Chicago, Illinois, USA, pp. 555 – 559.(2000).
- [6] M.Higgins, Water hydraulics – the real world, Industrial Robot: An International Journal. 23:4 (1996)13–18.
- [7] G.H.Lim, P.S.K.Chua, and Y.B.He, Modern water hydraulics- the new energy transmission technology in fluid power. Applied Energy. 76 (2003)239 – 246.
- [8] F.Conrad, Trends in design of Water Hydraulics - Motion Control and Open-ended Solutions, Proceedings of the 6th JFPS International Symposium on Fluid Power, Tsukuba, Japan, pp. 420 – 430.(2005).
- [9] H.Yoshinada, T.Yamazaki, T.Suwa, T. Naruse and H. Ueda. Seawater hydraulic actuator system for underwater manipulator, Proceeding of the 5th International Conference on Advanced Robotics, Pisa, Italy, pp. 1330 – 1335.(1991).
- [10] A.A.Yusof, S.Mat and A.TDin. Promoting sustainability through water hydraulics technology: The effect of water hydraulics in industrial scissor lift. Applied Mechanics and Materials. 315(2013)488 – 492.

Advances in Manufacturing and Mechanical Engineering

10.4028/www.scientific.net/AMM.393

Research Development of Energy Efficient Water Hydraulics Manipulator for Underwater Application

10.4028/www.scientific.net/AMM.393.723