

Estimation of Real Power Transfer Allocation Using Intelligent Systems

H. Shareef, A. Mohamed, S. A. Khalid, and Aziah Khamis

Abstract—This paper presents application artificial intelligent (AI) techniques, namely artificial neural network (ANN), adaptive neuro fuzzy interface system (ANFIS), to estimate the real power transfer between generators and loads. Since these AI techniques adopt supervised learning, it first uses modified nodal equation method (MNE) to determine real power contribution from each generator to loads. Then the results of MNE method and load flow information are utilized to estimate the power transfer using AI techniques. The 25-bus equivalent system of south Malaysia is utilized as a test system to illustrate the effectiveness of both AI methods compared to that of the MNE method. The mean squared error of the estimate of ANN and ANFIS power transfer allocation methods are $1.19E-05$ and $2.97E-05$, respectively. Furthermore, when compared to MNE method, ANN and ANFIS methods computes generator contribution to loads within 20.99 and 39.37msec respectively whereas the MNE method took 360msec for the calculation of same real power transfer allocation.

Keywords—Artificial intelligence, Power tracing, Artificial neural network, ANFIS, Power system deregulation.

I. INTRODUCTION

THE introduction of electricity privatization becomes an important issue under electric industry restructuring. In open access environment, implementing transparent rules that allocate transmission use fulfill the concept of fairness in the industry. Fairness can only be achieved by adopting a fair and transparent usage allocation methodology acceptable to all parties. In view of market operation, it is vital to know the role of individual generators and loads to transmission wires and power transfer between individual generators to loads. This is necessary for the restructured power system to operate economically, efficiently and ensure open access to all system users [1]. Several schemes have been developed to solve the allocation problem in the last few years. Methods based on the Y-bus or Z-bus system matrices have recently received great

attention since these methods can integrate the network characteristics and circuit theories into line usage and loss allocation. The method reported in [2] was based on Kirchhoff's current law (KCL), equivalent linear circuit that reaches all lines and loads. Based on the stated assumptions, a recursive procedure was used to construct the equivalent circuit for each bus. Another circuit concept method was proposed by Chang and Lu [3]. It was based on the system Y-bus matrix and Z-bus modification. Starting from the load flow solution, branch current are determined as a function of generators' injected current. Similarly, contribution to bus voltages was computed as a function of each generator current injection by decomposing the network into different networks. Then by using approximate formulation it calculates the unbundled loss components. Teng [4], proposed a systematic method, very similar to that presented in [3], to allocate the power flow and loss for deregulated transmission systems. Using similar concept, the authors of this paper introduce a modified nodal equation (MNE) method for real and reactive power allocation [5], [6] in which the load buses powers are represented as a function of the generators' current and voltage.

The tracing methods [1], [7]-[10] based on the actual power flows in the network and the proportional sharing principles were effectively used in transmission usage allocation. The methods reported in [1] are based on tracing the current and complex power from individual power sources to system loads. Based on solved load flow, the method converts power injections and line flows into real and imaginary current injections and current flows. This method has a clear physical meaning. Bialek [7] proposed a novel power tracing method. However this method requires inverting a large matrix. F.F Wu et al. [8] proposed a graph theory to calculate the contribution factor of individual generators to line flows and loads and the extraction factor of individual loads from line flows and generators, which is theoretically efficient. This method cannot handle loop flows and losses must be removed initially. Reference [10] was based on the concept of generator 'domains', 'common' and 'links'. The disadvantage of this method is that the share of each generator in each 'common' is assumed to be same. Furthermore, the 'commons' concept can lead to problems since the topology of a 'common' could radically change even in the case of slight change in power flows.

Since the meshed and nonlinear nature of power system, the applications of Artificial Intelligence (AI) to power system

H. Shareef is with the Department of Electrical, Electronic & Systems Engineering, Universiti Kebangsaan Malaysia (UKM), 43600 Bangi, Selangor, Malaysia (phone: +603-89216590; e-mail: shareef@eng.ukm.my).

A. Mohamed is with the Department of Electrical, Electronic & Systems Engineering, Universiti Kebangsaan Malaysia (UKM), 43600 Bangi, Selangor, Malaysia (phone: +603-89216323; e-mail: azah@eng.ukm.my).

S. A. Khalid is with Faculty of Electrical Engineering, Universiti Teknologi Malaysia (UTM), 81310 Skudai Johor, Malaysia (e-mail: nizam@fke.utm.my).

Aziah Khamis is with the Department of Electrical, Electronic & Systems Engineering, Universiti Kebangsaan Malaysia (UKM), 43600 Bangi, Selangor, Malaysia, on leave from Department of industrial power, Universiti Teknikal Malaysia Melaka (UTeM), Hang Tuah Jaya, 76109 Durian Tunggal, Melaka, Malaysia. (phone: +603-89216590; e-mail: aziah@utem.edu.my).

become a great potential to explore, especially in power tracing problem. Mustafa et al. [11] incorporated an Artificial Neural Network (ANN) to reactive power allocation in deregulated power system. It uses modified nodal equation [5] results to train ANN. Similarly, research has been carried out by applying feed forward ANN for energy loss problem [12]. This method is relatively simple, and easy to apply for loss allocation problem. Optimization technique also has been explored in solving the power allocation problem [13]. The authors proposed a tracing compliant that minimizes overall deviation from the postage stamp allocation. Nevertheless, the approach treats the power tracing problem as a linear constraint optimization problem. In a related work, a continuous genetic algorithm (GA) for real power tracing has been proposed in [14]. The problems of this technique are that it produces multi solution results and requires long time for computation.

Basically, support vector machine (SVM) is designed to solve the classification problem [15]. Then, it is extended for the case of nonlinear function estimation. Reference [16] uses SVM for detection of abnormalities and electricity theft by incorporating the genetic algorithm to SVM. Using similar concept, the authors of this paper also adopts the hybridization of GA and least square SVM (LS-SVM) into reactive power tracing problem [17]. The new reactive power tracing method is based on manipulation of proportional sharing method [7] and application of GA to tune the performance parameters of LS-SVM.

To overcome the parameter selection problems in LS-SVM method, other AI techniques such as adaptive neuro-fuzzy interface system (ANFIS) can be used. For example, adaptive neuro-fuzzy inference system (ANFIS) approach was used to define fault location in a transmission line. Wavelet signal with and without power swing were trained to predict km distance from feeding substation [18]. Same ANFIS approach with series-parallel design was used in [19] to predict the power transfer allocation from generators to load. The designed method relies on the trained ANFIS blocks for the simulated distribution network. ANFIS with enhanced feature extraction technique was found to be superior compared to SVM method [19]. However, this method requires considerable training time and additional feature reduction methods such as principle component analysis.

Therefore in order to avoid feature reduction and obtain fast and accurate results, a statistical method known as multivariable regression (MVR) approach is proposed in [20] for power tracing. The proposed method considers almost all system variables obtained from load flow solutions as dependent variables. The independent variables of the MVR model correspond to the real power transfer allocation results obtained from MNE method. Other several possible applications of regression analysis include prediction of future observations, assessment of the effect of relationship and general description of data structure [21]-[22].

This research deals mainly with investigation of ANN and

ANFIS power transfer allocation methods and identify most appropriate AI technique that can be used in power tracing by critically comparing the qualitative and quantitative performance of various methods. The rest of the paper is organized as follows. First, a brief review of modified nodal equation (MNE) method which was used as a teacher in training all AI methods is presented in Section II. Then the concepts of ANN and ANFIS method are highlighted in Section III. The modeling and the structure of each AI power transfer allocation method are illustrated in Section IV. Results and evaluation of computer simulation studies is illustrated in Section VII. Finally, conclusions are given in Section VIII.

II. MODIFIED NODAL EQUATIONS METHOD

The derivation, to decompose the load real powers into components contributed by specific generators starts with basic equations of load flow. Applying Kirchhoff's law to each node of the power network leads to the equations, which can be written in a matrix form as in (1) [5]:

$$I = YV \quad (1)$$

where V is a vector of all node voltages in the system, I is a vector of all node currents in the system, Y is the Y-bus admittance matrix.

The nodal admittance matrix of the typical power system is large and sparse, therefore it can be partitioned in a systematic way. Considering a system in which there are G generator nodes that participate in selling power and remaining L= n-G nodes as loads, then it is possible to re-write (1) into its matrix form as shown in (2):

$$\begin{bmatrix} I_G \\ I_L \end{bmatrix} = \begin{bmatrix} Y_{GG} & Y_{GL} \\ Y_{LG} & Y_{LL} \end{bmatrix} \begin{bmatrix} V_G \\ V_L \end{bmatrix} \quad (2)$$

Solving (2) for I_L , the load currents can be presented as a function of generators' current and load voltages as shown in (3):

$$I_L = Y_{LG} Y_{GG}^{-1} I_G + (Y_{LL} - Y_{LG} Y_{GG}^{-1} Y_{GL}) V_L \quad (3)$$

Then, the total real power P_L of all loads can be expressed as shown in (4):

$$P_L = \text{Re}(V_L I_L^*) \quad (4)$$

where (*) means conjugate,

Substituting (3) into (4) and solving for P_L the relationship as shown in (5) can be found;

$$P_L = \text{Re} \left\{ V_L \sum_{i=1}^{nG} \Delta I_L^* I_G + V_L \left((Y_{LL} - Y_{LG} Y_{GG}^{-1} Y_{GL}) V_L \right)^* \right\} \quad (5)$$

where

$$(Y_{LG}Y_{GG}^{-1})^* I_G^* = \sum_{i=1}^{nG} \Delta I_L^* I_G^*$$

nG: number of generators

A possible way to deduce load node voltages as a function of generator bus voltages is to apply superposition theorem and replace all load bus current injections into equivalent admittances in the circuit. After adding these equivalences to the diagonal entries of Y-bus matrix, (1) can be rewritten as in (6):

$$V = Y^{-1} I_G \tag{6}$$

where Y' is the modified Yof (1).

Next, adopting (6) and taking into account each generator one by one, the load bus voltages contributed by all generators can be expressed as in (7):

$$V_L = \sum_{i=1}^{nG} \Delta V_L^* I_G^* \tag{7}$$

It is now, simple mathematical manipulation to obtain the required relationship as a function of generators dependent terms. By substituting (7) into (5), the decomposed load real powers can be expressed as depicted in (8):

$$P_L = \text{Re}\{V_L \sum_{i=1}^{nG} \Delta I_L^* I_G^* + \sum_{i=1}^{nG} \Delta V_L^* I_G^* ((Y_{LL} - Y_{LG} Y_{GG}^{-1} Y_{GL}) V_L)^*\} \tag{8}$$

This equation shows that the real power of each load bus consists of two terms by individual generators. The first term relates directly to the generators' current and the second term corresponds to their contribution to the load voltages. This allocation method has clear physical meaning as it take into account the interaction between real and reactive power flows. Vector P_L is used as a teacher in all the AI methods in this paper. A more detailed derivation of MNE method is given in [5], [6].

III. INTELLIGENT METHODS USED FOR REAL POWER ALLOCATION

The following section describes an overview of the existing artificial intelligence power transfer allocation methods, namely ANN method [11] and the ANFIS method [19].

A. Function Estimation Using Radial Basis Function Artificial Neural Network (ANN)

The Radial basis function (RBF) ANN was first used to design artificial neural network by Broomhead and Lowe [23]. Radial basis function offer several advantages compared to multilayer perceptron (MLP) ANN. Firstly, they can be trained using fast two stages training algorithm without the need for time consuming non-linear optimization techniques. Secondly,

the RBFN possesses the property of best approximation [24]. The network consists of three layers namely, an input layer, a hidden layer and an output layer. The output of the RBF ANN network simply sums the weighted basis function without using any activation function. Assuming a single neuron at the output layer, the output of the RBF network is calculated using (9),

$$\eta(x, w) = \sum_{k=1}^S w_{1k} \phi_k(\|x - C_k\|_2) \tag{9}$$

where $\|x - c_k\|_2$ denotes the Euclidean distance between the input vector x and the center c_k , $\phi_k(\cdot)$ is a basis function, w_{1k} are the weights in the output layer, S is the number of neurons (and centers) in the hidden layer

The output of the neuron in a hidden layer is a non-linear function of the distance. In this work, the functional form of Gaussian basis function is defined as in (10),

$$\phi_k(\|x - c_k\|_2) = e^{-\|x - c_k\|_2^2 / \beta^2} \tag{10}$$

Note that the Gaussian basis function is most commonly used where the parameter β control the width of the RBF ANN and is commonly referred to as the spread parameter. In practice, the value of β that is too big or too small will cause degradation in the performance of the RBFN. The centers c_k are defined points that are assumed to perform an adequate sampling of the input space. Common practice is to select a relatively large number of input vectors as the centers to ensure an adequate input space sampling. RBF ANN performs two major functions which are training and testing. Testing is an integral part of the training process since a desired response to the network must be compared to the actual output to create an error function.

B. Function Estimation Using Adaptive Neuro-Fuzzy Inference System (ANFIS)

Adaptive Neuro-Fuzzy Inference System (ANFIS) is developed from Sugeno-type fuzzy inference system (FIS) for effective data processing. The development is a simple data learning technique by using configuration of neuro-fuzzy model with hybrid learning rule. FIS processes a given input mapping to get a target output. The ANFIS defines five layers which perform the function of fuzzification of the input values, aggregation of membership degree, evaluation of the bases, normalization of the aggregated membership degree and evaluation of function output values [25], [26].

The first layer is the input layer which receives input data that are mapped into membership functions so as to determine the membership of a given input. In this fuzzification process the following equations are utilized.

$$X_i(x) = \frac{1}{\left[1 + \left(\frac{x - c_i}{a_i}\right)^2\right]^{b_i}} \quad i=1,2,3,\dots,n \quad (11)$$

$$Y_i(y) = \frac{1}{\left[1 + \left(\frac{y - c_i}{a_i}\right)^2\right]^{b_i}} \quad i=1,2,3,\dots,n \quad (12)$$

where, X_i and Y_i are fuzzified input values, whereas a_i , b_i and c_i are the parameter sets from the Gaussian input membership function.

The second layer of neurons represents association between input and output, by means of fuzzy rules. Application of fuzzy operators involves the use of the product (AND) to the fuzzified input. Equation (13) represents the fuzzy relations obtained from the product fuzzy operators.

$$R_i = X_i(x) \times Y_i(y) \quad (13)$$

In the third layer, the output are normalized and then passed to the fourth layer. Here, the activation degree and normalization is implemented by using the following equation:

$$G_i = R_i / \sum_i R_i \quad (14)$$

Then the output data are mapped in the fourth layer to give output membership function based on the pre-determined fuzzy rules. Aggregation of all outputs are obtained by using (15) which is the product of the normalized activation degree and individual output membership function,

$$O_i = G_i (p_i x + q_i y + r_i) \quad i=1,2,3,\dots,n \quad (15)$$

where, p_i , q_i and r_i are the parameters from the output membership function,

Finally the outputs are summed up in the fifth layer to give a single valued output. The ANFIS has the constraint that it can only be designed as a single output system and the system must be of unity weights for each rule [27].

$$O = \sum_{i=1}^n O_i \quad (16)$$

IV. ANN MODEL FOR REAL POWER ALLOCATION

In this work, 1 RBF ANN with one hidden layer and one output layer has been chosen. The ANN power transfer allocation method is elaborated by designing an appropriate RBF ANN for the practical 25-bus equivalent power system of south Malaysia region as shown in Fig. 1. This system consists of 12 generators located at buses 14 to 25 respectively. They deliver power to 5 loads, through 37 lines located at buses 1,

2, 4, 5, and 6 respectively. The input samples for training is assembled using the daily load curve and performing load flow analysis for every hour of load demand. Similarly the target vector for the training is obtained from the MNE method. Input data (D) for developed ANN contains variables such as load bus voltage magnitude (V1, V2, V4 to V6), real power of loads (P1, P2, P4 to P6), reactive power of loads (Q1, Q2, Q4 to Q6), real power of generators (P14 to P25), reactive power of generators (Q14 to Q25) and line real power (Pline1 to Pline37) flows, and the target/output parameter (T) which is the real power transfer between generators and loads placed at buses 1, 2, 4 to 6. Hence the networks have 60 output neurons. Fig. 2 summarizes the description of inputs and outputs of the training and testing for ANN for real power allocation.

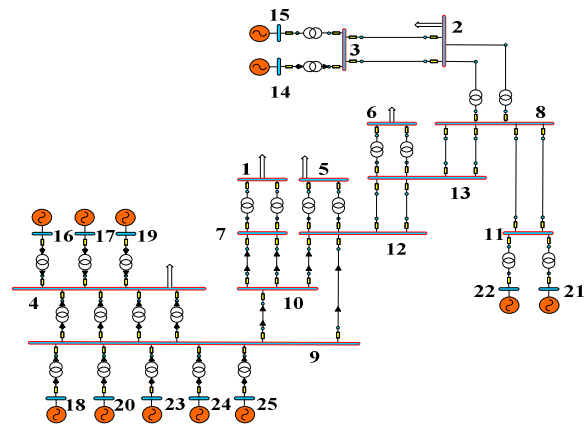

Fig. 1 Single line diagrams for the 25- bus equivalent practical power system

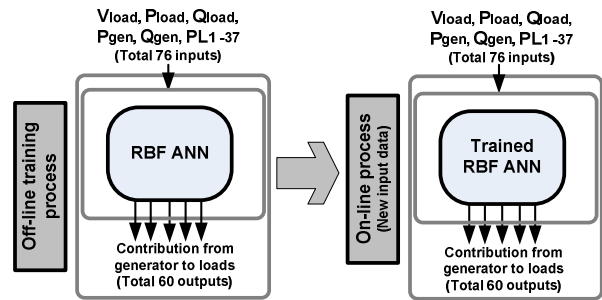

Fig. 2 Description of inputs and outputs of the training and simulation data for ANN real power allocation method

A. Training

After the input and target for training data is created, it can be made more efficient by scaling the network inputs and targets so that they always fall within a specified range. In this case the minimum and maximum value of input and output vectors is used to scale them in the range of -1 and +1. Next step is to divide the data (D and T) up into training. In this case 100 samples (60%) of data are used for the training.

The training of the RBF ANN consists of two separate stages. First step is to find the centers parameter by using the k-means clustering algorithm. After number of trials, k is taken

