

Modelling and Simulation of a Single Phase Grid Connected Using Photovoltaic and Battery Based Power Generation

Alias Khamis¹, Azah Mohamed², Hussain Shareef³, Afida Ayob⁴, Mohd Shahrieel Mohd Aras⁵

^{1,5}Department of Industrial Power, Faculty of Electrical Engineering,
Universiti Teknikal Malaysia, Melaka, Malaysia

^{2,3,4}Department of Electrical, Electronics and System Engineering
Faculty of Engineering and Built Environment
Universiti Kebangsaan Malaysia Bangi, Malaysia

¹alias@utem.edu.my, ²azah@eng.ukm.my, ³shareef@eng.ukm.my, ⁴afida@eng.ukm.my ⁵shahrieel@utem.edu.my

Abstract - Microgrid is a part of the power distribution system which uses renewable energy based of power generation connected to the grid system. Multi energy power generation is composed of renewable energy systems including photovoltaic, wind turbine, energy storage and local loads. Testbed of a microgrid system is the technique to ensure stable operation during faults and various network disturbances in grid and islanding connected mode. In this paper the microgrid using renewable energy consist of a 3 kW photovoltaic, with 30 pieces of 12V for 100Ah battery bank, DC/DC converter, charge controller for battery, single phase DC/AC inverter and various loads (resistor, capacitor, inductor) are develop. The AC buses 240V voltage include with isolation transformer to simulate the grid voltage level by Matlab/Simulink software.

Keywords: Battery Storage, Inverter, Microgrid, Photovoltaic, Matlab/Simulink.

I. INTRODUCTION

Nowadays, microgrid technology using renewable energy based on distributed power generation system combined with power electronic system will produce the concept of future network technologies [1]. The integration of renewable energy sources and energy storage systems has been one of the new trends in power electronic technologies [2]. The main advantages of microgrid development are providing good solution to supply power in case of an emergency and power outage during power interruption in the main grid. Microgrids comprise low voltage distribution system with distributed energy resources, such as photovoltaic power system and wind turbines, together with storage device [3].

Currently, Photovoltaic generators are designed in order to generate a maximum power to the grid. Because of

the stochastic nature of the PV power output, large developments of grid connected PV systems involve large fluctuations of the frequency, power and voltage in the grid [4]. However, the disadvantage is that PV generation is intermittent, depending upon weather condition. Thus, the MPPT makes the PV system providing its maximum power and that energy storage element is necessary to help get stable and reliable power from PV system for both loads and utility grid, and thus improve both steady and dynamic behaviours of the whole generation system [5]. Because of its low cost and high efficiency, the battery can be integrate into PV generation system which can more stable and reliable.

In this paper, microgrid testbed using renewable energy based power generation system which is composed of PV array, battery, power electronic converters, filter, controllers, local loads and utility grid as shown in Figure 1. The paper discusses the detailed modelling of grid connected PV/Battery generation system. PV array is connected to the utility grid by a boost converter to optimize the PV output and DC/AC inverter to convert the DC output voltage of the solar modules into the AC system. Meanwhile, the battery is connected to the common DC bus via a charge controller to support a stable voltage from PV. The proposed model of the entire components and control system are all simulated under Matlab/Simulink software. All simulation results have verified the validity of the models and effectiveness of control method.

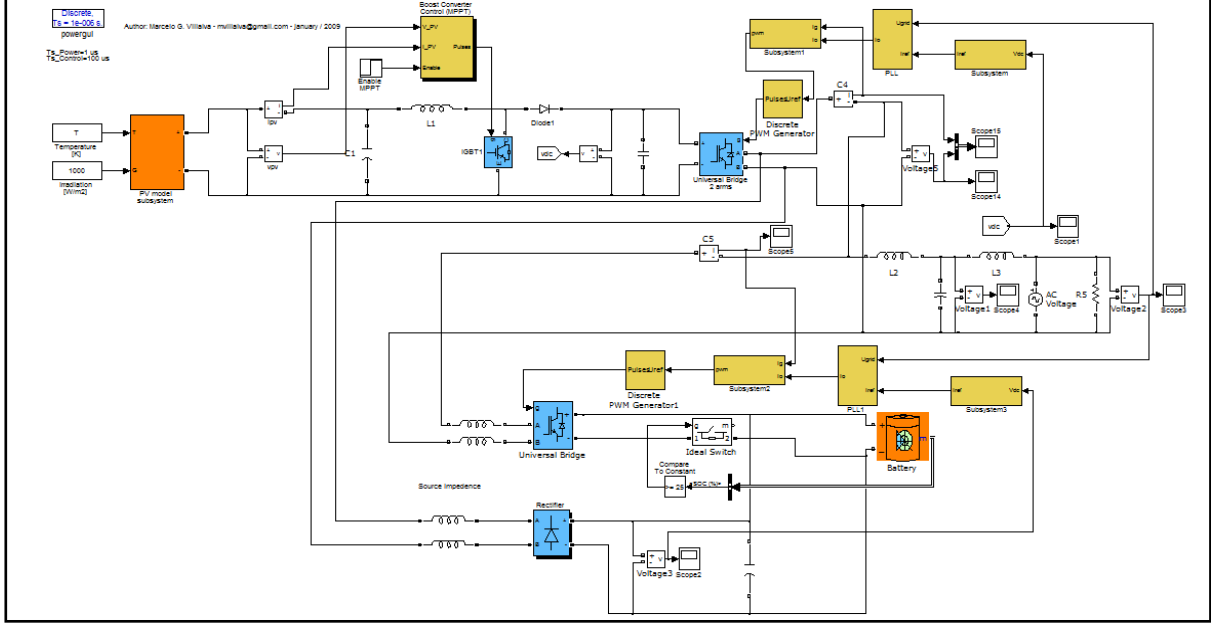

Figure 1: Configuration of the microgrid tesbed using PV and battery based power generation.

II. MICROGRID SYSTEM MODELING

A. Photovoltaic (PV) Model

In this project the PV system is modeling based on the equivalent circuit model which has already state in theory section. The photocurrent generated when the sunlight hits the solar cell can be represented with a current source and the P-N transition area of the solar cell can be represented with a diode. The shunt and series resistances represent the losses due to the body of the semiconductor.

The electrical model of the PV system was simulated in Matlab/Simulink with an equivalent circuit model based on the PV model of Figure 2 and Figure 3.

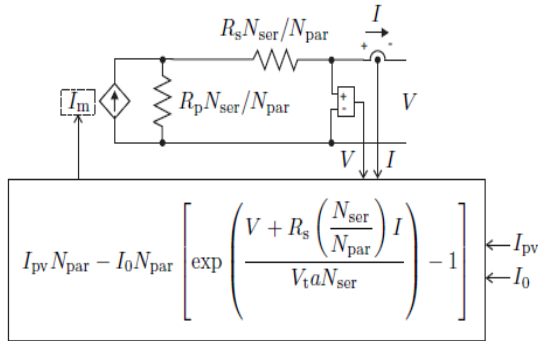

Figure 2: PV system model circuit with a controlled current source, equivalent resistors, and the equation of the model current I_m .

The circuit model is using one current source I_m and two resistors R_s and R_p . The value of the model current I_m is calculated by the computational block that has V , I , I_0 and I_{pv} as inputs. All the input parameters were

developed by using mathematical function that will supplying the information to the PV model circuit based on the mathematical calculation.

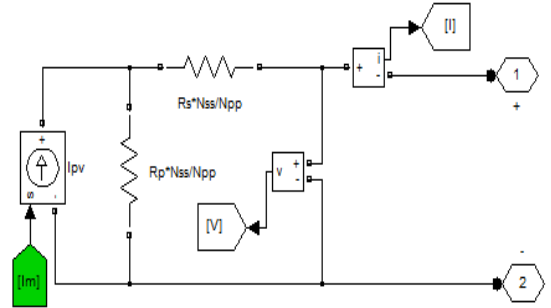

Figure 3: Equivalent model of PV system in Matlab Simulink with input I_m and output port that connect to outside of subsystem.

In order to create the input supply or model current I_m , to the equivalent circuit of PV, firstly the saturation current of I_0 was developed. This is done by using the following equation of 1, 2 and also with the selected parameters. Then the mathematical model of I_0 was developed in Matlab/Simulink as shown in Figure 4.

$$I_0 = \frac{I_{sc,n} + K_i \Delta T}{\exp \left(\frac{V_{oc,n} + K_v \Delta T}{a V_t} \right) - 1} \quad (1)$$

$$V_t = \frac{N_s k T}{q} \quad (2)$$

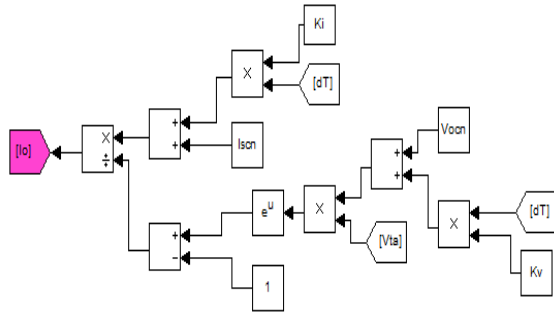

Figure 4: Mathematical model of I_o

Then the light generated current I_{pv} was developed by using equation 3 with the selected parameters. Then the mathematical model of I_{pv} was developed in Matlab simulink as shown in Figure 5.

$$I_{pv} = (I_{pv}, n + K_i \Delta T) \frac{G}{G_n} \quad (3)$$

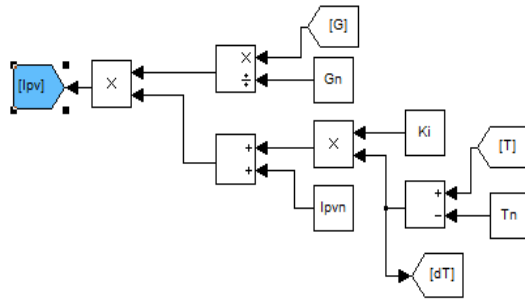

Figure 5: Mathematical model of I_{pv} .

Finally both parameters of I_o and I_{pv} , also with the selected parameter were inserted in equation of 4 in order to obtain the input supply of I_m . Then the mathematical model of I_{pv} was developed in Matlab/Simulink as shown in Figure 6.

$$I_m = I_{pv} N_{pp} - I_o N_{pp} \left[\exp \left(\frac{V + R_s \left(\frac{N_{ss}}{N_{pp}} \right) I}{V_t a N_{ss}} \right) - 1 \right] \quad (4)$$

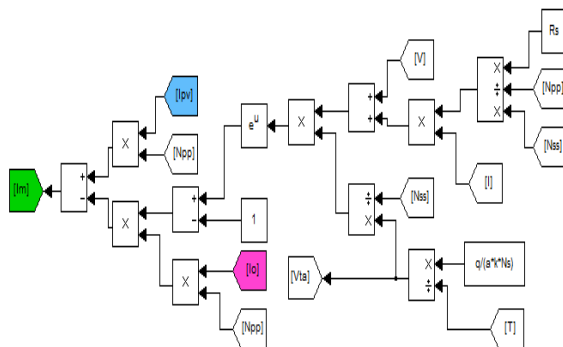

Figure 6: Mathematical model of I_m

B. Boost converter model

In this type of dc converter, the circuit modeling was firstly developed. The boost converter circuit is shown in Figure 7. Then the main parameter such as input and output voltage, inductance value, capacitance value, and resistor value also with the duty ratio were designed.

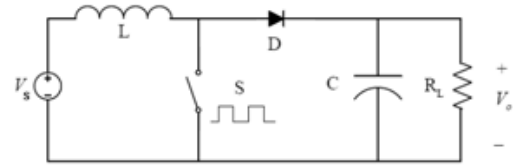

Figure 7: Buck converter topology

Duty ratio D , with desired output voltage V_o and voltage input V_s

$$D = 1 - \frac{V_o}{V_s} \quad (5)$$

Inductance value, L :

$$L_{min} = \frac{D(1-D)^2 R}{2f} \quad (6)$$

By solving for average inductor current and making various substitutions, I_L can expressed as:

$$I_L = \frac{V_s}{(1-D)^2 R} \quad (7)$$

Then the capacitor was selected by using this equation and the output voltage ripple is not exceeding 1 percent,

$$C = \frac{D}{R(\Delta V_o / V_o) f} \quad (8)$$

C. Battery Model

The battery block implements a generic dynamic model parameterized to represent most popular types of rechargeable batteries.

The equivalent circuit of the battery is shown below:

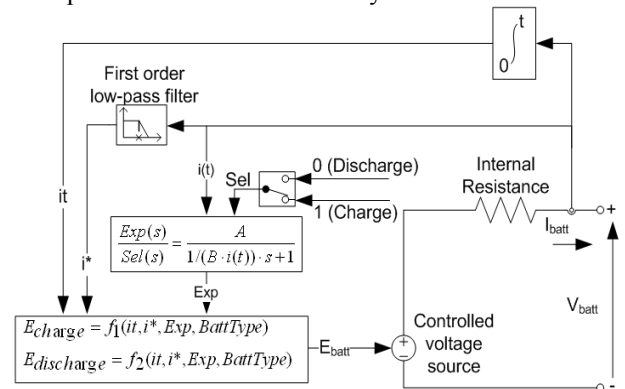

Figure 8: Battery model lead acid type in Matlab/Simulink

Lead acid model for discharge model with selected parameter was inserted in equation 9. While for charge

model with selected parameter was inserted in equation 10.

Discharge model ($i^* > 0$)

$$f1(it, i^*, i, Exp) = E_0 - K \cdot \frac{Q}{Q-it} \cdot i^* - K \cdot \frac{Q}{Q-it} \cdot it + \text{Laplace} - 1 \left\{ \frac{Exp(s)}{Sel(s)} \cdot 0 \right\} \quad (9)$$

Charge Model ($i^* < 0$)

$$f1(it, i^*, i, Exp) = E_0 - K \cdot \frac{Q}{it+0.1Q} \cdot i^* - K \cdot \frac{Q}{Q-it} \cdot it + \text{Laplace} - 1 \left\{ \frac{Exp(s)}{Sel(s)} \cdot 0 \right\} \quad (10)$$

C. Inverter Model

Figure 9 shows outputs from PV and battery connect to inverter, filter and grid system.

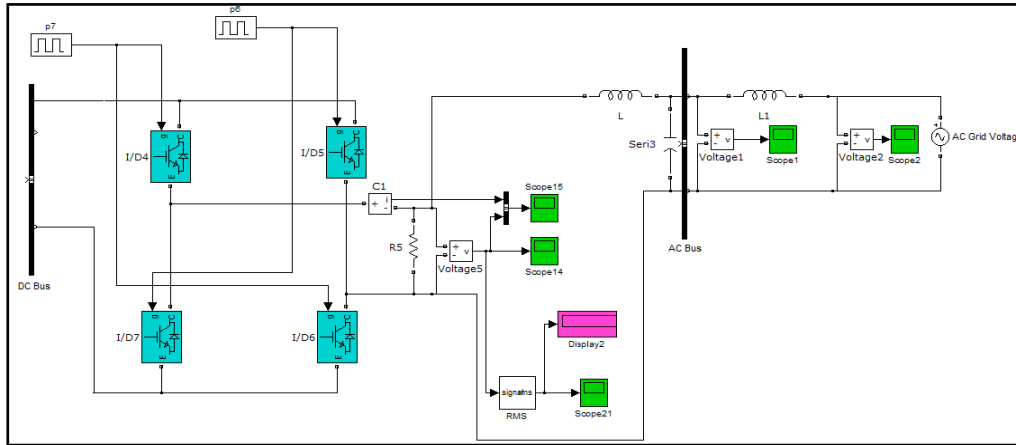

Figure 9: Inverter connects to filter and grid system.

Single phase inverters are used the DC output voltage of the PV array into AC voltage to be connected to the electric utility grid. The single phase full bridge voltage source inverter circuit configuration shown in Figure 9. It is composed of a DC voltage source (PV array) an input decoupling capacitor and four power switching blocks. C is used to filter the noise on the DC bus. After the inverter an LC harmonics filter is used to eliminate the high frequencies in the output inverter voltage. Each block of the switching blocks consists of a semiconductor switch (IGBT) and anti parallel diode. To create proper gating signals for switches, pulse with modulation is used. The functions of PWM are the control output voltage amplitude and fundamental frequency.

III. RESULT AND DISCUSSION

Figure 10 shows the output voltage from PV as a 240V DC voltage. Each solar panel with 9.6V connects in series 25 solar panel for 3 kW.

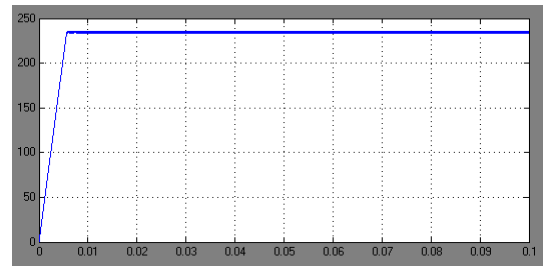

Figure 10: PV voltage

For maintaining supply from PV, battery storage support by charge and discharge the system. Figure 11 shows output from battery 12V for 30 pieces connected in series and the state of charge.

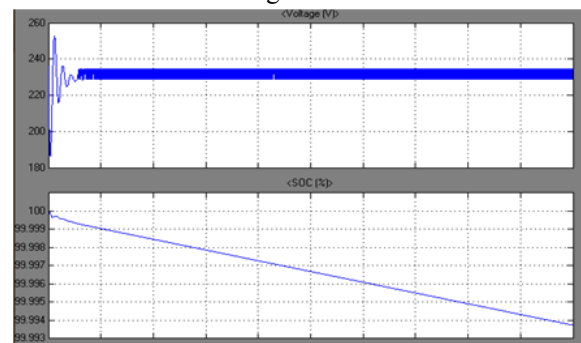
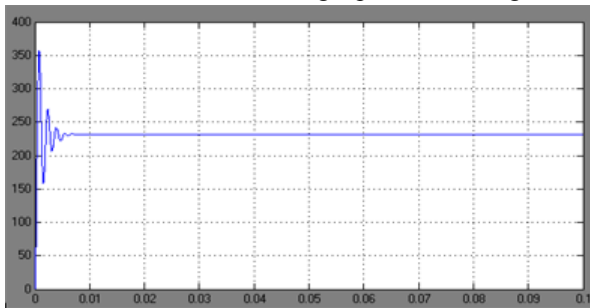

Figure 11: Battery voltage and state of charge

Figure 12 shows output voltage buck converter in DC volts. Here the voltage from PV 240V are fluctuated and buck converter are used to get pure DC voltage.



Figures 12: Output from DC-DC voltage

Figure 13 shows output voltage from inverter before filter in square curve. Here the voltage from DC converter 240V connected to inverter change to AC voltage.

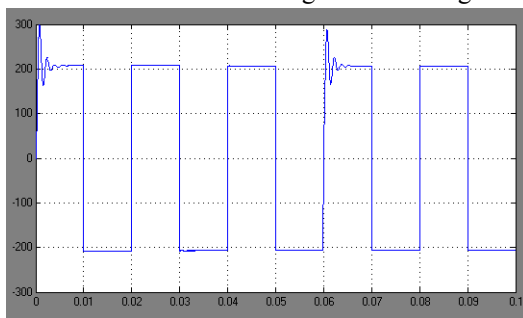

Figure 13: Outputs from inverter voltage before filters

Figure 14 shows output from inverter after filter in sine wave. The inverter works with a pulse width modulation technique. The output voltage of filter is shown as pure sine wave with almost no harmonic content.

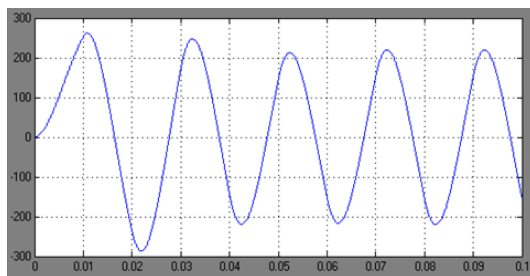

Figure 14: Outputs from inverter voltage after filters

IV. CONCLUSION

In this paper the mathematical model of all system components was introduced in order to investigate the dynamic behavior of each system. Also the proposed control technique of the system was presented. This includes On/Off switch control of the system modes of operation and inverter control. The proposed system components implemented in Matlab/Simulink environment and interface with SimPowerSystem toolbox. The dynamic behavior of each subsystem is investigated showing the interaction between different components of grid connected PV system. Renewable energy based power generation as a photovoltaic (PV) with battery storage for microgrid system are simulated. Simulation is focus on the parameter of the each component to consider the outputs and effectiveness of inverter. Most of the results can be used for develop a small scale microgrid system for practical applications.

REFERENCES

- [1] A.A.Salam, A.Mohamed, M.A.Hannan. 2008. Technical Challenges on Microgrid, *ARNP Journal of Engineering and Applied Sciences*, Vol. 3, No 6: 64-69.
- [2] Seul-Ki, Kim, Jin-Hong Jeon, Chang-Hee Cho, Jong-Bo Ahn, Sae-Hyuk Kwon. 2008. Dynamic Modeling and Control of a Grid-Connected Hybrid Generation System with Versatile Power Transfer, *IEEE Transaction on Industrial Electronics*, Vol. 55, No 4:1677-1688.
- [3] F. D. Kanellos, A. I. Tsouchnikas and N. D. Hatziaergyriou. 2005. Micro-Grid Simulation during Grid-Connected and Islanded Modes of Operation, *International Conference on Power Systems Transients (PPST05) in Motreal Canada*.
- [4] Hicham Fackham, Di Lu, Bruno Francois. 2011. Power Control Design of a Battery Charger in a Hybrid Active PV Generator for Load-Following Applications, *IEEE Transaction on Industrial Electronics*, Vol 58 Iss. 1:85-94.
- [5] M.Makhlouf, F.Messai, H.Benalla. 2012. Modeling and Simulation of Grid-Connected Hybrid Photovoltaic/Battery Distributed Generation System, *Canadian Journal on Electrical and Electronics Engineering*, Vol. 3 No 1: 1-10.
- [6] M. G. Vilalva, J. R. Gazoli "Modeling and Circuit-Based Simulation of Photovoltaic Arrays" *Brazilian Journal of Power Electronic*, 2009 vol. 14, no. 1, pp. 34-35, ISSN 1414-8862.