

PROPOSAL FOR HYBRID PASSIVE COOLING SYSTEM OF BATTERIES IN THE ELECTRIC CAR

N.Tamaldin^{1,a*} and M.F.Abdollah^{2,b}

^{1,2} Faculty of Mechanical Engineering, Universiti Teknikal Malaysia Melaka,
Hang Tuah Jaya, 76100 Durian Tunggal, Melaka, MALAYSIA

^aEmail: noreffendy@utem.edu.my, ^bEmail: mohdfadzli@utem.edu.my

Abstract—This paper addresses the challenges faced by Electric Vehicle (EV) thermal management system and proposed a method to overcome them. Due to the non existence of internal combustion engine (ICE) in EV, the driving mechanisms of conventional cooling system need to be revamped. Therefore, in this paper a combination of liquid cooled, air cooled and phase change material (PCM) cooling system was introduced. The main heat dissipation from EV was identified coming from electric motor, battery module and the electronics controller and components. As this is a preliminary study, the reliability and sustainability of the system need to be further investigated. The investigation would include the, simulation and modeling of heat dissipated from the EV and also the cooling capacity of the proposed cooling system.

Keywords — EV Thermal Managemet, Passive Cooling, Phase Change Material, EV cooling system.

I. INTRODUCTION

Driven by persistent concerns about the global environment, petroleum supplies and prices, interest in advanced and alternative vehicle power train technologies continues grow. Electric vehicles (EVs) are an effective technology for reducing the overall amount of petroleum consumed for transportation.

An EV is propelled by electric motor(s), using electrical energy stored in batteries. EVs operate with a very simple architecture: a battery, charged from an external source, supplies electricity to one or more motors that drive the wheels. Because the torque generated by an electric motor is independent of speed, EVs can operate without gear shifting, and it is often advantageous to connect individual motors directly to the wheels. Furthermore, energy can be recovered during braking by having the motors act as generators and charging the battery. 2010 saw the launch of the first modern EV from a major manufacturer: the Nissan Leaf [1]. It is advertised with a top speed of 145 km/hour and a range of 117 km; adequate for urban driving, but the limited battery capacity and lengthy recharging make it impractical for long journeys.

Effective energy utilization is very important in EVs. Therefore, every component in the EVs should operate at the most ideal condition. In order to achieve the ideal operating temperature for these components, efficient thermal management is essential. The purpose of a thermal management system is to deliver optimum power to EV. An ideal thermal management system should be able to maintain the desired uniform temperature by removing the same amount of heat generated by the sources.

In EV, the three major components that produce heat are battery, controller and motor. However, the battery pack is a key component of their fuel savings potential, and the battery is also one of the most expensive components in the vehicle. Various battery chemistries are being tested and promoted, of which NiMH and Li-ion are, so far, the most promising. The NiMH is the leading battery type for PHEVs since it is presently being used in the HEV market [2]. On the other hand, Li-ion batteries have higher energy densities but they require thermal management solutions for this high-power application. Temperature of the Li-ion battery has to be regulated within the optimum window, failing of which can adversely affect the electrochemical performance of Li-ion cell charge acceptance, power and energy capability, reliability, cycle life, safety and cost [3-5]. The operation of most Li-ion cell is limited to a temperature of 20°C to 55°C. Abuse conditions, such as an operation at high temperatures, steeply accelerate the accumulation of thermal energy in Li-ion cells. Generally air conditioning system cooling system is preferred however showing reduction from 34% to 46% of the vehicle range. Heating was also found to be a threat to the vehicle range from 46% to 68% reduction [8].

For battery cells of higher energy density and greater heat generation, as found in EVs, it is probable that active cooling systems with a liquid coolant will be required [6]. However, using liquid as cooling agent means more mass, has a potential for leaks, need more components, and could cost more. Furthermore, maintenance and repair of a liquid cooled pack is more involved and costlier. In addition to the cost advantage, there is also a reduction size and weight of the modules using air as cooling paths.

More effective, simpler, and less expensive thermal management would assist in the further development of affordable battery packs and increase market penetration of EVs. Therefore, the present paper proposed a new concept of battery thermal management by using a hybrid passive cooling system. Battery thermal management using air and phase change material (PCM) for the Li-ion battery pack has potential to bring benefits, such as passively buffering against life-reducing high battery operating temperatures.

II. PROPOSED METHOD

Figure 1 shows a proposed schematic drawing of the cooling system for the EV. As for the motor, air is achieved by directing/blowing the outside air across the

motor via radiator. Due to the fact that heat generated at high speed would become a thread, liquid cooling system is highly recommended for the electric motor.

Multiple air ducts is an easy way to make a direct intake from in front of the car to the battery pack. This will directly flow the outside air to the battery pack in addition to the PCM. Possibly the straight duct thru passenger compartment can reduce losses. A system fan or original radiator fan can be used to assist airflow, practically during charging time where the car remains stationary. In addition, another fan will be placed near battery compartment in order to assist the hot air draw quickly.

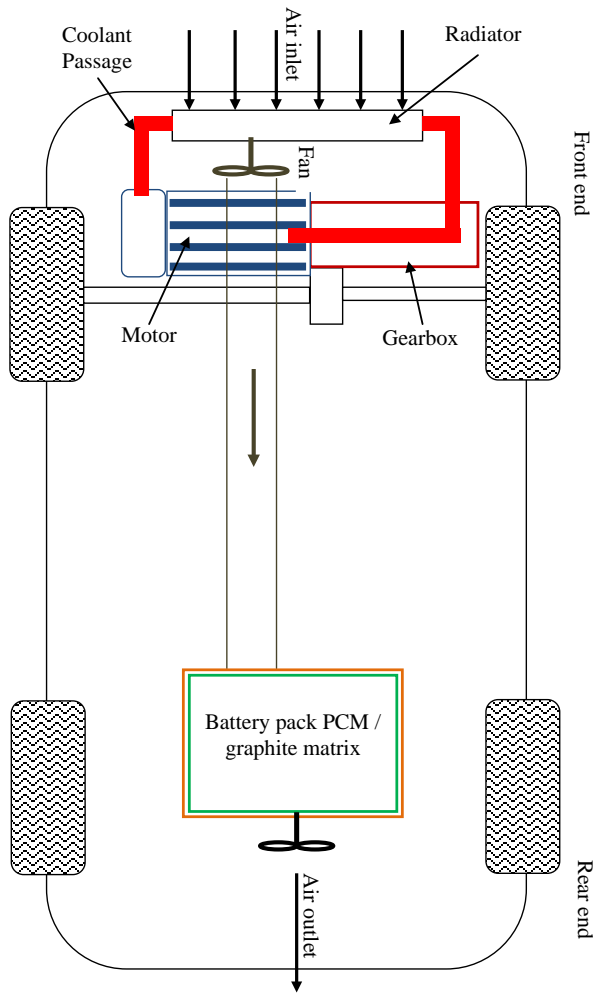

Figure 1 Schematic of the EV thermal management system

The graphite matrix filled with commercial PCM (salt hydrates) will be prepared with Li-ion cells connected in series and parallel configuration to meet the voltage and current requirement of the module. The module will be integrated with safety circuits to regulate cell voltage and prevent over-charge. All of the strings in the module will be connected with a safety circuit that was rated for a required current and potential. The module design, shown in Figure 2, has a porous graphite matrix, impregnated with salt hydrates, that provides structure and heat dissipation. The graphite matrix holds the salt hydrates like a sponge would. The high-conductivity graphite also

provides a low-resistance heat path for effective heat transfer to the salt hydrates. The salt hydrates absorb thermal energy through both the sensible heat and the latent heat of phase change. The battery cells are inserted into the PCM/graphite matrix structure as shown.

III. HEAT TRANSFER SIMULATION AND MODELLING

In developing the EV thermal management system, one of the key area is the heat transfer and cooling capacity modeling of its electric motor, battery module and the electronics components. Three modes of heat transfer considered in EV are conduction, convection and radiation. By identifying the sources of these modes of heat transfer would greatly help to reduce them. An example of hybrid electric vehicle model was used to illustrate the sources of heat transfer as shown in figure 2. In the EV thermal management modeling, the heat transfer from ICE was eliminated.

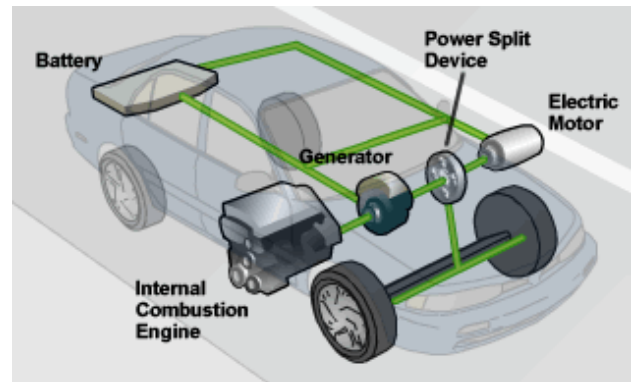

Figure 2. Sources of heat transfer considered [8]

Various thermal predictions were anticipated in order to improve the thermal behavior of the electric motor, battery and electronics component. Each of these components has to meet various thermal conditions for optimization of the operating range. The thermal analysis proposed includes the prediction of various designs to their thermal behavior. Example in figure 3 shows various air flow design impacts on its thermal analysis.

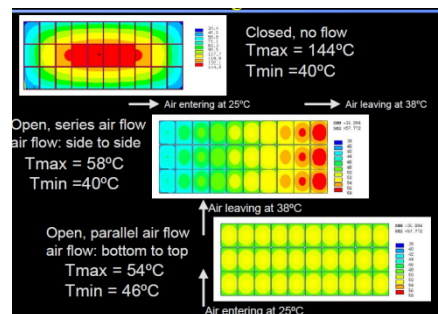

Figure 3. Example of thermal analysis on the battery module [6]

Similar techniques would be applied in this paper with the use of other thermal simulation packages. It is expected that the thermal simulation shown in figure 3 would be a baseline for comparison for our proposed design in this paper.

IV. DISCUSSION

The use of active air and liquid cooling adds considerable complexity and limits the full use of the battery's capacity. However, thermal management using phase change material (PCM) eliminates the need for the additional cooling systems and improves the power use. Battery packs can be maintained at an optimum temperature with proper thermal management, which can be optimized by integrating PCM in the battery. PCM is capable of removing large quantities of heat due to its high latent heat of fusion. In principle, during discharge of the battery, the heat generated could be absorbed by the PCM integrated in between the cells in the battery module. It acts as a heat sink absorbing the heat generated by the battery. When the temperature of the module exceeds the melting point of the PCM (78°C), it starts to melt and the high latent heat of the PCM prevents the battery temperature from rising sharply. This method of thermal management eliminates the need for any kind of manifold, fans, or pumps, which are usually necessary in existing conventional thermal management systems.

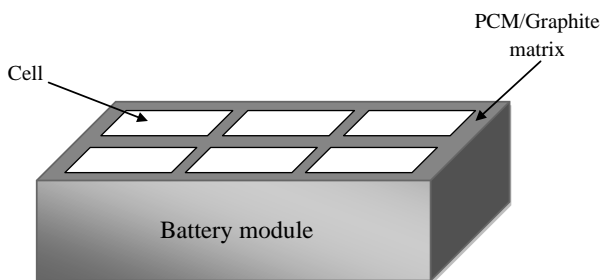

Figure 3 Conceptual schematic of a battery module with PCM/graphite thermal management

V. Conclusions

The study involving EV thermal management have been aggressively explored by the automotive manufacturer in order to be successfully commercialized. The method proposed in this paper may contribute to the development and optimization of the EV thermal management system. The main objective in this development is to have a balance of energy consumption from the thermal management system to the energy utilise to drive the EV. The predictive modelling proposed in this paper could assist in designing a more robust thermal management system for EV with a more economical cost.

REFERENCES

- [1] <http://www.nissanusa.com/ev/media/pdf/specs/FeaturesAndSpecs.pdf>, (Accessed 25 January 2012).
- [2] M. Duvall, Batteries for Plug-In Hybrid Electric Vehicles, The Seattle Electric Vehicle to Grid (V2G) Forum, 2005.
- [3] R. Venugopal, Characterization of thermal cut-off mechanism in prismatic lithium ion batteries, *Journal of Power Sources*, 101 (2003) 231-237.
- [4] G. Ning, B. Haran, B.N. Popov, Capacity fade study of li-ion batteries cycled at high discharge rates, *Journal of Power Sources*, 117 (2003) 160-169.

- [5] A. Pesaran, Battery Thermal models for hybrid vehicle simulations, *Journal of Power Sources*, 110 (2002), 377-382.
- [6] A. Pesaran, S. Burch and M. Keyser, An approach for designing thermal management systems for electric and hybrid vehicle battery packs, *Proceedings of the 4th Vehicle Thermal Management Systems Conference and Exhibition*, 1999, pp. 24-27.
- [7] A. Pesaran, Battery Thermal management in EV's and HEV's: Issues and Solutions, *Proceedings of First annual Advanced Automobile Battery Conference*, 2001.
- [8] J.Rugh, Integrated Vehicle Thermal Management Combining Fluid Loops in Electric Drive Vehicles, U.S. Department of Energy Annual Merit Review, 2011
- [9] J. Horne, Getting "the word" out to the HEV technician about thermal control, *International Conference Thermal Management for Electric Vehicles/HEV*, 27-29 June 2011 Darmstadt, Germany.