

# Design and Development of an Autonomous Underwater Vehicle (AUV-FKEUTeM)

M Shahrriel M Aras, H A Kasdirin, M Herman Jamaluddin, M Farriz Basar, Fakulti Kejuruteraan Elektrik, UTeM

**Abstract**—This paper describes a design and development of an Autonomous Underwater Vehicle (AUV). AUV are robotic submarines that are a part of the emerging field of autonomous and unmanned vehicles. This project shows the design implementation of an AUV as a test bed platform for a variety of research in underwater technologies especially involving small-scale, surface water and low-cost underwater robots. The general design and its consideration are well discussed in this paper. The AUV prototype has been developed by SolidWork. It will have a fixed mechanical system and body, having a modular electronic system that allows development of various controllers. The controller and motors has been tested in small scale surface water and the result is encouraging. Some of the factor affecting the AUV performance is also elaborated for future research in this area.

**Keywords**- Autonomous Underwater Vehicle, Underwater Robotic Vehicle, Unmanned Vehicle.

## I. INTRODUCTION

Robotic submarine i.e. an Autonomous Underwater Vehicles (AUV) is very challenging research area and valued for both their expand ability and replace ability because they can be deployed in hazardous environments without risking human divers. This emerging field is very economical as AUVs has the potential for cheap scalability makes it ideal for large scale and long term data collection tasks. An Autonomous Underwater Vehicle (AUV) is a robotic device that is driven through the water by a

This work was supported in part by the UNIC under UTeM's Short-Term Grant PJP/2006/FKE (7) – S205.

M. Shahrriel M. Aras is a lecturer in the Mechatronics Department, Faculty of Electrical Engineering (Email:shahrriel@utem.edu.my).

H.A Kasdirin is a Head of Control Department in Faculty of Electrical Engineering (email: hyreil@utem.edu.my).

M. Herman Jamaluddin is a lecturer in the Mechatronics Department, Faculty of Electrical Engineering UTeM (email: herman@utem.edu.my).

M. Farriz Basar is a teaching engineer in Faculty of Electrical Engineering and currently on study-leave (email: mfarriz@utem.edu.my).

propulsion system, controlled and piloted by an onboard computer, and maneuverable in three dimensions [1]. This level of control, under most environmental conditions, permits the vehicle to follow precise preprogrammed trajectories wherever and whenever required [1].

Nowadays, many universities all over the world are doing research on Autonomous Underwater Vehicles (AUV). The task of the designers was to develop a concept for an AUV that is smaller and cheaper than existing ones. Sensors on board the AUV sample the ocean as the AUV moves through it, providing the ability to make both spatial and time series measurements [2]. Sensor data collected by an AUV is automatically geospatially and temporally referenced and normally of superior quality [3]. Multiple vehicle surveys increase productivity, can insure adequate temporal and spatial sampling, and provide a means of investigating the coherence of the ocean in time and space [4]. The development of the AUV is presented as an example of the implementation process for a mechatronic product.

In this paper, firstly, it will explain the AUV basic design and development by using computer-aided software called SolidWork and some descriptions on the design concept which has been implemented. Furthermore, the later section discussed the step-by-step development of the AUV and it will end with discussion of some factor that will affect the AUV design and development especially the AUV performance in the deep-sea or underwater.

## II- AUV DESIGN

First, to design an AUV, the project process should be identified as shown in Figure 1. It can be classified into several stages. The first stage concentrates on the design concept of the AUV. The later stages can be described in two sections; the first section is the development of the mechanical structure. Thus, computer-aided software such as the SolidWorks software is used to draw and animate the AUV that are proposed and expected. Another section is the development of the internal and external electrical design of the AUV. The final stage is concluded with its testing, appraisal and minor adjustment of the project. The overall design flows of the design and development of AUV is shown in Figure 1.

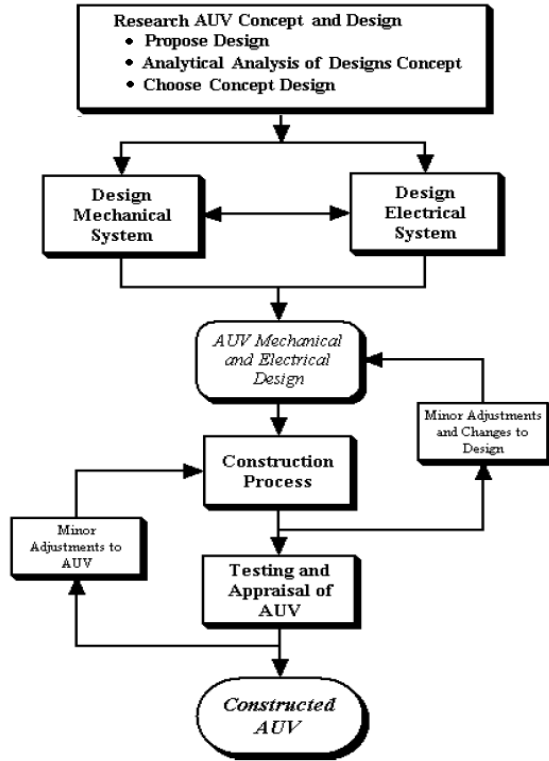

Figure 1: Design and construction of project

### III GENERAL DESIGN OF AN AUV

There are several aspects in AUV electrical and mechanical design need to be looked at closely so that the design will be successful. In order to design any underwater vehicle AUV, it is essential or compulsory to have strong background knowledge, fundamental concepts and theory about the processes and physical laws governing the underwater vehicle in its environment. Therefore, the major design aspects that need to be considered [3] are identifying hull design, propulsion, submerging and electric power. Figure 2 is the method that we are using to design an AUV.

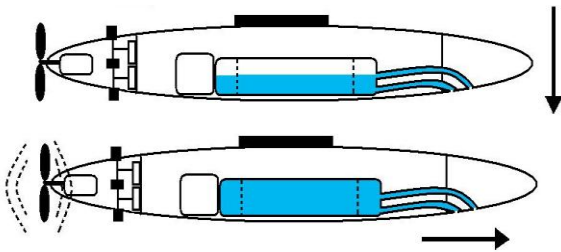

Figure 2: Concepts of AUV

#### A. Hull Design

An AUV must provide a pressure hull to house its components in a dry, watertight environment. The hull must allow components to be easily accessible and maintainable, as well as allowing for modularity in case of future changes or additions [1]. As well as being light and strong, the hull should also be corrosion resistant as it will be subjected to a

harsh saltwater environment. Spherical hulls offer the best structural integrity; however, the shape inhibits the efficient use of the space available as most components and systems are rectangular in shape. So, cylindrical hulls provide the best alternative, comprising high structural integrity and a shape conducive to the housing of electronic components.

#### B. Submerging

In the case of an underwater vehicle, since the volume of the vehicle remains constant, in order to dive deeper, it must increase the downward force acting upon it to counteract the buoyant force. It can accomplish this either by increasing its mass using the use of ballast tanks or iron load and or by using external thrusters.

Ballasting is the more common approach for submerging. This method is mostly mechanical in nature and involves employing pumps and compressed air to take in and remove water as shown in Figure 2. The alternative is to use thrusters that point downwards. This is a much simpler system, but is quite inefficient in terms of power consumption and not really suited at great depths. To reduce the size of ballast tanks or the force required by thrusters for the process of submerging, AUVs are usually designed so as to have residual buoyancy. That is, the weight of the vehicle is made to be more or less equal to the buoyant force. The ability of an object to float depends on whether or not the magnitude of the weight of the body is greater than the buoyant force.

#### C. Propulsion

Some sort of propulsion is required on all AUVs and is usually one of the main sources of power consumption. Most AUVs use motors for propulsion due to the scarcity and cost of alternative systems. The location of the motors affects which degrees of freedom can be controlled. The positioning of the motors can also affect noise interference with onboard electronic components, as well as propeller-to-hull and propeller-to-propeller interactions. Propeller-to-hull and propeller-to-propeller interactions can have unwanted effects in the dynamics of an AUV. When travelling at a constant speed, the thrust produced by the motors is equal to the friction or drag of the vehicle[1], that is

$$Thrust = Drag = 0.5\rho s^2 A_{CD} \quad (1)$$

where  $\rho$  is the water density,  $s$  is the speed,  $A$  is the effective surface area and  $C_D$  is the drag coefficient. Power consumption for the propulsion system increases dramatically as the speed of the vehicle increases. This is because the thrust power is equal to the product of the thrust and the speed, meaning thrust power is a function of speed cubed [1],

$$Thrust Power = Thrust \times s = 0.5\rho s^3 A_{CD} \quad (2)$$

Therefore, because of an AUV's limited energy supply, it must travel at a speed that does not draw too much power, but at the same time does not take too long to complete its mission. Obtaining the ideal speed becomes an optimization problem.

#### D. Electric Power

Electric power is commonly provided via sealed batteries. The ideal arrangement of batteries is to have them connected in parallel with diodes between each one to allow even discharge and to prevent current flow between batteries. Fuses or other protective devices should also be used to prevent excessive current flow in case of short circuits occurring or components malfunctioning. The restrictive nature of power on AUVs influences the types of components and equipment that can be utilized. Components and equipment should be chosen so as to draw as little power as possible in order to allow the batteries to provide more than enough time for the vehicle to complete its mission.

### IV- RESULTS

The AUV can be designed in 3D by using computer-aided software and hence, the SolidWorks is 3D mechanical CAD (MCAD) software used. The software enables the user to play around to make any changes or modification of the model an AUV. Actually this design is finalized after a selected the suitable and best design. Figure 3 is the AUV that design using SolidWorks software. In addition, by using the tools given, the modification could easily handle and Figure 4 shows that the design can be separated. Early design we expect only 2 place can be open so that we can modified or maintenance our AUV.

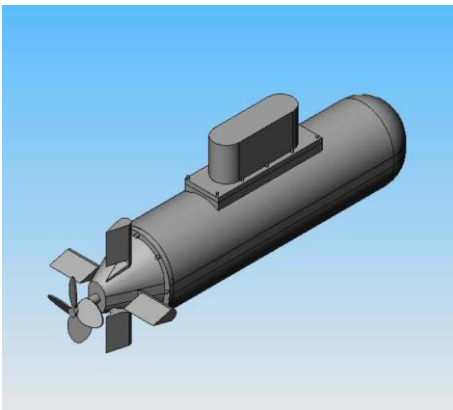

Figure 3: Simulation design using SolidWorks

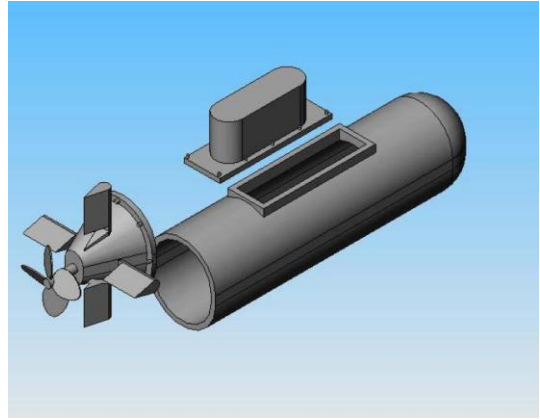

Figure 4: 3D Design using SolidWorks

#### A. Skeletal Frame

The primary structure of the design is making the mechanical parts especially the skeletal frame. The skeletal frame as shown in Figure 5 and Figure 6 is made from aluminium, chosen especially for its lightweight characteristic as well as its resistance to corrosion which helps protect the frame against the harsh saltwater and chlorine environment in which it is subjected to. As well as supporting the two hulls and four motors, the structure of the frame allows for the simple mounting of external devices and components. The design took into account the potential need for additional components in the future and for that reason ample space is available on the frame. The symmetrical and structurally simple nature of the frame design contributed to the relatively straightforward aligning of the thrusters with the centres of drag for increased dynamic stability. The nature of the frame also allowed the thrusters to be easily mounted in positions where they would minimise potential magnetic interference with onboard electronic devices.



Figure 5: Skeletal Frame view side of an AUV



Figure 6: Skeletal Frame front view of an AUV

### B. Fibre-reinforced plastics (FRP)

Once the skeletal frame of an AUV is done, the next process is fibre process. Figure 7 (a) is the process of skeletal frame made up of aluminium enclosed with fibre-reinforced plastics. Figure 7 (b) and (c) is the same process that is the skeletal frame enclosed with fibre-reinforced plastics to make the desired design following the design using the software.

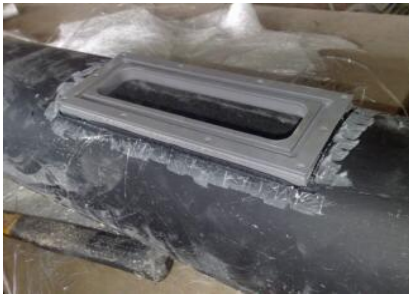

Figure 7(a)



Figure 7(b)



Figure 7(c)

Figure 7: Process of skeletal frame with fibre

### C. AUV dimension

Figure 8 shows the hardware of AUV that the finalized result for design and development of an AUV. The actuators are functioned as well as project expected. Motor for propeller work well controlled by manual controller. It just for rotate clockwise for AUV moving forward. The next planning the motor will be rotate anticlockwise for AUV moving backward. The servo motor in AUV functioned well because the driver for servomotor will be designed for future planning of the project. As informed, the movement of the developed AUV controlled of manual controller. The future plan of the development will be applied autonomous controller so that the developed AUV becoming more intelligent and moving itself.

### V-FACTORS AFFECTING AUV PERFORMANCES

Several forces act on an underwater vehicle that requires consideration for better performances. These include added mass, environment and pressure. Pressure is another significant factor for underwater vehicles that needs to be taken into consideration in the design process.

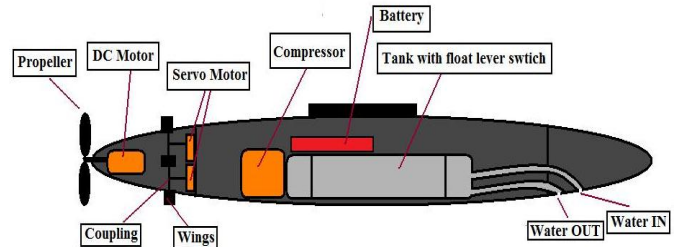

Figure 8: Layout of component in AUV



Figure 9: The final hardware of AUV

### A. Added Mass

Another phenomenon that affects underwater vehicles is added mass. When a body moves underwater, the immediate surrounding fluid is accelerated along with the body. This affects the dynamics of the vehicle in such a way that the force required to accelerate the water can be modelled as an added mass. Added mass is a fairly significant effect and is related to the mass and inertial values of the vehicle.

## B. Environmental Forces

Environmental disturbances can affect the motion and stability of a vehicle. This is particularly true for an underwater vehicle where waves, currents and even wind can perturb the vehicle. When the vehicle is submerged, the effect of wind and waves can be largely ignored. The most significant disturbances then for underwater vehicles are currents. In a controlled environment such as a pool, the effect of these environmental forces is minimal.

## C. Pressure

As with air, underwater pressure is caused by the weight of the medium, in this case water, acting upon a surface. Pressure is usually measured as an absolute or ambient pressure; absolute denoting the total pressure and ambient being of a relativistic nature. At sea level, pressure due to air is 14.7 psi or 1 atm. For every 10m of depth, pressure increases by about 1atm and hence, the absolute pressure at 10m underwater is 2 atm. The increase in pressure as depth increases is significant and underwater vehicles must be structurally capable of withstanding a relatively large amount of pressure if they are to survive.

## V - CONCLUSION

The mechanical and electrical structures of the project have been well discussed and shown in previous chapter. After that, the research result and problem finding also have been described. Therefore, based on the research made, a brief project conclusion of the development process and the design of the actual AUV are given.

Autonomous Underwater Vehicles (AUVs) are robotic submarines. They are a part of the emerging field of autonomous and unmanned vehicles and are primarily used as low cost reconnaissance tools. AUVs are valued for both their expand ability and replace ability; they can be deployed in hazardous environments without risking human divers.

Economically, the potential for cheap scalability makes AUVs ideal for large scale and long term data collection tasks. This research aims to design and develop an AUV as a test bed platform for a variety of research in underwater technologies especially involving small-scale and low-cost underwater robots. The prototype that will be developed will have a fixed mechanical system, having a modular electronic system that allows development of various controllers, recording devices and sensors module.

It also can be used for testing and learning conventional and advanced control algorithms and techniques to other underwater systems. With a limited budget a small autonomous underwater vehicle has been developed. The mechanical structure is produced. Future development and improvement will show that this compared to other AUV projects, smaller and cheaper concept will succeed.

## ACKNOWLEDGEMENTS

We wish to express our gratitude to honorable University (**Universiti Teknikal Malaysia Melaka**) especially to higher management for give the financial as well as moral support. And also would like to thank UNIC because their tolerance for complete this project successfully.

## REFERENCES

- [1] L.A. Gonzalez, "Design, Modelling and Control of an Autonomous Underwater Vehicle," Bachelor of Engineering Honours Thesis, The University of Western Australia, 2004.
- [2] E. H. Rognvaldsson, "Development of an Inexpensive Experimental Autonomous Submarine," Master Thesis in Computer Systems Engineering, University of Southern Denmark, Odense.
- [3] S.Hsu, C.Mailey, C. Montgomery, R.Moody, "Autonomous Underwater Vehicle— "Camera",," Duke & NC state university.
- [4] Bernhard G. , "Development of an Autonomous Underwater Vehicle in an Interdisciplinary Context," Diploma Thesis The University of Western Australia, 2006.
- [5] H.Clarke, E.Crewshaw et. al., "Design and Development of the AUV Harp", Department of Ocean Engineering Florida Atlantic University
- [6] C. von Alt, "Autonomous Underwater Vehicles Prepared for the Autonomous Underwater Lagrangian Platforms and Sensors Workshop," Woods Hole Oceanographic Institution March 24-26, 2003
- [7] Surface ships: Principles of stability. [online], 2004. Available:<http://wrc.chinalake.navy.mil/warfighterenc/SHIPS/shipeng/stability/basics/basics.htm/>.
- [8] T. Fossen, "Guidance and Control of Ocean Vehicles." John Wiley and Sons, United States of America, 1995.
- [9] P. Brutzman, "A Virtual World for an Autonomous Underwater Vehicle." PhD thesis, Naval Postgraduate School, 1994.
- [10] D. Grosset et al. "Quasi-rigid docking of AUV for underwater manipulations." In Proceedings of the 4th International Workshop on Computer Science and Information Technologies, 2002.
- [11] International submarine engineering web based auv designinfo. [online], 2000. Available:<http://www.ise.bc.ca/WADEsysdesign.html/>.
- [12] R. Altschuler. Orca-v: An autonomous underwater vehicle. [online], 2002. Available:<http://www.auvsi.org/competitions/2002/MIT.pdf>
- [13] D. Eaton et al. Nautilus: Evolution of an autonomous underwater vehicle.[online],2003.Available: <http://www.auvsi.org/competitions/2003/WestFlorida.pdf/>.
- [14] J. Buescher et al. Cuauv: Design and implementation of an autonomous underwater vehicle for the 2003 auvsi underwater competition.[online], 2003. Available: <http://www.auvsi.org/competitions/2003/Cornell.pdf/>.
- [15] Cornell university autonomous underwater vehicle. [online], 2004. Available: <http://www.cuauv.org/>.
- [16] M. Makeev et al. Subjugator 2003. [online], 2000. Available: <http://www.auvsi.org/competitions/2003/Florida.pdf/>.
- [17] M. Nguyen."Design of an active acoustic sensor system for an autonomous underwater vehicle." Honours thesis, The University of Western Australia, 2004.
- [18] D. Lim. "A vision system for an autonomous underwater vehicle." Honours thesis, The University of Western Australia, 2004.
- [19] J. Healey and D. Lienard. "Adaptive sliding mode control of autonomous underwater vehicles in the dive plane." In IEEE Journal of Oceanic Engineering, volume 15, pages 152–159, 1990.