



CHILD IN CAR ALARM SYSTEM USING VARIOUS SENSORS

N. M. Z. Hashim, H. H. Basri, A. Jaafar, M. Z. A. A. Aziz, A. Salleh and A. S. Ja'afar

Centre for Telecommunication Research and Innovation (CeTRI), Faculty of Electronic and Computer Engineering, Universiti Teknikal Malaysia Melaka (UTeM), Hang Tuah Jaya, Durian Tunggal, Melaka, Malaysia
E-Mail: nikzarifie@utem.edu.my

ABSTRACT

The network service system is increasingly extended as the demand from various of usage is growing. Although many products had been invented, there are still the incidents that involve to death of children which been left in cars often occur. The system is designed in order to overcome this unwanted incident from happening. The proposed system is designed to detect sound or voice and any movement made by the children that had been left behind in a vehicle. The main target of the system is to create a complete system which uses Global System for Mobile Communication (GSM) that can communicate with human. GSM modem is the medium to interact and communicate with the module. It is used to send and receive Short Messaging System (SMS) based on which appropriate actions taken by the user. PIC microcontroller performs as heart of whole controlling system. The system at the final stage can be used to detect the sound that had been produced by a human at optimum strength. In addition, it was also able to detect motion that performed by a person and can detect any sounds that produced from inside the car. The system that has generated is expected to continue to expand with concomitant change in time with the developed and equipped with a great technology. It is envisaged that the system is able to overcome the problem of accidents involving children that often left in the car.

Keywords: car, global system for mobile communication (GSM), peripheral interface controller (PIC), sensor, short messaging system (SMS).

INTRODUCTION

One of the most recent used in communication system in the present world of technology is Global System for Mobile Communications (GSM). It has become very popular and one of the wireless communication system that is reliable to use. In addition, it is also accessible to be used by people and very user friendly. One of the factors that make this system reliable to use is the cost effective which makes it is affordable to be owned by consumers. Nowadays, there are quite a number of cases where a baby or child had left in a car by their parents inadvertent. The affected from this mistake is most of them are involved in fatal incidents because of shortage of oxygen or the intense surrounding's temperature. In addition, there are also several of incidents where thieves or robbers hiding at the back place of car seat and act to abduct children are abandoned or robbery of the vehicle owner. All of this accident had happened because of the owner's careless intention in checking for any passengers left inside before or after the vehicle have been parked. It also occurs as a result of human nature where they always forget and often think that they ride alone without bringing children together.

However, caution or carefully in all aspects should be practiced to prevent the unwanted incidents to be occurred. To avoid this kind of bad situations happens; the vehicle must be equipped or provided with a device or system that can be warned owner if there were any unwanted activities when the car owner left the vehicle. As the car was left faraway place such as parking lots or shopping mall basements, therefore there is no other way to communicate with the car except through mobile phone connectivity. Hence, the notification system needs to have access to a long-range phone communication such as GSM (Global System for Mobile Communications).

This system needed a technique on how to detect interior's movement or any voice of child that had been left in the car and then send an SMS text message to the parents alerting if any movement or voice occurs. Besides the simplicity of the proposed system, the cost will be reduced as low as possible in order to make it affordable to be installed in any kind of vehicles regardless of their quality or brands. Even though the vehicle's alarm system has been activated, but the main purpose of the alarm is to keep the car safe from outside intrusion, not inside. The proposed system will detect any motion or movement and voice from the vehicle's interior and informed the owner by sending an SMS alert message. The proposed system will make parents more alert if they were leaving their children alone in the car and can avoid from unwanted event occurred.

LITERATURE REVIEW

Fairuz R. *et al.*, reported about the cases that involving the death of a child in a vehicle [1]. It happens almost every year because of negligence committed by parents who often abandons their children alone in a car. The tragic events happen frequently and it makes every person feel scared and worried. When a driver has safely arrived to their destination, they sometimes forget and overlook the presence of children in the car because of his hasty exit from the vehicle. A baby is susceptible to dehydration and this can cause them to become coma or something worse that will cause succumb to death. So, to avoid incidents like this from ever happen, a vehicle must be equipped with an alarm or sensor that can be placed under or on the seat. If an alarm is success to detect the presence of a human body or any movement, it will produce a sound to tell the parents about it.



Figure-1 below shows the flow chart of the steps that are used to activate an alarm if there are children that are left in a car.

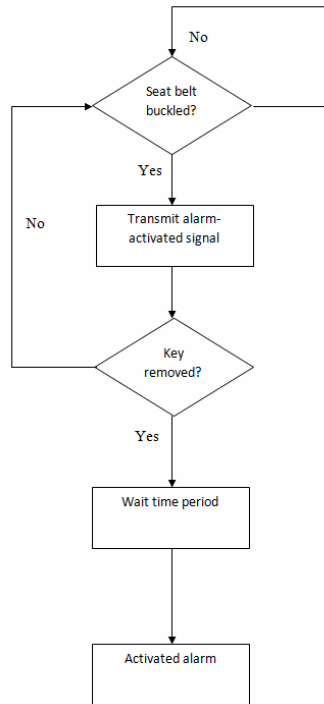

Figure-1. The steps that are used to activate an alarm if there are children that are left in a car.

Greg C. Kautz proposed a system to detect presence of occupants of an automobile [2]. In particular, the invention relates to systems that detect the presence of a child in a child's seat without other passengers and the automobile is not in an operational mode. In this case, to minimize injuries to the child, corrective action is need to be taken. This system is generate the control signals that can activate an alarm, open the doors of the car, and roll down the windows if there is a child in a car that had left.

The system used Radio Frequency Identification or RFID technology in order to detect the presence of the children in a car. The RFID is packaged into a RFID tag that is including an antenna coupled by a switch to the tag electronics. The RFID tag is attached to the child's seat and the tag reader is placed inside the cabin of the vehicle. The communication between the tag reader and the tag is wireless. Figure-2 below shows the schematic for the control system.

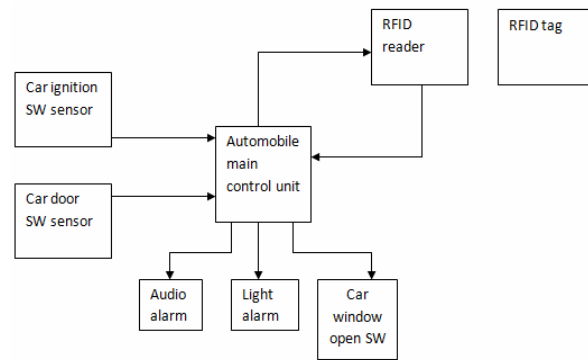

Figure-2. The schematic for the control system.

Marc A. Rossi reported that child safety seats are required by law when transporting young children in motor vehicles [3]. Typically, the child seat is securely positioned in a back seat of the vehicle and the child secured in the child seat via a child seat safety belt. These laws have been established and strictly enforced to protect children from injury when being transported in motor vehicles. However, there have been instances where children have been left behind in unattended vehicles due to various circumstances. Unfortunately, some of these children have suffered serious injuries and in some cases even death, particularly during extreme temperature conditions in the summer and winter.

Figure-3 below is about block diagram of an alarm system that used and can be implementing in this system.

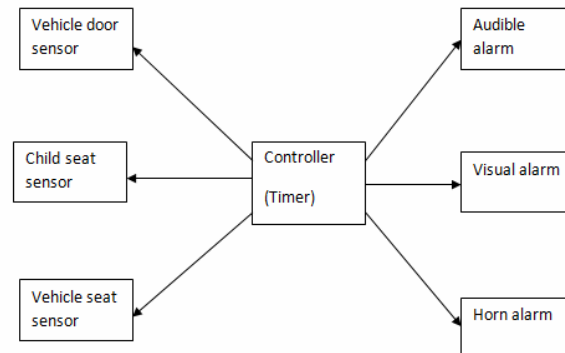

Figure-3. Block diagram of the alarm system.

Fred Mesina discussed the method that is using can help parent or driver in order to always remember that there is a child or pet in their vehicle [4]. There have been many unfortunate cases that always happen every year where people have forgotten that there is a child or pet in the vehicle. The forgotten child or pet will be in extreme danger because of the temperatures inside a parked vehicle can become extremely hot or cold in just a few minutes placing. According to San Francisco State University, there were 49 cases of child deaths due to being left in the car in 2010 alone.



Based on Figure-4 below, it shows the visual cues that are placed and pasted on board at the vehicle surface. It is placed in a very easy place that can help driver to see it from the driver's seat and it is placed near the place where the key is inserted. The device that had been used act as a function to serve as a constant reminder to the driver so that they will always know about presence of the child or pet in their car.

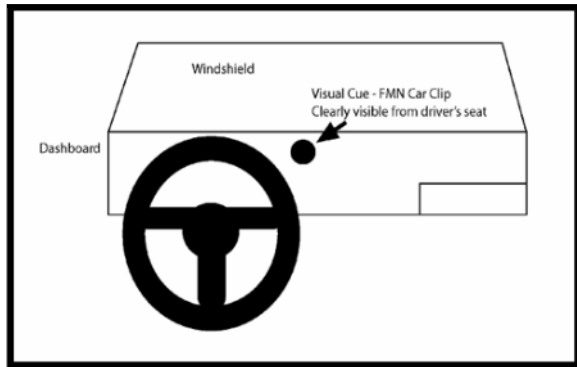

Figure-4. Visual cue that attached to the dashboard.

Joseph Kinman Lee proposed a system to detect any events that often occur due of careless that made by the driver [5]. Previously, the alarm systems are set up to detect what is happening outside the vehicle not to detect something happen in the vehicle. So, the systems that will be created are designed to detect events that occur in a car. The proposed of this system will detect the movements that made by a child who was left in the car and will send a signal message to the owner of the vehicle. The system was produced with low cost and affordable for everyone.

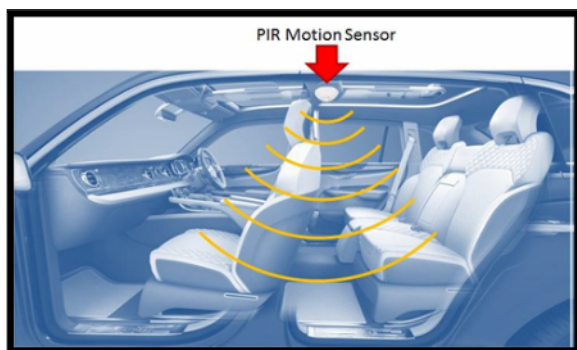

Figure-5. The placement of the PIR sensor.

MATERIALS AND METHODS

This system involved two parts of the implementation as shown in Figure-6. There are the hardware and software development. The proposed notification system is intently to be a simple and low-cost so that it can be easily implemented and installed in any types of vehicle. The system will require a microcontroller, a motion detector and a GSM module for its major components [6]-[7]. The algorithm will also be

kept as simple as possible so that the system can function smoothly without any complex instruction to be performed.

From the Figure-7, it shows how the system works. When the sensor had detected any types of voice or movement, it will send the message to alert parent. The motion sensor needs to be set to trigger when detecting movements that only occurred inside the vehicle during its parking situation. This situation can be set in several conditions such as the vehicle's doors have been locked, the engine ignition is off or the transmission-gear is set to 'P' in automatic transmission vehicle. When a movement is detected, the microprocessor will generate a command with an alert message to the GSM module to be sent to the driver as an SMS text message.

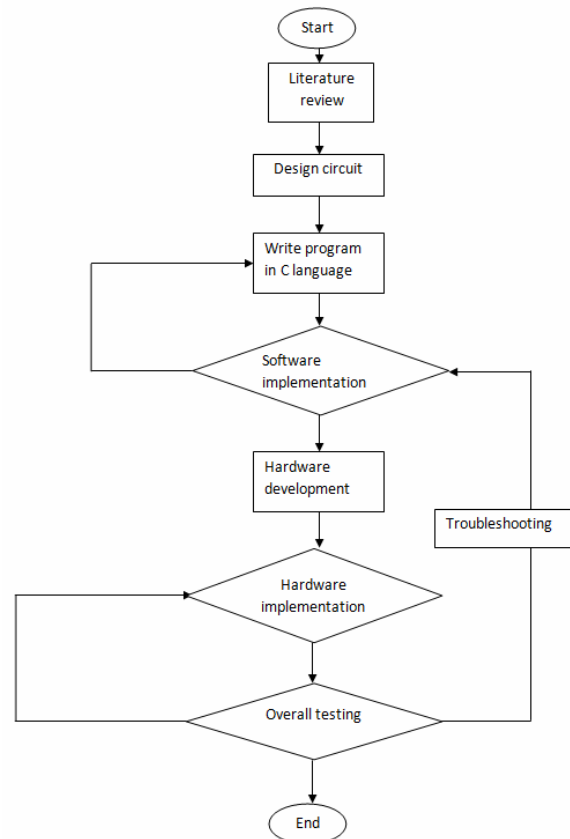

Figure-6. Flow chart of the system.



www.arnjournals.com

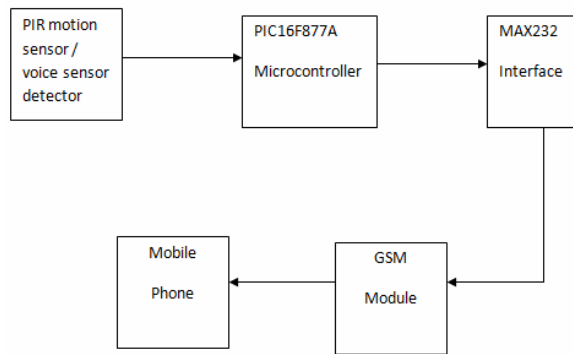

Figure-7. Block diagram.

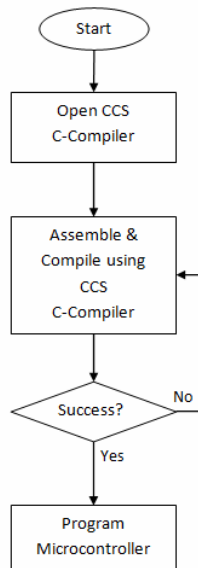

Figure-8. Flow chart of the software development.

From the Figure above, it shows about the process of the software development. In software development, it can be written in C language. The software that is using in order to program this circuit is CCS C-Compiler. In early stage, the Micro C Compiler programming is studied and developed [8]-[9].

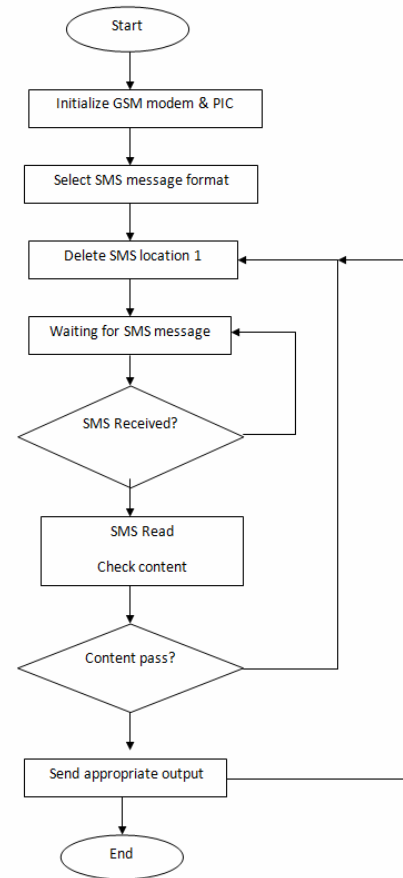

Figure-9. Flow chart of GSM.

Circuit design

In order to build a system and before doing implementation of the hardware or prototype, all the circuit that related to the system need to be design. After all the task done, the circuit is ready to be constructing and after that it must be combined all together to make it as one system. The designs of this circuit are referring to the circuits that were getting from the references journal that are related to this system. In order to make the circuit, all the components that are needed in order to construct the circuit must be study about the function of the components and must choose the right components.

RESULTS AND DISCUSSIONS

Hardware

This car alarm system is proposed to be used by parents to always alert them about their children. By using this system, it can avoid from death cases of dying child increase every year. The death cases are very tragic because it involves child or person that very young. This system is created and develops by using simple components that easy to get in any types of component store. It also comes in very small of product that can easy to install inside the car.



From Figures 10-13 it shows the block diagram of the system and how the system is working. By using PIR motion, it will detect the movement that make by child in a car. The PIR motion will set so that it will detect the motion in the specific range only to avoid from any disturbing from outside of the car. To detect voice, this system used condenser microphone and it also will set to detect voice in specific range. The PIR motion and condenser microphone will set to trigger when detecting

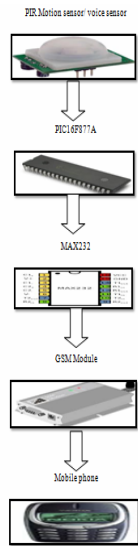

Figure-10. Illustration of the system.

any movement or voice that happen inside the car and during parking situation. It is because to make sure the system can work or function when the engine is off. After it senses either voice or motion, the PIC16F877A will generate a command with an alert message to the GSM module. After it generates command, the message will be send to the driver through their mobile phone.

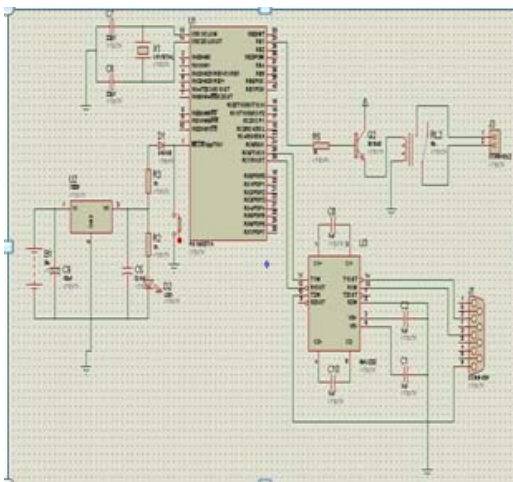

Figure-11. Circuit of the system.

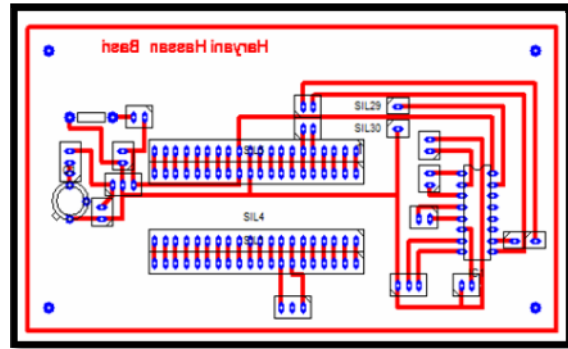

Figure-12. The circuit drawing by using PCB wizard.

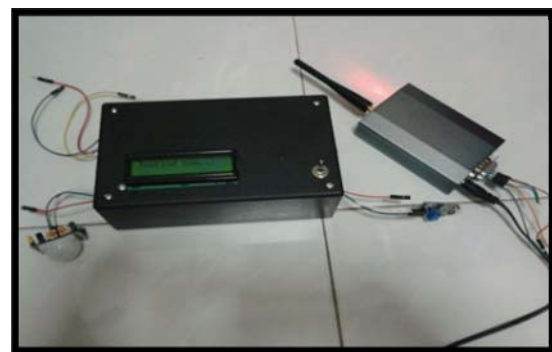

Figure-13. Installation of the circuit and casing.



Figure-14. The function of the system.

Figure-14 above is the message that will appear on the LCD after the motion and sensor is detected. When it detects, the LCD will display the word “Waiting for line ready” and it shows the system is functioning. But, if this word appears for a long time, it means that the system is not functioning well. It happens because of the GSM cannot communicate well with the PIC. If the system works well, it will display the words “Ready”. After this word appears, it will sense any voice and movement and it will send the message through mobile phone.



Software analysis

Software analysis will be discussing on how the C programming operated and function. First, GSM modem and Microchip PIC was initialized. Second, the text mode format, "AT+CMGF=1" command was executed before sending other command. Follow by the SMS at memory location 1 in the sim card of GSM modem was deleted. GSM modem was ready to receive SMS message from user now. Once SMS was received, it will be read and the contents will be checking to make sure the SMS that had receive was in correct or not. The appropriate output to switch on or off the appliances only will be sent if the content no error.

Through hyper terminal, the interface between mobile phone, GSM modem and controlling circuit can be analysis. If the case such as got wrong message receives by GSM modem or connection problem between the hardware, the "ERROR" command will be displayed. Else the "OK" command was showed if no error occurred in the communication interface of hardware.

Software implementation

The software implementation of this system operation was identified. The C programming language on the microcontroller board allows it to transmit and receive data bytes to and from the attached GSM module under the control of the far end phone key board from the remote mobile phone. The decoded message was then processed and used to access the application using digital input/output or digital to analog converter. User sends SMS message to the microcontroller from remote mobile to controlling the home appliances. The microcontroller will then check for any new message. If there is a new message, the microcontroller sends AT Command that is specified for reading the message. Consequently, the microcontroller will save the message in its memory. Then, the message will be compared with other messages that are stored previously. Based on this comparison, the microcontroller will decide which output pins have to be low and which output pins have to be high. The high signal will go to the adaptation circuit and opens the switch causing the home appliances to work. The received message will be automatically deleted.

CONCLUSIONS

As a conclusion to the system, it can be used to detect the sound that had been produced by a human at optimum strength. In addition, it is also able to detect motion that performed by a person in a vehicle. If there is any noise that generated from outside the car, the voice sensor cannot detect the sound that been produced. As if the car door closed tightly, any noise that generated from outside will not be able to detect. In addition, this system also uses Global System Communication (GSM), where it can be used to communicate with people even at great distances. If the sensor is placed in the car managed to detect sound or movement that made by a child who was left in the car, it will continue to work and sending

message to the parents to alert them that their child was left in the car.

The system that has generated is expected to continue to expand with concomitant change in time with the developed and equipped with a great technology. It is envisaged that the system is able to overcome the problem of accidents involving children that often left in the car. With the creation of this system, hopefully parents more responsible for ensuring their children's safety is not compromised. However, the system is capable of being treated to better ensure of the resulting system will become more efficiently.

ACKNOWLEDGEMENT

We are grateful to Centre for Telecommunication Research and Innovation (CeTRI) and Universiti Teknikal Malaysia Melaka (UTeM) through PJP/2013/FKEKK (47B)/S01274 for their kind and help for supporting financially and supplying the electronic components and giving their laboratory facility to complete this study.

REFERENCES

- Fairuz R. M. Rashidi and Ikhwan H. Muhamad. Vehicle's Interior Movement Detection and Notification System. IEEE Journal.
- Greg C. Kautz, 2983 NE. Ivy La., Jensen Beach, FL (Us) 34957-6605. 2010. Method and System for Preventing Leaving A Child in an Unattended Vehicle. August, 31.
- Marc A. Rossi. 2000. Warning System for Detecting Presence of a Child in an Infant Seat. IEEE Journal August 15.
- Fred Mesina. 2005. Baby Seat Belt Alarm System. IEEE Journal, August 2.
- Joseph Kinman Lee and Darren Paul. 2008. Wireless System to Detect Presence of Child in a Baby Car Seat. January, 22.
- Asaad M. J. Al-Hindawi and Ibraheem Talib. 2012. Experimentally Evaluation of GPS/GSM Based System Design. Journal of Electronic Systems. 2(2).
- R. Ramani, S. Selvaraju, S. Valarmathy, R. Thangam and B. Rajasekaran. 2012. water-level monitor for bore well and water tank based on GSM. International Journal of engineering science and technology (IJEST), ISSN: 0975-5462. 4(10).
- Axelsson J. 1998. Serial port complete: programming and circuits for RS-232 and RS-485 links and networks. United States of America: lakeview research llc.
- Bies L. 1997. RS232 serial cables pinout. Retrieved from <http://www.lammertbies.nl/comm/cable/RS-232.html#pins>.