

# A TWO STAGE OF CONCURRENT DUAL-BAND LOW NOISE AMPLIFIER USING CURRENT-REUSED WITH HI-PASS AND LO-PASS MATCHING TECHNIQUE

<sup>1</sup>AHMAD A., <sup>2</sup>OTHMAN A.R., <sup>3</sup>ZAKARIA Z., <sup>4</sup>PONGOT K.

Universiti Teknikal Malaysia Melaka (UTeM), Centre of Telecommunication and Innovation (CETRI),  
Faculty of Electronic & Computer Engineering, Melaka, Malaysia

E-mail: <sup>1</sup>azmanahmad888@gmail.com, <sup>2</sup>rani@utem.edu.my  
<sup>3</sup>zahriladha@utem.edu.my, <sup>4</sup>kamilpongot@yahoo.com.sg

## ABSTRACT

This paper presents the design and analysis of a dual-band low noise amplifier (LNA) at 2.4 GHz and 5.75 GHz for IEEE 802.11 a/b/g applications. This LNA proposed current-reused topology and presented new Hi-Pass and Lo-Pass matching technique network at the two stage common-source transistor. The LNA used GaAs HEMT transistor to improve the gain and noise figure (NF) matched concurrently at the two frequency bands. The simulation results showed a high gain  $|S_{21}|$  of 36.093 dB and 23.152 dB and low NF of 0.735 dB and 0.530 dB for center frequency of 2.4 GHz and 5.75 GHz. The supply voltage for LNA is 2V. Simulation of the design was performed with the Advanced Design System (ADS) software.

**Keywords:** *Low Noise Amplifier, Concurrent Dual-Band, Input/Output Matching, Current-Reused, Hi-Pass Matching, Lo-Pass Matching*

## 1. INTRODUCTION

Recently, multi band RF receiver has been introduced to increase the functionality of such communication systems and receive the different bands at a time. Furthermore, many new wireless communication standards have defined such as monitoring system (Global Positioning System (GPS) and Global Navigation Satellite Systems (GNSS) and etc.), medical electronic device, industrial, home/office appliances (microwave, wireless doorbell, cordless phone, remote sensor and etc.) and communication (WiMAX, LTE, 3G/4G and WLAN). Moreover, there will be more standards for various kinds of applications in the near future [1]. With the development of multi band RF receiver the usability of the receiver for a different standard of applications will be increased.

Today, most of the previous researcher used cascade topology with more than 2 stage amplifier to design the dual band LNA. Furthermore, many of the output gain also have been reported less than 15 dB such as [2] to [5]. With a small signal gain, the output from the front-end receiver signal also will be less or weak. So, it is important to design a high gain and low NF to ensure the stability of the circuit. Therefore, this new design proposes to

improve these criteria using dual-band concurrent LNA.

It is necessary to optimize the front-end receiver performance, especially for the first device at front-end receiver which is LNA. Therefore, this paper introduces a new technique to improve the dual band LNA for IEEE 802.11 a/b/g applications. The front-end receiver should ensure that the signal is received at the receiver front-end with high gain, consumes low power and have an overall low NF.

Figure 1 shows the concept behind the dual-band LNA design. Two front-end receivers with different frequency were integrated into one receiver and become a single LNA with a single signal path. The LNA also has the same circuitry even it can reduce the size of the previous circuit. This approach is implemented with a new design of single stage dual band LNA.

The design concept will be explained in detailed in the following sections. Then, the discussion of the design consideration of a LNA will follow. The detailed simulation and its performance are for gain, noise figure, stability and other parameters are discussed.

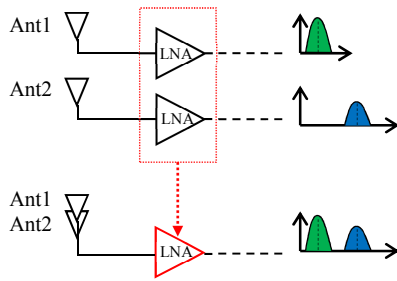

Figure 1. Dual Band Receiver Design

## 2. DUAL-BAND LNA DESIGN

The demand to integrate the multi-band into a single transceiver is to save the die area and power consumption compared to a single stand-alone LNA. In fact the multi-band design also helps to minimize the packaging and testing costs [6]. The LNA may be used in a dual-band configuration where both wireless bands are amplified together in a single device such as in WLAN, LTE, WiMAX and 4G/5G that use multiple different frequency bands. For example WLAN, IEEE 802.11b and IEEE 802.11g all uses the same frequency band which is 2.4 GHz. While the IEEE 802.11a can be used at the 5.75 GHz frequency band. By merging many standards, dual-band wireless will accommodate more available channels, speeding performance, faster bandwidth, less interference and better reliability.

### 2.1 Matching Network Topology

Impedance matching is needed to provide maximum power transfer between the source or RF energy and its load. This is especially important if deal with low signals power. For a good reception every bit of this signal needs to be used and it cannot afford any signal loss, so a perfect matching network is desired. Another reason for the required impedance matching network is to protect the RF circuit, if the RF circuit is not matched some power will be reflected.

There are three basic matching networks used in RF designs which are  $L$ ,  $\pi$  ( $\pi$ ) and  $T$  configuration. Each of them has the advantages and disadvantages. The most commonly matching network been used are  $L$  network because of its simplicity. But the disadvantages of  $L$  network, it cannot match on both load and source more or less  $50\Omega$  because it depends on the reverse  $L$  matching network design.

Thus, an appropriate technique has been proposed in this paper with combination of high

pass  $T$  matching network (Hi-Pass) and low pass  $T$  matching network (Lo-Pass). The combination technique chosen is to provide a wider range of output gain. Hi-Pass circuit consists of three elements, namely, two capacitors and an inductor which configure as shown in Figure 2. The circuit produces high pass signals that begin at the low frequency approximately 2 GHz from the input source. The impedance  $X_{C1}$  allow RF signal into circuit and also prevent DC current flowing through it. At Hi-Pass circuit, the impedance  $X_L$  is to match with the imaginary part ( $-jX_C$ ) that the opposite of  $jX_L$  sign. A good match of inductor and capacitance which will cancel the imaginary part (equal to zero) of each other and then the matching will be completed.

Another matching network at the output load is Lo-Pass circuit as shows in Figure 3. There are also three elements which consist of two inductors and a capacitor. This circuit works to provide the low pass signal and to ensure the output load is match with an optimum conditions through input matching network.

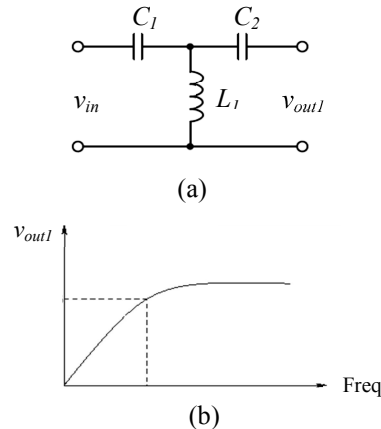

Figure 2. Hi-Pass Network. (A) Circuit, (B) Output

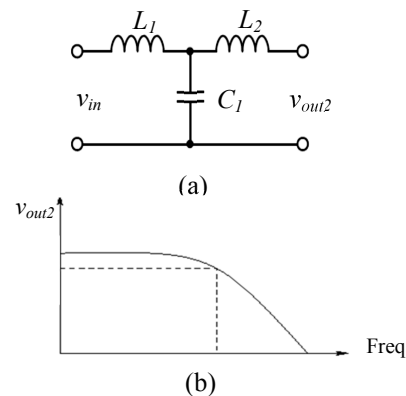

Figure 3. Lo-Pass Network. (A) Circuit, (B) Output

Both input and output impedance matching termination at first-stage amplifier produce a better dual-band LNA output including power gain, stability and noise figure. It is important because the system performance is often strongly affected by the quality of the termination.

**2.2 Current-Reused Technique**

The current reused technique may provide the best combination of high power gain, low noise figure and low power consumption, making it a suitable for use in LNA designs. In an amplifier employing current reused techniques, the input RF signal is amplified by two cascaded common source (CS) amplifier stages to provide high gain as shown in Figure 4(a). At the same time, this technique also supports low noise figures and capable to achieved high performance with low power consumption. In such a design approach, transistors  $M_1$  and  $M_2$  is connected a cascade structure by means of coupling capacitor  $C_1$ . The load inductor  $L_{load}$  and load resistor  $R_{load}$  are the loads for transistors  $M_1$  and  $M_2$ . While currents  $I_{D1}$  and  $I_{D2}$  are the drain currents for transistors  $M_1$  and  $M_2$ . Figure 4(b) shows the schematic diagram for the two stage current-reused CS amplifier, with  $C_2$  used as a bypass capacitor. By comparing the Figure 4(a) and Figure 4(b), it can be seen that currents  $I_{D1}$  and  $I_{D2}$  can be reused as current  $I_D$  and there is just one current path between drain voltage  $V_{DD}$  and ground.

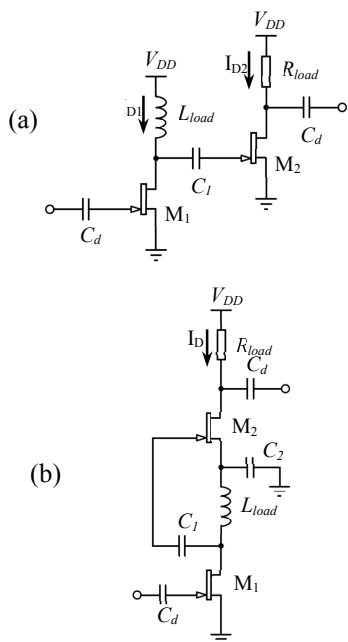

Figure 4. CS Amplifier. (A) Two Cascaded CS Amplifier. (B) Two Stages CS Amplifier With Current Reused Technique

In the experimental current reused LNA, the amplifier technique has been transformed from a two stage CS structure without changing the essential amplifier type, resulting in high gain without adding power consumption.

The basic LNA consists of three stages which are the input matching network, the amplifier and the output matching network [7]. Figure 5 shows a typical single stage LNA with input and output matching circuit. According to [7], the LNA design should meet the criteria required for stability, small signal gain and bandwidth. The initial development of the LNA design can be obtained by deriving the formula and mathematical statements [8].

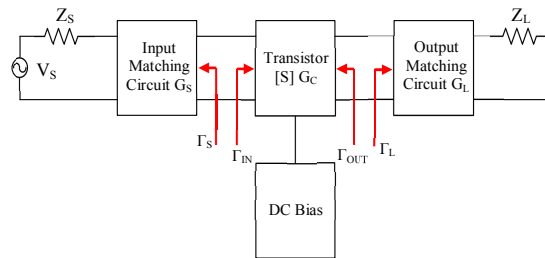

Figure 5 .Typical Single-Stage LNA

The designer must ensure that the input and output matching network of the LNA design is to match the 50  $\Omega$  load terminal. The input and output matching circuit is necessary to reduce the unwanted reflection of signal and to improve the capability of transmission from source to load. The design target specifications for the LNA are shown in Table 1.

Table 1: Targeted S-Parameters For Dual-Band LNA

S-parameter	LNA
Input Reflection $S_{11}$ dB	< -10
Return Loss $S_{12}$ dB	< -10
Forward Transfer $S_{21}$ dB	>+ 17
Output Reflection Loss $S_{22}$ dB	<-10
Noise Figure dB	< 3
Stability (K)	> 1

**2.2.1 Power Gain**

The power gain must be considered as the important parameter to operate the LNA. Figure 6 shows the 2 port power gains with a power network circuit impedance of the LNA. The gains are represented by scattering coefficients classified into Operating Power Gain ( $G_p$ ), Power Transducer Gain ( $G_T$ ) and Available Power Gain ( $G_A$ ) based on [8].

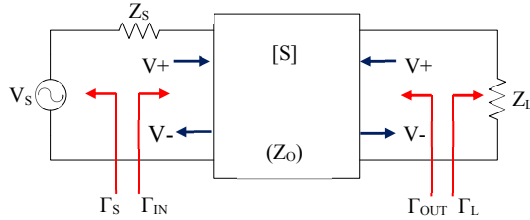

Figure 6. Input And Output Circuit Of 2-Port Network

According to [7], the  $G_p$  is the ratio of the power dissipated in the load  $Z_L$  to the power delivered from the source of the two-port network. The  $G_p$  can be expressed in equation (1).  $\Gamma_{IN}$  is a reflection coefficient of load at the input port of 2-port network and  $\Gamma_L$  is the load reflection coefficient.

$$G_p = \frac{1}{|1-\Gamma_{IN}|^2} |S_{21}|^2 \frac{1-|\Gamma_L|^2}{|1-S_{22}\Gamma_L|^2} \quad (1)$$

While, the  $G_T$  is the ratio of the power delivered to the load to the power available from the source. The  $G_T$  is given by an equation (2).  $\Gamma_S$  is reflection coefficient of power supplied to the input port.

$$G_T = \frac{1-|\Gamma_S|^2}{|1-S_{11}\Gamma_S|^2} |S_{21}|^2 \frac{1-|\Gamma_L|^2}{|1-\Gamma_{OUT}\Gamma_L|^2} \quad (2)$$

The  $G_A$  is the ratio of the power available from the network to the power available from the source and can be obtained by the equation (3).

$$G_A = \frac{1-|\Gamma_S|^2}{|1-S_{11}\Gamma_S|^2} |S_{21}|^2 \frac{1}{1-|\Gamma_{OUT}|^2} \quad (3)$$

### 2.2.2 Noise figure

In an RF communication system the receiver will process very weak signals, but the noise added by the system components tends to obscure those very weak signals. Bit error ratio, sensitivity and NF are the parameters that characterize the ability to process low level signals. Of these parameters, NF is not only for characterizing the entire system, but also the system components such as amplifier, mixer and IF amplifier that make up the system. It provides the dominant effect on the overall system noise performance. Typically, noise figure of 2-port transistor has a minimum value at the specified admittance given by [9] as calculated in equation (4).

$$F = F_{min} + \frac{R_N}{G_S} |Y_S - Y_{opt}|^2 \quad (4)$$

Usually the manufacturers provide  $F_{min}$ ,  $R_N$  and  $Y_{opt}$  data for low noise transistors. The desired noise figure,  $N$  can be determined from equation (5).

$$N = \frac{|\Gamma_S - \Gamma_{opt}|^2}{1-|\Gamma_S|^2} = \frac{F - F_{min}}{4R_N/Z_0} |1 + \Gamma_{opt}|^2 \quad (5)$$

When the stability of the active device is determined, input and output matching circuits should be designed so that a reflection coefficient of each port can be correlated with the conjugate complex number as shown in equation (6) and (7).

$$\Gamma_{IN} = \Gamma_S^* = S_{11} + \frac{S_{12}S_{21}\Gamma_L}{1-S_{22}\Gamma_L} \quad (6)$$

and

$$\Gamma_{out} = \Gamma_L^* = S_{22} + \frac{S_{12}S_{21}\Gamma_S}{1-S_{11}\Gamma_S} \quad (7)$$

The source reflection coefficient should match with  $\Gamma_{opt}$  and the load reflection coefficient should match with  $\Gamma_{OUT}^*$  with a complex conjugate number to obtain a minimum noise figure using 2-port transistor as shows in equation (8) and (9).

$$\Gamma_S = \Gamma_{opt} \quad (8)$$

and

$$\Gamma_L = \Gamma_{out}^* = \left( S_{22} + \frac{S_{12}S_{21}\Gamma_S}{1-S_{11}\Gamma_S} \right)^* \quad (9)$$

### 2.2.3 Dual-band LNA circuits

Figure 7 shows a schematic diagram with the key circuit elements for the dual band concurrent LNA. In this circuit,  $M_1$  serves the role of first-stage amplifier and  $M_2$  are cascaded at the second stage amplifier. Since to keep the noise figure as low as possible, Hi-Pass matching circuit are designed at input stage of amplifier  $M_1$ . While to boosted maximum power transferred and create a specific resonance, Lo-Pass matching circuit is designed at inter-stage of two amplifiers,  $M_1$  and  $M_2$ . A combination of current reused technique and impedances matching techniques using Hi-Pass and Lo-Pass  $T$  matching networks result a better performance for dual-band concurrent LNA topology.

There is one bias circuit for drain voltage at  $M_1$  and  $M_2$  where the drain current  $I_D$  is a reused current. Meanwhile, the resistor  $R_1$ , capacitor  $C_3$  and inductor  $L_{C1}$  form the gate bias circuitry for  $M_1$ . The resistor  $R_2$ , capacitor  $C_7$  and inductor  $L_{C3}$  form another gate bias circuitry for  $M_2$ .

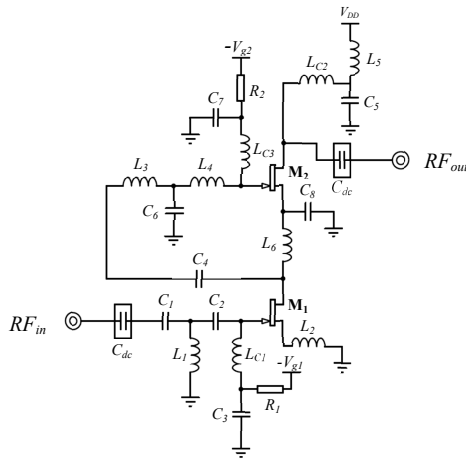

Figure 7. New Dual Band Concurrent LNA Circuit With Current Reused And Hipass-Lopass Impedance Matching Topology

The resistors  $R_1$  and  $R_2$  are set at the current for the bias circuitry, which generates the gate bias voltage at  $M_1$  and  $M_2$ . The choke inductors  $L_{C1}$ ,  $L_{C2}$  and  $L_{C3}$  is to provide a low DC resistance for biasing, and provides high impedance at RF frequencies which isolates the signal from the bias supply [10]. The inductor  $L_6$  provide a high impedance where can block unwanted signal from  $M_2$ .

The capacitors  $C_8$  are bypass capacitors. The value of the capacitor should be large as possible to provide an ideal AC ground. The bypass capacitors AC noise will allow pure DC signals to pass through the circuits. It also prevents the unwanted communication between devices sharing the same power source. The value of the capacitors  $C_{dc}$  was fixed and used as DC blocking capacitor, where to block the DC signal from the input and output lines while allowing passage of RF signals. While capacitor  $C_4$  is a coupling capacitor which is used to couple only the AC signals from  $M_1$  stage circuit to  $M_2$  stage circuit. In the LNA, inductor  $L_2$  are connected as an inductor degenerated topology at  $M_1$  transistor source, it can be seen that a better noise figure reduction at the first stage [11].

### 3. RESULTS

Figure 8(a) shows Hi-Pass matching circuit and Lo-Pass matching circuit structure to attenuate the interferences. The Hi-Pass network is placed before the first stage of amplifier and the Lo-Pass network placed after the stage and brings the matching impedance with wideband gain. The Hi-Pass network use microstrip layout,  $TLI$  to replace the

lump component (inductor) due to controlled and optimized the output by tuning the  $TLI$  length. While the Lo-Pass network use all lump components for the design. Based on the biasing circuit results, the power gain  $|S_{21}|$  and return loss  $|S_{11}|$  versus frequency with differ value of  $TLI$  length are depicted in Figure 8(b).

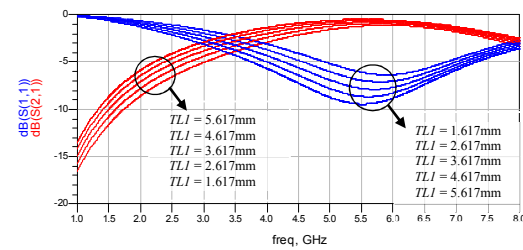
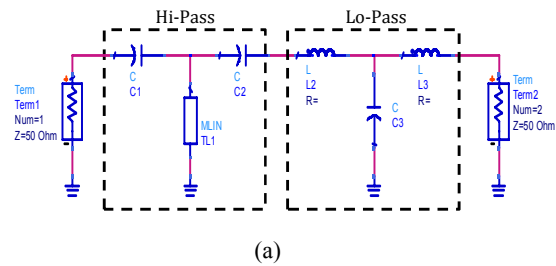

Figure 8. Hi-Pass And Lo-Pass Network. (A) Biasing Circuit Of Hi-Pass And Lo-Pass Structure. (B) Output  $S_{11}, S_{21}$  With Tuning  $TLI$  Length Hi-Pass And Lo Pass Matching Network.

When the  $TLI$  lengths were adjusted, the  $|S_{21}|$  also varies with different values from 1 GHz to 6 GHz frequency. At the same time, the  $|S_{11}|$  also keep changing with different values. The  $TLI$  length increase interval by 1mm with  $|S_{21}|$  increase and  $|S_{11}|$  decrease. While  $TLI$  length decrease, the  $|S_{21}|$  and  $|S_{11}|$  output are changing via versa. It shows that by adjusting the  $TLI$  length, the optimization in term of gain and insertion loss can be achieved.

Figure 9 depicted the results of each  $S$ -parameter data ( $S_{11}$ ,  $S_{12}$ ,  $S_{21}$ ,  $S_{22}$ ) versus the frequency. The return loss ( $S_{11}$ ) obtained -10.420 dB and -11.281 dB at 2.4 GHz and 5.75 GHz frequency. Another results show that the power gain ( $S_{21}$ ) of LNA at 2.4 GHz and 5.75 GHz is 36.093 dB and 23.152 dB, respectively. The reverse reflection ( $S_{22}$ ) and insertion loss ( $S_{12}$ ) depicted each has value -13.616 dB and -50.477 dB at 2.4 GHz; -19.729 dB and -33.150 dB at 5.75 GHz respectively.

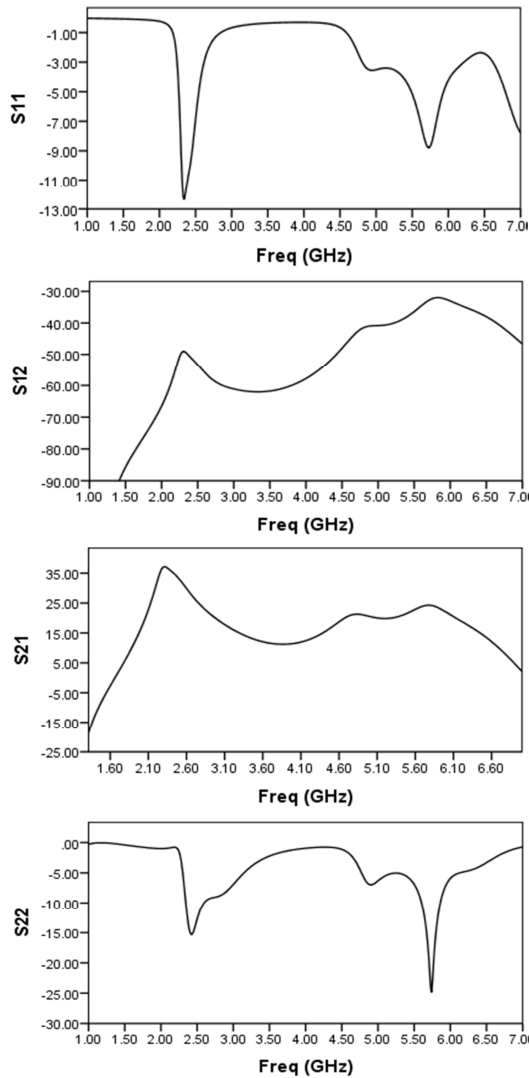

Figure 9. S-Parameter Data ( $S_{11}, S_{12}, S_{21}, S_{22}$ ) Results At 2.4 Ghz And 5.75 Ghz

The NF, stability factor (K) and impedance matching after load matching depicted in Figure 10. The output of NF is 0.735 dB at 2.4 GHz and 0.530 dB at 5.75 GHz. The stability factor obtained 2.079 dB and 2.052 dB at both dual band frequencies which more than 1 dB as targeted in specification. . In order to maintain the LNA in unconditionally stable and to avoid the interference from the input signal, the value of stability factor should keep for  $K > 1$ . The source impedance matching,  $Z_S$  is  $42.196 + j27.960\Omega$  at 2.4 GHz and  $77.081 + j22.512\Omega$  at 5.75 GHz. Meanwhile the output impedance matching  $Z_L$  is  $33.542 + j5.846\Omega$  at 2.4 GHz and  $40.945 - j2.470\Omega$  at 5.75 GHz. Figure 11

shows the layout size (30.5 mm x 77.7 mm) for the proposed dual band LNA.

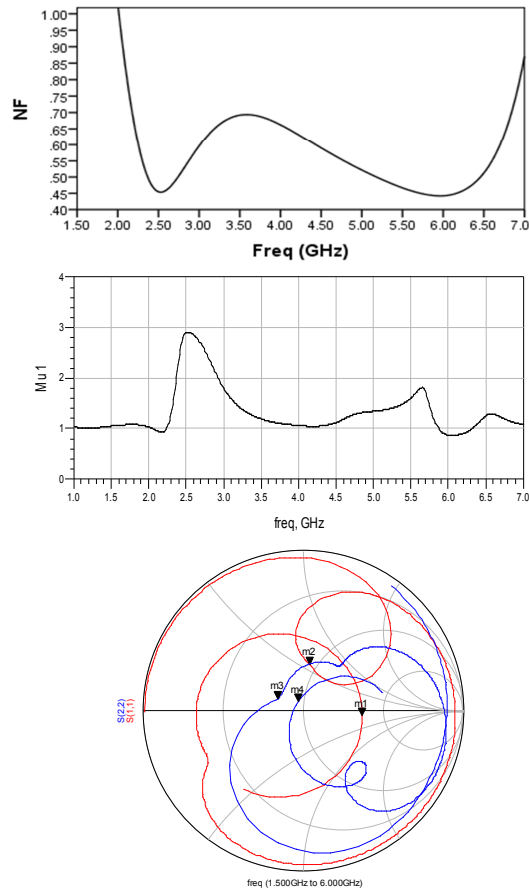

Figure 10. NF, Stability And Impedance Matching Results At 2.4 Ghz And 5.75 Ghz

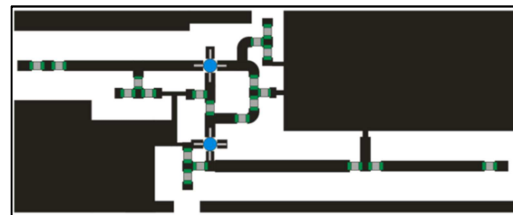

Figure 11. Layout Of Dual-Band LNA

The following Table 2 summarizes the comparison and performance of previous work of dual-band LNA with this present work. It proves that this work demonstrates and achieved the highest gain with lowest NF reduction compared with the previously published dual band LNA.

Table 2: Performance Comparison Of Previously Reported Dual Band LNA

Specification	[12]		[13]	
	2.4	5.2	2.4	5.2
Freq. (GHz)	2.4	5.2	2.4	5.2
S <sub>21</sub> (dB)	23.76	21.41	26.20	21.80
S <sub>11</sub> (dB)	-22.0	-82.0	-23.6	-26.3
S <sub>22</sub> (dB)	-9.05	-18.25	-23.8	-30.4
NF (dB)	1.9	1.0	2.07	1.84

Specification	[14]		This work	
	2.1	5.2	2.4	5.75
Freq. (GHz)	2.1	5.2	2.4	5.75
S <sub>21</sub> (dB)	20.0	14.0	36.09	23.15
S <sub>11</sub> (dB)	NA	NA	-10.42	-11.28
S <sub>22</sub> (dB)	NA	NA	-13.61	-19.72
NF (dB)	2.0	3.1	0.735	0.530

\* NA – Not Applicable

#### 4. CONCLUSION

A new concurrent dual band LNA capable of simultaneous operation at two different frequency bands is introduced. It uses current-reused technique to develop the architecture of the LNA. This design also introduces new matching network which are Hi-Pass and Lo-Pass network and it contribute a high gain and low NF in designed the LNA. The effectiveness of the proposed design achieved a superior NF, stability factor and  $|S_{21}|$  over previously published concurrent LNA. The LNA has two pass bands and can be used for WLAN IEEE 802.11a/b/g application. It also can be used for larger office areas, indoor and outdoor, or full sized house that suited for areas that require more accessibility.

#### 5. ACKNOWLEDGEMENT

The authors would like to express their acknowledgment to the Centre of Telecommunication and Innovation (CETRI) for supporting this project. Special thanks to RAGS/1/2014/TK03/UTEM/FKEKK-B00059 grant Universiti Teknikal Malaysia Melaka (UTeM) for funding this work.

#### REFERENCES:

- [1] Ben Amor, M.; Fakhfakh, A.; Mnif, H.; Loulou, M., "Dual band CMOS LNA design with current reuse topology," *Design and Test of Integrated Systems in Nanoscale Technology, 2006. DTIS 2006. International Conference on*, vol., no., pp.57-61, 5-7 Sept. 2006.
- [2] Kuan-Hsiu Chien; Hwann-Kaeo Chiou, "A 0.6–6.2 GHz wideband LNA using resistive feedback and gate inductive peaking techniques for multiple standards application," *Microwave Conference Proceedings (APMC), 2013 Asia-Pacific*, vol., no., pp.688,690, 5-8 Nov. 2013.
- [3] Dehqan, AR.; Mafinezhad, Khalil; Kargaran, E.; Nabovati, H., "Design of low voltage low power dual-band LNA with forward body biasing technique," *Electronics, Circuits and Systems (ICECS), 2011 18th IEEE International Conference on*, vol., no., pp.591,594, 11-14 Dec. 2011.
- [4] S. Wang and B.-Z. Huang, "A high-gain CMOS LNA for 2.4/5.2-GHz WLAN applications," *Progress In Electromagnetics Research C*, Vol. 21, 155-167, 2011.
- [5] Kargaran, E.; Madadi, B., "Design of a Novel Dual-Band Concurrent CMOS LNA with Current Reuse Topology," *International Conference on Networking and Information Technology, 2010 IEEE International Conference on*, vol., no., pp.386-388, 2010.
- [6] S. Spiridon, C. Dan, and M. Bodea, "Overcoming the Challenges of Designing CMOS Software Defined Radio Receivers Front-Ends Embedding Analog Signal Conditioning," *2012 13th Int. Conf. Optim. Electr. Electron. Equip.*, no. 1, pp. 1207–1210, May 2012.
- [7] Yongguang Lu, Shu-hui Yang, Yinchao Chen "The Design of LNA Based on BJT Working on 2.2-2.6GHz" *2nd International Conference on Signal Processing Systems (ICSPS)*, 2010.
- [8] M. Pozar, David. Microwave and RF Wireless System. Third Avenue, N. Y. John Wiley & Sons, in, 2001.
- [9] Othman A. R, Hamidon A. H, Abdul Wasli. C, Mustafa M. F, Ting J. T. H, Ibrahim A.B, "Low Noise, High Gain RF Front End Receiver at 5.8GHz for WiMAX Application." *Journal of Telecommunication and Computer Engineering (JTEC)*, 2010.
- [10] Ahmad A.; Othman A.R.; Hamidon A.H.; Pongot K, "A High Gain and Low Noise Figure for Dual Band LNA with Notch Filter," *Australian Journal of Basic and Applied Sciences*, 9(5), pp. 55-62, Mac 2015.
- [11] Andreani, P.; Sjoland, H., "Noise optimization of an inductively degenerated CMOS low noise amplifier", *Circuits and Systems II: Analog and Digital Signal Processing, IEEE Transactions on*, vol.48, no.9, pp.835-841, Sep 2001.



- [12] Gupta, S.K.; Garg, A; Singh, N.P., "Design and simulation of an improved dual band LNA for WLAN applications," *Computer and Communication Technology (ICCCT), 2010 International Conference on*, vol., no., pp.678,682, 17-19 Sept. 2010.
- [13] Ahsan, N.; Ouacha, A; Dabrowski, J.; Samuelsson, C., "Dual Band Tunable LNA for Flexible RF Front End," *Applied Sciences & Technology, 2007. IBCAST 2007. International Bhurban Conference on*, vol., no., pp.19,22, 8-11 Jan.
- [14] Si Xiong; Yumei Huang; Zhiliang Hong, "A dual-band 2.1GHz/5.2GHz LNA for reconfigurable radio," *Solid-State and Integrated Circuit Technology (ICSICT), 2010 10th IEEE International Conference on*, vol., no., pp.710,712, 1-4 Nov. 2010.