



# EXPERIMENTAL INVESTIGATION ON PIEZOELECTRIC AND ELECTROMAGNETIC HYBRID MICRO-POWER GENERATOR

Noraini Mat Ali, KokSwee Leong and Ain Atiqa Mustapha

Faculty of Electronic and Computer Engineering Universiti Teknikal Malaysia Melaka, Durian Tunggal, Melaka, Malaysia

## ABSTRACT

Piezoelectric micro-generator (MG) is popular due to its high output power density compared to other means of energy harvesting mechanism; however the current generated is relatively low. In the other hand electromagnetic MG is capable to generate higher output current per unit of electrical output power. By combining both of these MGs, they would complement each other in improving the total efficiency of the energy harvesting system. It is verified from the experiment that the hybrid system reduce the capacitor charging time compared to individual system.

**Keywords:** energy harvesting, micro-generator.

## INTRODUCTION

Hybrid energy harvesting system is a promising technique that extracting energy from two or more sources which has the advantage to deal with the low power sources. Hybrid generator is a combination of any energy harvester such as solar panel and thermoelectric generator [1], piezoelectric and electromagnetic MG [2], solar panel and wind turbine [3]. Hybrid energy harvesting technique can optimize the performance of energy conversion and provide a solution for a low power MGsystem. The focus on this paper is to investigate a hybrid MG based on the combination of piezoelectric and electromagnetic energy conversion mechanisms. The model of a hybrid vibration energy harvester can be simplified as shown in Figure-1, as described by Yu *et al.* [4], where  $b_M$  is a mechanical damping,  $b_P$  is a piezoelectric damping and  $b_{EM}$  is an electromagnetic damping.

The total output power from hybrid system is equal to the sum of the power generated from two kinds of vibration mechanism.

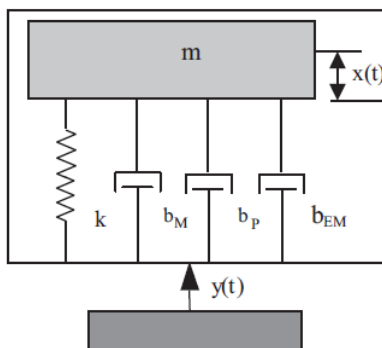

**Figure-1.** Second-order spring mass damper system with additional electrical damper [4].

So, the total output power of hybrid generator consists of piezoelectric and electromagnetic MG can be written as

$$P_{HYBRID} = P_P + P_{EM} \dots\dots\dots (1)$$

where  $P_P$  is the power derived from piezoelectric while  $P_{EM}$  is the power that derived from electromagnetic. The total output power of hybrid generator can be simplified as [4],

$$P_{HYBRID} = \frac{9E_{ac}}{64L^2(\zeta_M + \zeta_P)\omega^2} + \frac{(NlB\omega Y)^2}{16(\zeta_M + \zeta_P)^2 R_{coil}} \dots\dots\dots (2)$$

where  $E_{ac}$  is the modulus of unimorph piezoelectric cantilever beam,  $L$  is the length of the piezoelectric beam,  $N$  is the number of coil turns,  $l$  is the length of coil,  $B$  is the magnetic flux density,  $Y$  is the amplitude of a vibration source,  $R_{coil}$  is the resistance of the coil,  $\zeta_M$ ,  $\zeta_P$  and  $\zeta_E$  are the mechanical, piezoelectric and damping factors respectively while  $\omega$  is the resonant frequency.

The basic design of hybrid harvester as described by Sang, *et al.* [4] consists of one permanent magnet mounted at the end of the cantilever beam which held by two piezoelectric plates. The two coils are located beside both poles of magnet. This system reported able to produce a power of 10.7mW at a resonant frequency of about 50Hz. The result shows that individual electromagnetic generator generates only 5.9mW which is lower than hybrid system. Prior to that, Wischke, *et al* [5] demonstrated that different arrangement of piezoelectric and electromagnetic give different output power, whereby in-line structure generated about 33μW output power at 100Ω optimal load resistance while an across structure generate about 54μW at 200Ω optimal load resistance when excited to the same acceleration of 10mm/s<sup>2</sup>. The improved version with using two magnets mounted on the top and bottom, and at the end of the piezoelectric cantilever beam, generates an output power of up to 60μW at an optimal load of 200Ω. Fauzi, *et al* [6] proposed of using four poles magnets attached on the top and bottom of the piezoelectric cantilever beam with coil was placed underneath the bottom magnet, which is quite similar with in-line structure proposed by Wischke *et al* [5], but arranged in opposite polarity with the coil is placed between the air gap of magnets generated greater electrical output power compared to that of two poles magnets. Obviously besides than increasing the magnetic field, the



four poles magnets also increase the proof mass and therefore generating higher electrical output. Ulsan *et al.* [6] and Yang *et al* [7] describes a design of hybrid energy harvester using axial magnetization permanent magnet spring structure, whereby the electromagnetic part is mounted on the cantilever beam where the piezoelectric is attached on the bottom and top of the cantilever beam. The output voltage generated from this hybrid harvester is 3.134V at 20Hz which is higher compare to stand-alone generator of piezoelectric and electromagnetic.

There are many other configurations of hybrid harvesters using piezoelectric and electromagnetic mechanisms as a complete system [8, 9]. Each of the design derives different results in term of output voltage and output, depends on the size and also the amplitude of oscillation as well as the proof mass attached to the tip of the cantilever, which still does not have a standard merit to compare among all these hybrid energy harvesters.

## RECTIFIER CIRCUITS

Piezoelectric and electromagnetic MG convert mechanical energy into useable electrical energy. Generally, the stand-alone harvester can generates an AC voltage in the range mV to less than 3V. The alternating signal (AC) from the harvester must be rectified into a direct signal (DC) for most of the electronic applications.

Many solutions through various schemes have been introduced to increase the efficiency of the rectifying circuits. Basic energy harvesting circuit typically uses a conventional full bridge diode rectifier. Sang *et al.* [10] presented a piezoelectric and electromagnetic MG as a hybrid generator which are connected in parallel before feeding into full bridge diode rectifier circuit at resonant frequency of 50Hz. In another study, a step down DC-DC converter is used to harvest energy from piezoelectric generator after rectified the AC input using a diode-based rectifier [6]. Although many researchers have reported using this conventional diode-based rectifier circuit, but the power loss during rectification makes this configuration ineffective. The forward voltage drop is the main concern in rectification when diodes are being used. The diode forward voltage drop if 0.7V for silicon diode, 0.3V for germanium diode and 0.2V for Schottky diode. Thus, this conventional rectifier circuit is not efficient for low output voltage harvester.

The power conversion efficiency can be improved by reducing the voltage drop of a diode, which can be achieved by replacing with MOSFET [11]. Peter *et al.* [12] demonstrated using MOSFET bridge rectifier with minimum voltage loss. Szarka *et al.* [13] proposed a two stage rectifier. The first stage consists of PMOS and NMOS transistors which construct in full bridge configuration. It used to convert the negative sinusoidal signal into positive signal. However in bridge configuration, MOSFETs are not fully turned ON and OFF. Consequently, the voltage drop of the devices can increase and reduce the conversion efficiency.

Active rectification using the active switching approach has shown great promise in overcomes a voltage drop issue of a passive semiconductor diode. This is

typically performed using the active diode consists of op-amp and MOSFET. The use of active diode can reduce the conduction voltage drop and allow a very low input voltage to operate. By comparing with passive diode, active diode has a higher current handling capability due to larger gate and source voltage [14]. It had also been demonstrated that with the use of an active diode and negative voltage converter work as active rectifier with minimum input peak voltage 0.35V [12]. The power conversion achieves efficiency over 90% which the active diode consists of a comparator and PMOS in the second stage of rectifier. However, Herbawi *et al.* [15] have proposed the similar design; the two stage of full-wave rectifier using a nonlinear comparator to driven a PMOS. The conversion efficiency achieved a maximum 94%. In contrast, the circuit can rectify the input signal in range of 0.5 to 1.2V. Besides than rectifying, it is also critical in generating higher voltage to charge super capacitor, There has been reported using voltage doubler in rectifying an input voltage as low as 5mV [16].

## EXPERIMENTAL SET-UP

The hybrid system is built by attaching an electromagnetic MG at the flexible end of a piezoelectric plate and the other end of the plate will be rigidly clamped on a platform. When vibration source is applied, the plate will oscillate as a cantilever. The piezoelectric plate used in this experiment is shown in Figure-2, obtained from Piezo System Inc.

The electromagnetic MG consists of a magnetic coil and magnets. Four rectangular shaped magnets are arranged in opposite polarities at the end of the cantilever beam as shown in Figure-3 (a) and (b). Each of magnets has geometry of 25 x 5 x 10mm. The position of the magnetic coil is fixed to the center of the cantilever, where the magnets are held. The magnets that are being used are neodymium iron boron, NdFeB with a mass of 15g each. Besides than being part of the electromagnetic MG, it is also acting as a proof mass to reduce the resonant frequency of the system while increasing the electrical charge generation. BELDEN 8057 with AWG number 34 is being used to make the magnetic coil with about 1330 turns.

The hybrid MG is then mounted on an electrodynamic shaker as shown in Figure-4. The electrical output terminals from both the piezoelectric and electromagnetic MGs are connected in four different configurations to investigate the output voltages generated by the MG when an electrodynamic shaker is being excited to the resonant frequency of the device. The connection configurations are: individual direct measurement with digital oscilloscope, series and parallel connections between the electromagnetic and piezoelectric MGs, and finally connecting to rectifying circuit to investigate the performance of charging a capacitor.

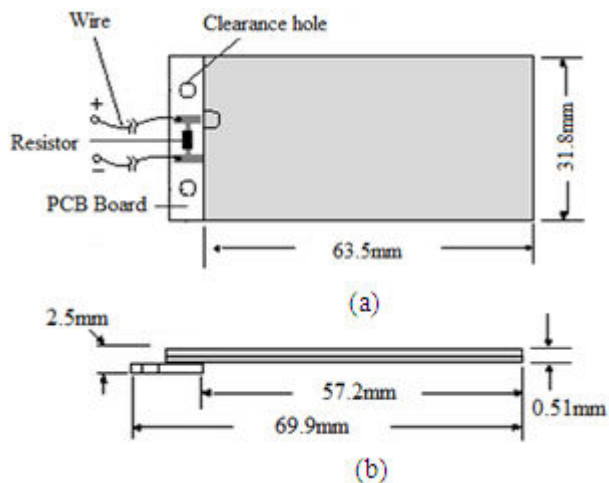

**Figure-2.** Q220-A4-503YB piezoelectric cantilever from Piezo System Inc, with its dimensions from (a) top view and (b) side view.

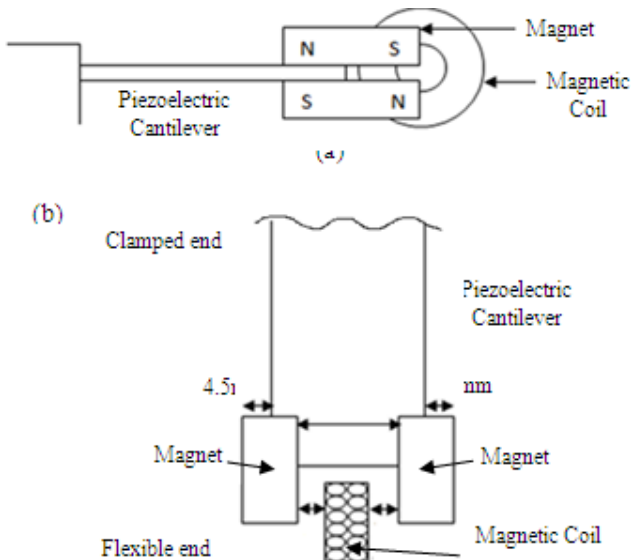

**Figure-3.** Schematic diagrams of (a) a side-viewed, and (b) a top-viewed electromagnetic MG attached at the end of piezoelectric cantilever with fix-positioned magnetic coil.

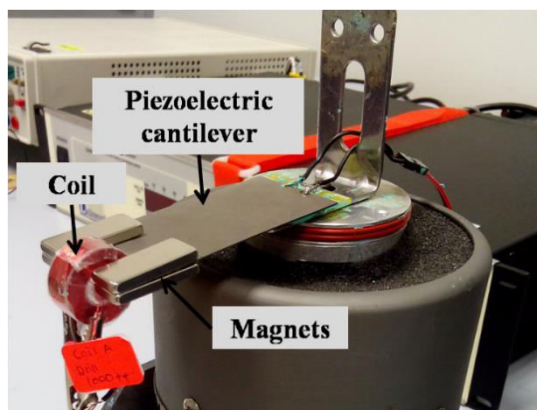

**Figure-4.** Photograph of hybrid MG mounted on an electrodynamic shaker.

## EXPERIMENTAL RESULTS

The resonant frequency of the hybrid MG is determined to be around 25Hz as shown in Figure-5, generating maximum open circuit voltage near to  $0.6V_{rms}$  when excited to an acceleration level of  $0.05g$ . All of the following experiments are done at its resonant frequency to produce a consistence comparison. As expected, Figure-6 shows that the open circuit output voltage is proportional to the acceleration level, whereby piezoelectric performs better than its electromagnetic counterpart.  $4V_{rms}$  is being recorded when piezoelectric cantilever is vibrated to its resonant at  $0.5g$ , whereas electromagnetic MG only generates  $0.3V_{rms}$  at the same vibration acceleration level.

In order to investigate the overall maximum output power that can be generated from the hybrid MGs, it is worth to determine the performance of each individual MG. Figure-7 shows the direct measurement of AC output power from piezoelectric and electromagnetic MGs when connected individually to external resistive load. It shows that the maximum output power of  $0.75mW$  is generated by piezoelectric MG when connected to an external load of  $15k\Omega$ , while electromagnetic MG can generates similar level of output power, depends on the arrangement of the magnets and the magnetic coil, but at much lower resistive load. This clearly shows that piezoelectric MG generates higher output voltage but lower electrical current due to its high resistance compared to electromagnetic MG, which generates higher current.

Figure-8 shows the output power generated by the individual MG in comparison to the output power generated by series and parallel connections of both of the MGs without rectification. It shows that direct connection either series or parallel between piezoelectric MG and electromagnetic MG neither increase nor decrease the total output power generation. Individually connected piezoelectric MG has a superior performance compared to series connected piezoelectric and electromagnetic MGs, while parallel connected MGs perform better than individual connected electromagnetic MG.

Both of the MGs can complement each other in improving the performance of energy harvesting from vibration sources only when they are rectified before being used to charge a capacitor. Figure-9 shows that the hybrid MG performs better than individually connected piezoelectric and electromagnetic MGs after rectification. Figure-10 shows that the charging time for a hybrid MG is faster than individually connected MGs. For example, hybrid MG is taking 400s to charge a  $3000\mu F$  capacitor to 3V compared to piezoelectric MG, which took 600s.

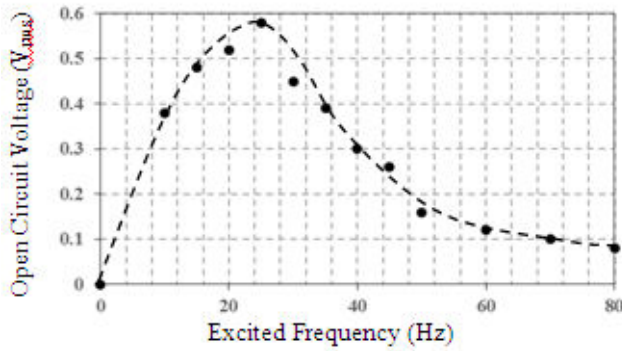

**Figure-5.** Frequency response of piezoelectric open circuit voltage output at an acceleration level of 0.05g.

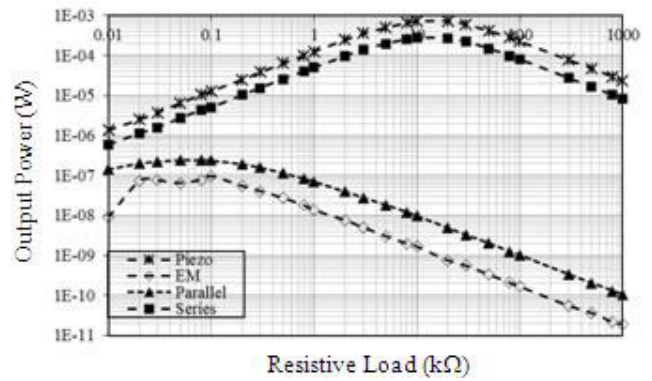

**Figure-8.** Output power as a function of resistive load for different configurations of MGs.

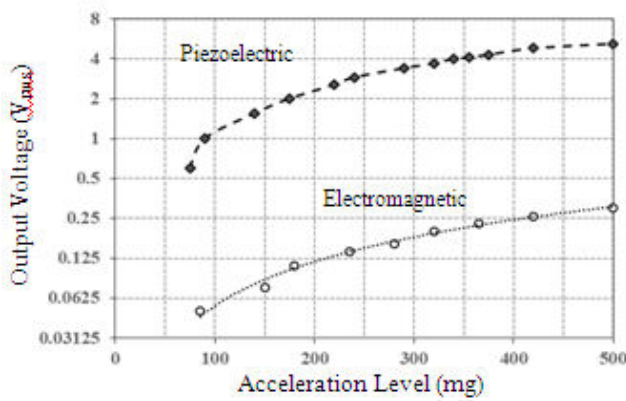

**Figure- 6.** Output voltage of piezoelectric and electromagnetic MGs at a range of acceleration up to 0.5g.

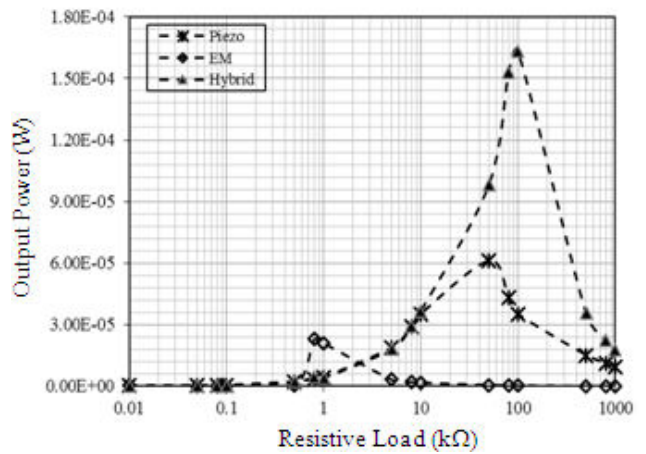

**Figure-9.** Rectified output power from three different configurations of MGs at varying resistive load.

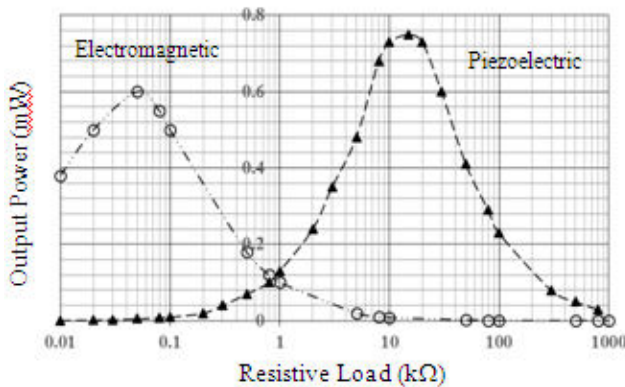

**Figure-7.** Output power of piezoelectric and electromagnetic MGs at resonant with an acceleration of 0.03g.

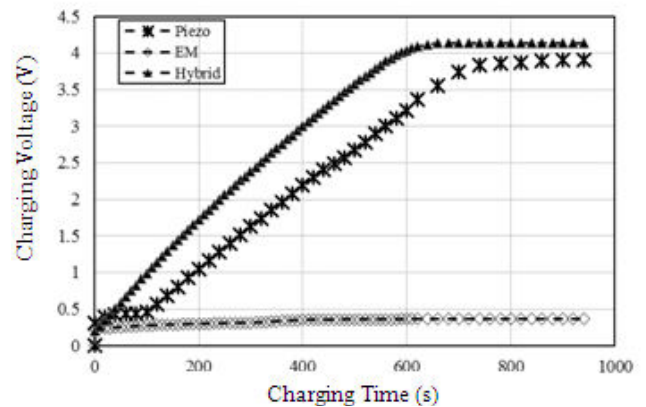

**Figure-10.** Capacitor charging performance of three different configurations of MGs using 16 V capacitor with capacitance of 3000  $\mu$ F.

**CONCLUSIONS**

From the experiment, it proves that hybrid micro-generator performs better than individual connected piezoelectric and electromagnetic micro-generators after rectification in term of faster capacitor charging time. Direct connection either series or parallel between both of



the micro-generators would not increase the total output power of the system.

#### ACKNOWLEDGEMENTS

The authors would like to acknowledge the support of this work by Univresiti Teknikal Malaysia Melaka and the Malaysian Ministry of Education under Grant No. PJP/2014/FKEKK/PROTOTAIP/S01381 and FRGS/2/2014 /SG02/FKEKK/02/F00244 and also the facility support by Advanced Sensors and Embedded Systems (ASECs) Research Group, Center of Excellence for Telecommunication Research and Innovation (CeTRI), Universiti Teknikal Malaysia Melaka (UTeM).

#### REFERENCES

- [1] Y.K. Tan, S.K. Panda. 2011. Energy harvesting from hybrid indoor ambient light and thermal energy sources for enhanced performance of wireless sensor nodes. *IEEE Transactions on Industrial Electronics*, 58(9) 4424-4435.
- [2] M. Wischke, M. Masur, F. Goldschmidtboeing, P. Woias. 2010. Piezoelectrically tunable electromagnetic vibration harvester. *IEEE 23<sup>rd</sup> Int. Conf. on Micro Electro Mechanical Systems (MEMS)*, 1199-1202.
- [3] J. Hui, A. Bakhshai, P.K. Jain. 2010. A hybrid wind-solar energy system: A new rectifier stage topology. *25<sup>th</sup> Annual IEEE Applied Power Electronics Conference and Exposition (APEC)*, 155-161.
- [4] H. Yu, J. Zhou, X. Yi, H. Wu, W. Wang. 2015. A hybrid micro vibration energy harvester with power management circuit. *J. Microelectronic Engineering*, 131, 36-42.
- [5] M. Wischke, M. Masur, P. Woias. 2009. A hybrid generator for vibration energy harvesting applications. *15<sup>th</sup> Int. Conf. on Solid-State Sensors, Actuators and Microsystems (TRANSDUCERS)*, Denver, CO, 521-524.
- [6] M.R. Sarker, S.H.M. Ali, M. Othman, M.S. Islam. 2011. Designing a low voltage energy harvesting circuits for rectified storage voltage using vibrating piezoelectric. *IEEE Student Conf. on Research and Development (SCOREd)*, Cyberjaya, Malaysia, 343-346.
- [7] B. Yang, C. Lee, W.L. Lee, S. Lim. 2010. Hybrid energy harvester based on piezoelectric and electromagnetic mechanisms. *J. Micro/Nanolith., MEMS, and MOEMS*, 9(2) 023002.
- [8] H. Yu, J. Zhou, W. Wang. 2014. A new hybrid piezoelectric-electromagnetic micro vibration energy harvester. *IEEE Int. Conf. on Electron Devices and Solid-State Circuits (EDSSC)*, Chengdu, China, 1-2.
- [9] M.F. Ab Rahman, S.L. Kok, N.M. Ali, R.A. Hamzah, K.A.A. Aziz. 2013. Hybrid vibration energy harvester based on piezoelectric and electromagnetic transduction mechanism. *IEEE Conf. on Clean Energy and Technology (CEAT)*, 243-247.
- [10] Y. Sang, X. Huang, H. Liu, P. Jin. 2012. A vibration-based hybrid energy harvester for wireless sensor systems. *IEEE Transaction on Magnetics*, 48(11) 4495-4498.
- [11] M.R. Sarker, S.H. Md Ali, M. Othman, S. Islam. 2013. Designing a battery-less piezoelectric based energy harvesting interface circuit with 300 mV startup voltage. *J. Phys: Conf. Ser.* 431, 012025.
- [12] C. Peters, M. Ortmanns, Y. Manoli. 2007. Low power high performance voltage rectifier for autonomous microsystems. *PowerMEMS*, Freiburg, Germany, 217-220.
- [13] G.D. Szarka, B.H. Stark, S.G. Burrow. 2012. Review of power conditioning for kinetic energy harvesting systems. *IEEE Transactions on Power Electronics*, 27(2), 803-815.
- [14] U. Hasan, G. Kaveh, Z. Ozge, M. Ali, K. Haluk. 2012. A self-powered rectifier circuit for low-voltage energy harvesting applications. *International Conference on Energy Aware Computing (ICEAC)*, Guzelyurt, Cyprus, 1-5.
- [15] A.S. Herbawi, O. Paul, T. Galchev. 2013. An ultra-low-power active AC-DC CMOS converter for sub-1V integrated energy harvesting applications. *IEEE SENSORS*, Baltimore, MD. 1-4.
- [16] S. Cheng, R. Sathe, R.D. Natarajan, D.P. Arnold. 2011. A Voltage-Multiplying Self-Powered AC/DC Converter with 0.35 V Minimum Input Voltage for Energy Harvesting Applications. *IEEE Transactions on Power Electronics*, 26(9) 2542-2549.