



## A LOW COST FINGER-VEIN CAPTURING DEVICE

A. R. Syafeeza, L. H. Kwan, K. Syazana-Itqan, Hamid N.A., W. H. M. Saad and Zahariah Manap  
 Faculty of Electronics and Computer Engineering, Universiti Teknikal Malaysia Melaka, Hang Tuah Jaya, Durian Tunggal, Melaka,  
 Malaysia  
 E-Mail: [syafeeza@utem.edu.my](mailto:syafeeza@utem.edu.my)

### ABSTRACT

This paper is focusing on the development of a low cost finger-vein capturing device with Graphical User Interface (GUI). It is a device that will capture the human finger-vein image and will be used for biometric security purposes such as authentication, verification and identification. A near-infrared light (NIR) will be emitted by a bank of NIR Light Emitting Diodes (LEDs) which will penetrate the finger and are absorbed by the haemoglobin in the blood. The areas in which the NIR rays are absorbed (i.e. Veins) thus appear as dark regions in an image conveyed by a CCD camera located on the opposite side of the finger. The image captured is analyzed using Mean Square Error (MSE) and Peak Signal-to-Noise Ratio (PSNR) to determine the suitable potentiometer level and to determine the best finger-vein image.

**Keywords:** finger-vein, near-infrared, CCD, mean square error, peak signal-to-noise ratio, MATLAB.

### INTRODUCTION

Today, many biometric authentication schemes have exists. Each of them have their own limitations in which it can be either on the design of capturing device, database and traits as well as their characteristics. The fingerprint is the most popular biometrics trait being applied especially to access bank accounts. Nevertheless, it can be easily ripped off by using a fake finger. The user is also unrecognized if their fingers are injured or their fingerprints are damaged. In addition, it can be really sensitive to dirt and soaked [1]. As for facial recognition, it is sensitive to light condition, facial expression, poses, etc. Voice recognition depends on surroundings condition, exposed to noise and can be spoof using recorded voice [2].

As a consequence, by seeing all the faults mentioned above, it is important to plan a good identification system in parliamentary procedure to secure privacy, which is by using finger-vein. The primary cause is that the vein pattern lie under the skin on finger is completely special for every one of us. Its main characteristics such as universal, uniqueness and permanence are higher as compared to all the previous recognition methods [3].

However, the scanning device purposely build for research development does not exists in the market. The scanning device available (Hitachi) are integrated within a verification or identification system. Therefore, they are not suitable to be used for research and development. In fact, it is impossible for researchers to apply their own verification algorithms into it.

The finger-vein image itself has several challenges. The image captured is uneven and vary for each individual due to different thickness of the bone and skin as well as body temperature [4]. Shadows are produced when the NIR penetrates the finger. Hence, for a normal or conventional finger-vein capturing device, the quality of the finger-vein image cannot be controlled, it may appear clearer for some person or the image might have many shadows in it which make the finger-vein

pattern hard to see [5]. In addition, those finger-vein capturing devices which are already exist in the marketplace are really expensive. For instance, the cheapest finger-vein capturing device “KO-Vien2.0 Fingerprint USB Finger-vein” is more than US\$ 600 US Dollar, which is roughly RM 2220 (Ringgit Malaysia). Thus, they are not desirable for research and development purposes due to high cost.

In this paper, a low cost (RM50 - 90) finger-vein capturing device is developed using light transmission method. The device is attached with a MATLAB-based Graphical User Interface (GUI) to analyze the quality of the captured image.

### Finger-vein pattern imaging methods

There are two finger-vein pattern imaging methods which are the “light reflection” and “light transmission”. For light reflection method, the near infrared (NIR) light source and the CCD camera are positioned along the same position of the finger, the reflected light from the finger will be caught by the CCD camera. As for light transmission method, the finger will be positioned in between the NIR light source and the CCD camera, the NIR light will diffuse through the finger and caught by the CCD camera.

### Light reflection method

Light reflection method is a method where the NIR light source and the CCD camera are positioned along the same position of the finger, the reflected light from the finger will be caught by the CCD camera such as depicted in Figure-1. The vein pattern image is formed by minutiae differences of the reflected light’s intensity. After the NIR light rays are absorbed by the vein, the image shows weak light from the veins and bright light from the other parts surrounding the veins.

The major advantages of the light reflection method is the design of the device itself. The NIR illuminating source and the CCD camera are packed together to make the device more compact. The capturing



device's surface looks open for the user, and there is no blockage between the user and the device. Unfortunately, the image produced has a weak contrast, this is due to strong reflection from the skin's surface and the thin penetration of NIR light rays under the skin. Furthermore, the quality of the finger-vein pattern image is greatly affected by the unevenness and grooves on the skin's surface and thus it will interfere the verification process. This phenomenon is known as the effect of reflection [6].

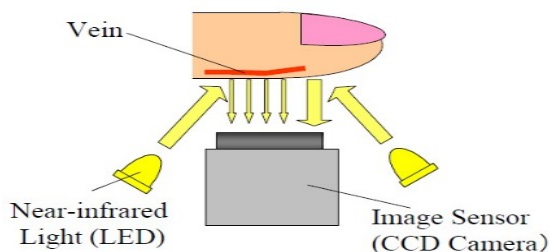

Figure-1. Light reflection method [7].

#### Light transmission method

Light transmission method is a method where the finger will be placed in between the NIR light source and the CCD camera, the NIR light will penetrate through the finger and captured by the CCD camera such as shown in Figure-2.

Since the NIR light emits from the opposite side of the finger, the NIR light will be absorbed directly by the haemoglobin in the blood, causes the vein areas where the rays are absorbed to appear as a dark area and then captured by the CCD camera. Thus, the effect of reflection does not exist and high-contrast vein pattern image can be produced [6, 8]. Due to its merits as compared to the light reflection method, light transmission is chosen to be the most suitable method used in this project.

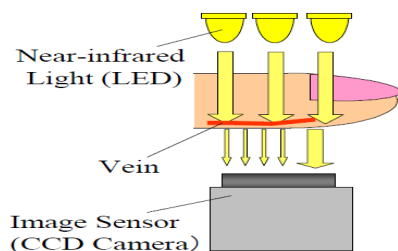

Figure-2. Light transmission method [7].

#### Cameras' image sensors

Basically, the sensors used by camera nowadays are divided into two types, which are: charge-coupled device (CCD) and complementary metal-oxide semiconductor (CMOS) image sensors. Both image sensors share the same starting point, which is both of them convert light into electric charge and process it into electronic signals.

#### Complementary Metal-oxide Semiconductor (CMOS) image sensor

Most CMOS image sensor fabrication processes are adjusted for high volume applications that only for image which is visible to human. These image sensors are not sensitive to the NIR. So, to improve the NIR sensitivity, the EPI layer thickness need to be increased. However, this will degrade the ability of the image sensor to resolve spatial features. Besides, changing the voltage or EPI doping will greatly affect the operation of the CMOS analogue and digital circuits. Therefore, CMOS image sensor is not suitable to be used in capturing NIR images.

#### Charge-Coupled Device (CCD) image sensor

In a CCD sensor, a very inadequate number of output nodes (usually just one) are used to transfer every pixel's charge to be converted to voltage, buffered, and sent to the outside world as an analogue signal. The output's uniformity (one of the important factor in image quality) is high because all the pixel can be dedicated to light capturing. The echo planar imaging (EPI) layers of CCDs can be fabricated thicker and at the same time preserving their ability to resolve fine three-dimensional (3D) features. In some NIR CCDs, the EPI is more than one hundred microns thick, compared to the five to ten microns thick EPI in most CMOS image sensors. Even though both the CCD pixel bias and EPI concentration need to be modified, but the outcome on the CCD image sensor is much easier to manage compared to CMOS. Thus, CCDs are specifically designed to be highly sensitive in the NIR compared CMOS image sensor.

Therefore, CCD image sensor type camera is chosen to be used in this project because it is specifically designed to be highly sensitive in the NIR which is suitable to capture finger-vein image where NIR imaging is applied.

#### Finger-vein capturing device

This paper mainly focuses on developing a contactless, compact and inexpensive finger-vein capturing device with GUI. The development of this project is divided into two main parts. Part A is the construction of the prototype (NIR illuminating + modified webcam). Part B is the development of GUI for the finger-vein capturing device.

#### Construction of prototype

In the construction of prototype, it is further divided into two more parts. The first part is the design, simulation, and fabrication of the NIR illuminating circuit. The circuit is based on the 555 timer, connected as a PWM generator. The discharging capacitor from pin 7 "OUT" will be used as output, which will control the base of the power transistor (2N2222). Resistor R3 & R4 are used as the protective resistors to protect both rows of the NIR LEDs. The potentiometer R2 controls the charge and discharge times, and thus the duty cycle of the PWM. In



other words, the R2 controls the brightness of the NIR LEDs.

The circuit is design and simulate by using Multisim software such as shown in Figure-3.

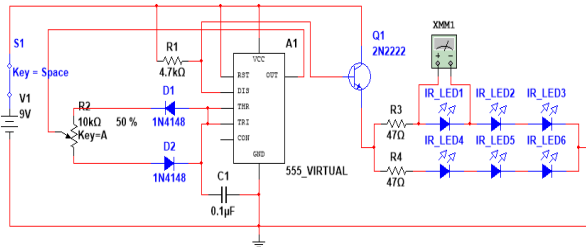

Figure-3. NIR illuminating circuit design and simulation.

Then, after simulation is successfully done, the circuit is constructed and tested by using breadboard such as shown in Figure-4.

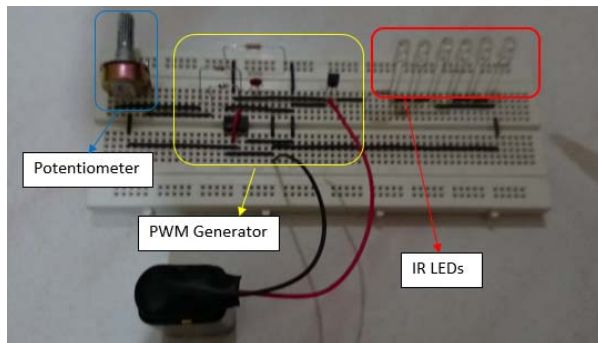

Figure-4. NIR illuminating circuit construction and testing on breadboard.

After the testing on breadboard is successful, then the whole NIR illuminating circuit is etched and fabricated into Printed Circuit Board (PCB) such as shown in Figure-5. Next, the components are soldered into the board and troubleshoot to check for any open and short circuits.

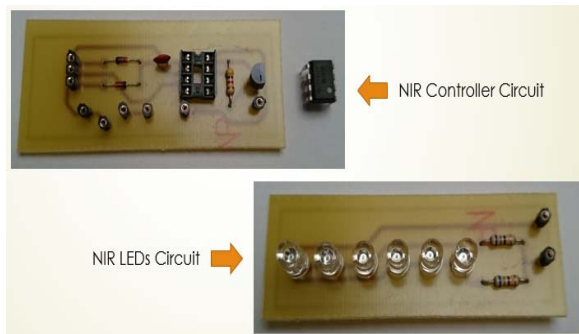

Figure-5. NIR illuminating circuit after etching and soldering.

After the whole process of design, simulation, and fabrication of NIR illuminating circuit is done, the

second part which is the modification of webcam is carried out. The webcam being proposed is the Sensonic Webcam 8000. It is chosen because its price is affordable, it has 3.1 Megapixel to produce good quality images and also easier IR filter removal. Each camera has the CCD and IR filter that block the infrared and gives natural image. So, in order to pass only infrared light and block the visible light, the IR filter from the webcam is removed and a black film which is already exposed to light is attached to the webcam.

Finally, after both parts which are the design, simulation, and fabrication of NIR illuminating circuit as well as modification of webcam are done, the prototype can be build next. The location of modified webcam as well as the NIR LEDs circuit is adjusted properly by measuring the most suitable distance so that can give better vein pattern for all types of finger. A sponge surrounded both sides of the finger was located to block external NIR light rays entering the CCD camera. Figure-6 shows the prototype of the finger-vein capturing device.



Figure-6. Finger-vein capturing device prototype.

After the prototype is done, evaluating and initial capture of the finger-vein images is done to test the functionality of the prototype. Figure-7 shows the initial finger-vein image being captured.

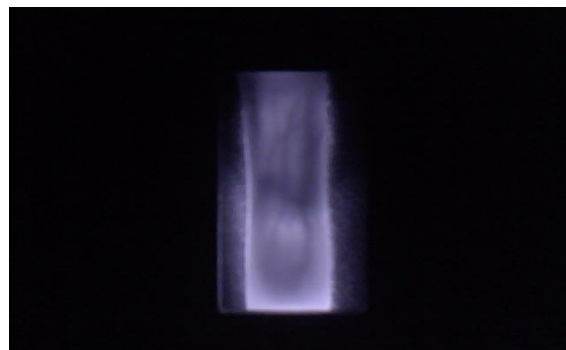

Figure-7. Evaluating and initial capture of a finger-vein image using prototype.

Development of GUI



A GUI is developed for the finger-vein capturing device by using MATLAB R2014a software. A total of six buttons, one axes, two panels and two static text boxes are created in developing the finger-vein capturing device GUI as shown in Figure-8.

The first button "Configure Cam" will provide configuration for user to set up the webcam to be used especially for laptop with default webcam in it. User is required to select the finger-vein capturing device's webcam in this configuration. The second button "Preview" will preview the live video streaming from the finger-vein capturing device's webcam, or in other words let user to preview their finger-vein. The third button "Capture Image" allow user to capture the finger-vein images and save them to their desired folder and name with the fourth button "Save Image As". The fifth button "Analyse Image" let user to analyze the captured finger-vein images of themselves to determine the standard finger-vein image which in turn determine the suitable level of the potentiometer. The last button "Find Best Image" will determine the best finger-vein image for that particular user after the finger-vein images are analyzed.

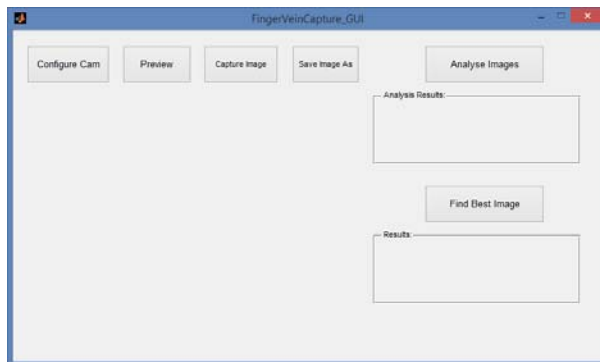

Figure-8. Finger-vein capturing device's GUI.

### Finger-vein images analysis

Two of the error metrics used to compare the quality of images are the Mean Square Error (MSE) and the Peak Signal-to-Noise Ratio (PSNR). The MSE is the cumulative squared error between the sampled images and the reference image, whereas PSNR is the measure of the peak error. The mathematical formula for the two equations are as shown in follows, Equation (1) and Equation (2):

$$MSE = \frac{1}{MN} \sum_{y=1}^M \sum_{x=1}^N [I(x, y) - I'(x, y)]^2 \quad (1)$$

$$PSNR = 20 \log_{10} \left( \frac{MaxI}{\sqrt{MSE}} \right) \quad (2)$$

where  $I(x, y)$  is the reference image,  $I'(x, y)$  is the sampled image,  $M$  and  $N$  are the dimensions of the images,  $MaxI$  is the maximum pixel of the image. Basically, the lower value of MSE indicates a lesser error the image has, and as seen from the inverse relation between the MSE and PSNR, this translates to a high value of PSNR. So, the

lower the MSE and higher the PSNR, the better the finger-vein image will be.

First of all, user have to capture ten samples of finger-vein images with ten different levels of potentiometer, which indicates ten different light intensity of the NIR. Then, a reference point between the first ten captured images is determined by finding the mean value. Next, MSE and PSNR between the reference point and the first ten captured images are determined to find "standard image" for the particular user. The images with the lowest MSE and highest PSNR will be chosen as the standard image. Figure-9 shows the first ten captured finger-vein images for USER 1. Table-1 shows the MSE and PSNR between the reference point and the first ten captured images of USER 1.

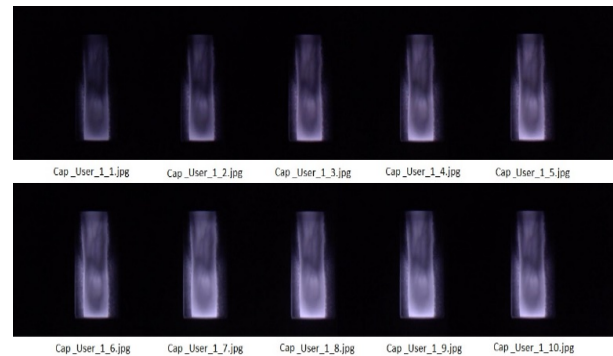

Figure-9. First ten captured finger-vein images of user 1.

Table-1. MSE and PSNR between the reference point and the first ten captured finger-vein images of USER 1.

MSE	MSE Values	PSNR	PSNR Values
1	0.0215920	1	16.6570
2	0.0105580	2	19.7640
3	0.0028151	3	25.5050
4	0.0003298	4	34.8175
5	0.0002080	5	36.8194
6	0.0013075	6	28.8354
7	0.0058136	7	22.3555
8	0.0071721	8	21.4435
9	0.0066110	9	21.7973
10	0.0028554	10	25.4433

After the reference point is determined and the standard image is known (5<sup>th</sup> Image for User 1), the potentiometer is set to that particular level (level 5 for User 1). Then, MSE and PSNR between the standard image and the second ten captured images are determined to find "best image" for the same user. Figure-10 shows the second ten captured finger-vein images for USER 1. Table-2 shows the MSE and PSNR between the standard image and the second ten captured images of USER 1.



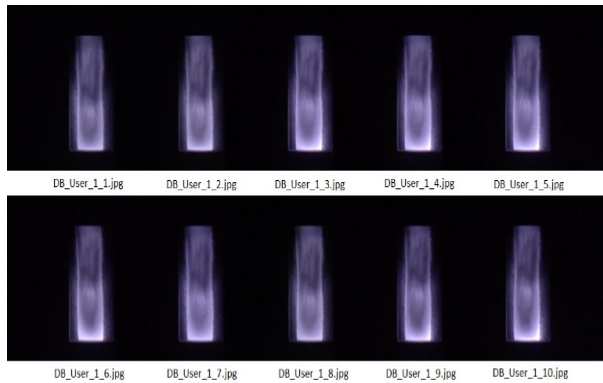
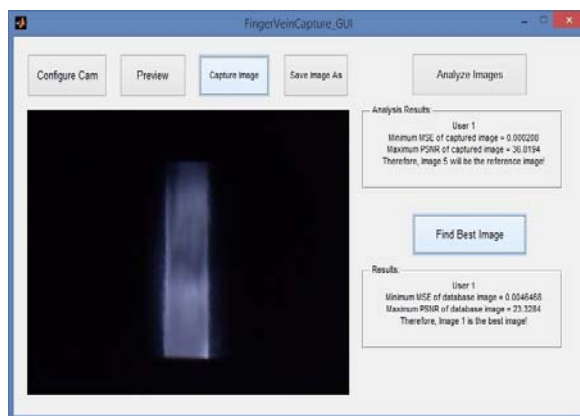

**Figure-10.** Second ten captured finger-vein images of user 1.

**Table-2.** MSE and PSNR between the standard image and the second ten captured finger-vein images of USER 1.

MSE	MSE Values	PSNR	PSNR Values
1	0.0046468	1	23.3284
2	0.0072309	2	21.4081
3	0.0156490	3	18.0553
4	0.0061242	4	22.1295
5	0.0058401	5	22.3358
6	0.0100060	6	19.9973
7	0.0073686	7	21.3261
8	0.0053408	8	22.7240
9	0.0079665	9	20.9873
10	0.0113330	10	19.4567

Lastly, the finger-vein image with the lowest MSE and the highest PSNR is the best finger-vein image for that user (1st Image for User 1 is his best finger-vein image). Figure-11 shows the analysis results displayed in the GUI.



**Figure-11.** Analysis results such as standard image and best image are shown in the GUI.

By referring to Figure-12, both the standard image and the best image with their histograms are plotted

on second figure. The histogram is labelled with the pixel count versus grey level. The reason of displaying histograms of both images is to show that this finger-vein capturing device is able to produce finger-vein image of high quality. For USER 1, the shapes of the histograms for both standard finger-vein image and best finger-vein image are almost the same even though the pixel count versus grey level is slightly different. Besides, the best finger-vein image for USER 1 is much clearer and high quality as compared to the standard finger-vein image.

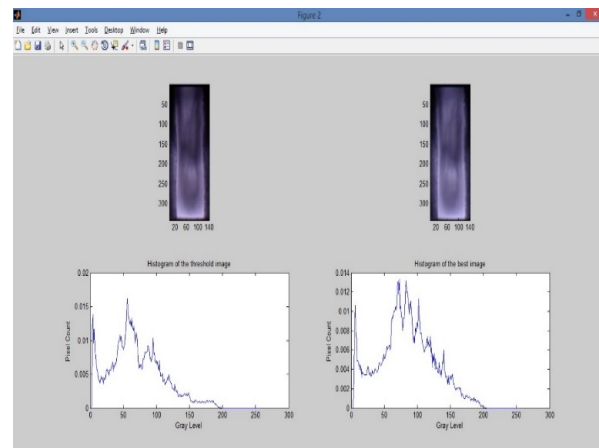

**Figure-12.** The Standard finger-vein image and the best finger-vein image together with their histograms are displayed

## CONCLUSIONS

In conclusion, a standalone finger-vein capturing device is developed. The quality of the finger-vein image could be improved by adjusting the potentiometer to a level that is suitable for that particular user. With the correct potentiometer adjustment, the NIR light intensity would be sufficient to produce a better image clarity. This is because, too bright or too dim will cause the finger-vein image to contain many shadows in it. An analysis method is developed using MATLAB R2014a to find the suitable potentiometer level for the particular user and also the best image for that user as well. Moreover, a lower cost, but efficient finger-vein capturing device is able to be developed. The cost to build the complete prototype is within the range of RM50 - 90 as compared to the device existing in the market with a minimum price of RM2220. Ultimately, a GUI is developed for the finger-vein capturing device to allow the user to configure the capturing device, previewing it, capture the finger-vein image, save the captured images to a selected directory, analyze the captured images and finally determine the best finger-vein image for the user.

## ACKNOWLEDGEMENTS

This work is supported by Universiti Teknikal Malaysia Melaka (UTeM) under the grant PJP/2014/FKEKK (5B)/S01334.

**REFERENCES**

- [1] Xuebing, W., Z. Jiangwei, and L. Xuezhang. 2010. Research on Enhancing Human Finger Vein Pattern Characteristics. Asia-Pacific Conference on Power Electronics and Design (APED).
- [2] Singh, B., N. Kapur, and P. Kaur. 2012. Speech Recognition with Hidden Markov Model: A Review. International Journal of Advanced Research in Computer Science and Software Engineering. 2(3): 400-403.
- [3] Kulkarni, S. and D.R. Raut. 2014. Finger Vein Recognition. IOSR Journal of Electrical and Electronics Engineering (IOSR-JEEE). pp. 32-36.
- [4] Valavan, M.T.T. and M.R. Kalaivani. 2014. Biometric Authentication System using Finger Vein.
- [5] Yang, J., Y. Shi, and J. Yang. 2011. Personal Identification Based on Finger-Vein Features. Computers in Human Behavior. 27(5): 1565-1570.
- [6] Edgington, B.. 2007. Introducing Hitachi's Finger Vein Technology-A White Paper. Hitachi's Finger Vein Technology.
- [7] Hashimoto, J.. Finger Vein Authentication Technology and its Future.2006. Symposium on VLSI Circuits, Digest of Technical Papers. IEEE.
- [8] Lee, E.C., H. Jung, and D. Kim. 2011. New finger Biometric Method using Near Infrared Imaging. Sensors. 11(3): 2319-2333.