

**MULTI OBJECTIVE OPTIMIZATION USING NON-  
DOMINATED SORTING APPROACH FOR LOAD  
FREQUENCY CONTROL**

**SAIFULLAH BIN SALAM**

**FACULTY OF ENGINEERING  
UNIVERSITY OF MALAYA  
KUALA LUMPUR**

**2016**

**MULTI OBJECTIVE OPTIMIZATION USING NON-  
DOMINATED SORTING APPROACH FOR LOAD  
FREQUENCY CONTROL**

**SAIFULLAH BIN SALAM**

**RESEACRH REPORT SUBMITTED IN PARTIAL  
FULFILMENT OF THE REQUIREMENTS FOR THE  
DEGREE OF MASTER OF ENGINEERING  
(INDUSTRIAL ELECTRONIC AND CONTROL)**

**FACULTY OF ENGINEERING  
UNIVERSITY OF MALAYA  
KUALA LUMPUR**

**2016**

**UNIVERSITY OF MALAYA  
ORIGINAL LITERARY WORK DECLARATION**

Name of Candidate: **SAIFULLAH BIN SALAM**

(I.C/Passport No: **800907-13-5049**)

Registration/Matric No: **KGK 140003**

Name of Degree: **MASTER OF ENGINEERING (INDUSTRIAL ELECTRONIC AND CONTROL)**

Title of Project Paper/Research Report/Dissertation/Thesis (“this Work”):

**MULTI OBJECTIVE OPTIMIZATION USING NON-DOMINATED SORTING APPROACH FOR LOAD FREQUENCY CONTROL**

Field of Study: **POWER CONTROL**

I do solemnly and sincerely declare that:

- (1) I am the sole author/writer of this Work;
- (2) This Work is original;
- (3) Any use of any work in which copyright exists was done by way of fair dealing and for permitted purposes and any excerpt or extract from, or reference to or reproduction of any copyright work has been disclosed expressly and sufficiently and the title of the Work and its authorship have been acknowledged in this Work;
- (4) I do not have any actual knowledge nor do I ought reasonably to know that the making of this work constitutes an infringement of any copyright work;
- (5) I hereby assign all and every rights in the copyright to this Work to the University of Malaya (“UM”), who henceforth shall be owner of the copyright in this Work and that any reproduction or use in any form or by any means whatsoever is prohibited without the written consent of UM having been first had and obtained;
- (6) I am fully aware that if in the course of making this Work I have infringed any copyright whether intentionally or otherwise, I may be subject to legal action or any other action as may be determined by UM.

Candidate’s Signature

Date:

Subscribed and solemnly declared before,

Witness’s Signature

Date:

Name:

Designation:

## ABSTRACT

This work provides an in-depth analysis on the implementation of multi objective optimization based on non-dominated sorting for load frequency control by using proportional-integral-derivative (PID) controller for interconnected reheat thermal power system. The load frequency control is use to control the frequency and inter-area (tie line) oscillation. When the load demand slightly changes, the frequency of the system will be affected and the control action need be react as soon as possible to prevent system instability. The real power is related with frequency which will slightly change due to any changing in frequency. The two area power system model will be considered in this investigation. The optimization technique which has been implemented is the Evolutionary Programming (EP). The weighted sum approach of EP is considered in order to provide multiple solution point by varying the weighted. The non-dominated point has been selected to optimize the PID gains to provide least overshoot value and fast frequency response of the system. Two objectives function will be considered for this investigation and has been characterized by the performance criterions which are Integral of Time Multiplied Absolute Error (ITAE) and Integral of Time Weighted Squared Error (ITSE). Optimum PID parameters which able to provide the best performance in terms of lower settling time and less overshoot value in the frequency deviation response will be determined.

## ABSTRAK

Kerja penyelidikan ini merangkumi analisis yang mendalam mengenai mengoptimumkan berbilang objektif berdasarkan kepada susunan tidak perusa bagi beban kawalan frekuensi dengan menggunakan kawalan PID untuk dua kawasan pemanasan semula haba tersaling hubung di rangkaian sistem kuasa. Beban kawalan frekuensi digunakan untuk mengawal frekuensi dan ayunan talian pengikat. Apabila beban penjana berubah sedikit, frekuensi system juga akan terkesan dan kawan perlu bertindak seberapa segera untuk mengelakkan system dari tidak stabil. Kuasa sebenar juga berhubung kait dengan frekuensi di mana akan berubah jika frekuensi berubah. Dua kawasan tersaling hubung akan dianalisis. Kaedah yang diaplikasi adalah kaedah Evolutionary Programming. Pendekatan jumlah pemberat dalam Evolutionary Programming dipertimbangkan untuk mendapatkan pelbagai penyelesaian dengan menaikkan pemberat. Susunan tidak perusa dipilih untuk mengoptimumkan gandaan PID bagi menghasilkan maksima terlajak yang kurang dan respon frekuensi yang cepat. Dua fungsi objektif dipertimbangkan untuk dua kawasan pemanasan semula haba tersaling hubung dan dicirikan oleh kriteria prestasi iaitu ITAE dan ITSE. Parameter PID yang optima menghasilkan prestasi yang terbaik dari segi masa penganapan yang rendah dan kurang nilai lajukan dalam respon frekuensi.

## ACKNOWLEDGEMENTS

Alhamdulillah praise to Allah for His love and merciful, I had completed the research project as the partial fulfilment of the requirement for the Master of Engineering (Industrial Electronic and Control) in University of Malaya, Kuala Lumpur. I wish to express my great appreciation to my supervisor, Assoc. Prof. DR. Hazli Mokhlis for his excellent supervision and guidance from zero until the project completed. He also acted as a mentor in order to provide me to be good researcher in term of literature review, collecting and analysed data and thesis writing. His great experience and knowledge in power system contributed good value in my research work. Special thanks to DR. Kanendra Naidu for his guidance and support in this area research work.

I am extremely thankful to my mother Zainon bin Hassan and my wife Nurul Aini binti Ghazali for their continuous encouragement and prayer throughout my research period.

My great thanks to all University of Malaya staff's for their kind help. Finally I take this opportunity to express my thanks and gratitude to all my friends Nur Irwani, Mohd Zamri and Meor for their support.

## TABLE OF CONTENTS

Abstract .....	iii
Abstrak .....	iv
Acknowledgements .....	v
Table of Contents .....	vi
List of Figures .....	viii
List of Tables.....	x
<b>CHAPTER 1: INTRODUCTION.....</b>	<b>1</b>
1.1 Overview.....	1
1.2 Problem Statement.....	2
1.3 Research Objective .....	2
1.4 Methodology of Project .....	3
1.5 Overall Research Report.....	3
<b>CHAPTER 2: LITERATURE REVIEW.....</b>	<b>5</b>
2.1 Introduction.....	5
2.2 Basic Generator Control Loops .....	6
2.3 Load Frequency Control .....	7
2.3.1 Generator Model.....	8
2.3.2 Load Model .....	9
2.3.3 Prime Mover Model .....	10
2.3.4 Governor Model .....	11
2.4 Optimization Technique .....	12
2.4.1 Evolutionary Programming (EP).....	14
2.4.2 Single objective optimization.....	14

2.4.3	Multi-objective optimization.....	16
2.4.4	Non-dominated Set.....	17
<b>CHAPTER 3: METHODOLOGY .....</b>		<b>19</b>
3.1	Evolutionary Programming Design .....	19
3.2	Load Frequency Control Modeling .....	26
3.2.1	Modeling for single area system .....	26
3.2.2	Modeling for two area system.....	27
<b>CHAPTER 4: SIMULATION RESULTS .....</b>		<b>30</b>
4.1	Introduction.....	30
4.2	System Parameters.....	30
4.3	System Testing.....	31
<b>CHAPTER 5: CONCLUSION AND FUTURE WORK .....</b>		<b>54</b>
5.1	Conclusion .....	54
5.2	Future work.....	55
	References .....	56



## LIST OF FIGURES

Figure 2.1	LFC and AVR schematic diagram in synchronous generator .....	6
Figure 2.2	Generator and load block diagram .....	10
Figure 2.3	Block diagram for simple turbine.....	10
Figure 2.4	Block diagram for governing system speed .....	11
Figure 2.5	Block diagram of load frequency control.....	12
Figure 2.6	Optimization Technique Categories .....	13
Figure 2.7	Evolutionary Programming Flow Chart .....	15
Figure 2.8	Distance and energy bi-objective optimization .....	17
Figure 2.9	Pareto optimal solutions .....	18
Figure 2.10	Solutions set of S and the non-dominated points .....	18
Figure 3.1	Graph objective 2 vs objective 1 for each run times .....	24
Figure 3.2	Graph of pareto point for objective 2 vs objective 1 .....	25
Figure 3.3	90° span of lines for Pareto front line.....	25
Figure 3.4	Load Frequency Control for Single Area System .....	26
Figure 3.5	Two Areas System of Load Frequency Control .....	29
Figure 4.1	Pareto point for weighted of $w_1=1.0$ and $w_2=0.0$ .....	32
Figure 4.2	Pareto point for weighted of $w_1=0.9$ and $w_2=0.1$ .....	33
Figure 4.3	Pareto point for weighted of $w_1=0.8$ and $w_2=0.2$ .....	34
Figure 4.4	Pareto point for weighted of $w_1=0.7$ and $w_2=0.3$ .....	35
Figure 4.5	Pareto point for weighted of $w_1=0.6$ and $w_2=0.4$ .....	36
Figure 4.6	Pareto point for weighted of $w_1=0.5$ and $w_2=0.5$ .....	37
Figure 4.7	Pareto point for weighted of $w_1=0.4$ and $w_2=0.6$ .....	38
Figure 4.8	Pareto point for weighted of $w_1=0.3$ and $w_2=0.7$ .....	39

Figure 4.9	Pareto point for weighted of $w_1=0.2$ and $w_2=0.8$ .....	40
Figure 4.10	Pareto point for weighted of $w_1=0.1$ and $w_2=0.9$ .....	41
Figure 4.11	Pareto point for weighted of $w_1=0.0$ and $w_2=1.0$ .....	42
Figure 4.12	Non-dominated point for load frequency control.....	43
Figure 4.13	Frequency response for point 1 .....	44
Figure 4.14	Frequency response for point 2 .....	45
Figure 4.15	Frequency response for point 3 .....	45
Figure 4.16	Frequency response for point 4 .....	46
Figure 4.17	Frequency response for point 5 .....	46
Figure 4.18	Frequency response for point 6 .....	47
Figure 4.19	Frequency response for point 7 .....	47
Figure 4.20	Frequency response for point 8 .....	48
Figure 4.21	Frequency response for point 9 .....	48
Figure 4.22	Frequency response for point 10 .....	49
Figure 4.23	Frequency response for point 11 .....	49
Figure 4.24	Frequency response for point 12 .....	50

## LIST OF TABLES

Table 3.1	The best objective functions value for each weighted sum.....	22
Table 4.1	System Parameter for Load Frequency Control .....	31
Table 4.2	Value of $z_1$ and $z_2$ for weighted set of $w_1=1.0$ and $w_2=0.0$ .....	32
Table 4.3	Value of $y_1$ and $y_2$ for weighted set of $w_1=0.9$ and $w_2=0.1$ .....	33
Table 4.4	Value of $z_1$ and $z_2$ for weighted set of $w_1=0.8$ and $w_2=0.2$ .....	34
Table 4.5	Value of $z_1$ and $z_2$ for weighted set of $w_1=0.7$ and $w_2=0.3$ .....	35
Table 4.6	Value of $z_1$ and $z_2$ for weighted set of $w_1=0.6$ and $w_2=0.4$ .....	36
Table 4.7	Value of $z_1$ and $z_2$ for weighted set of $w_1=0.5$ and $w_2=0.5$ .....	37
Table 4.8	Value of $z_1$ and $z_2$ for weighted set of $w_1=0.4$ and $w_2=0.6$ .....	38
Table 4.9	Value of $z_1$ and $z_2$ for weighted set of $w_1=0.3$ and $w_2=0.7$ .....	39
Table 4.10	Value of $z_1$ and $z_2$ for weighted set of $w_1=0.2$ and $w_2=0.8$ .....	40
Table 4.11	Value of $z_1$ and $z_2$ for weighted set of $w_1=0.1$ and $w_2=0.9$ .....	41
Table 4.12	Value of $z_1$ and $z_2$ for weighted set of $w_1=0.0$ and $w_2=1.0$ .....	42
Table 4.13	Optimized PID Parameter for non-dominated points .....	44
Table 4.14	Settling time and maximum overshoot for optimized PID parameters ....	51
Table 4.15	System performance of dominated points for area 1 .....	52
Table 4.16	System performance of dominated points for area 2.....	52

## CHAPTER 1: INTRODUCTION

### 1.1 Overview

In the late 18<sup>th</sup> century, electrical power distribution becomes necessary when the electrical is generated at the power station. Before the existence of power station, the electrical energy is generated at the place where the electrical power is needed. European and United States were the first cities where the electrical distribution system started to supply the electricity to lightings in the cities. The electrical power system can be divided into several categories which are generation, transmission, distribution and utilization of electrical energy which are used to supply energy to the consumers continuously with good quality and high level of reliability.

The important factor that needs to be considered in interconnected power system is the ability to supply the consumers with proper interaction between generating, transmitting and distributing elements and the stability of the interconnected power system. The stability is an important factor need to be highly observed and when the interconnected power system is operated in normal operation and when there is change in load demand. The imbalance between generation and load must be resolved as soon possible to avoid frequency deviation from the nominal value which can cause further damages to the system.

## **1.2 Problem Statement**

In thermal power system, because of load changes in the consumer side, the frequency varies dynamically. Similarly, maintaining the nominal generator output parameters is one of the necessary conditions to obtain optimal system performance. In order to preserve the stability of the system, the generator should be able to settle the deviation in frequency with less settling time and low overshoot value. The controller is required to act as fast as possible for any changes in frequency to maintain the frequency within the specific limit. In regards to this, a multi-objective optimization technique which is able to provide the optimum PID parameters to achieve both these objective is required.

The non-dominated sorting approach is investigated to obtain the optimum parameters value for PID controller in order to achieve the best performance for frequency response in terms of settling time and least maximum overshoot.

## **1.3 Research Objective**

The objectives of this research project are:

1. To model the two-area interconnected reheat thermal power system.
2. To propose multi-objective optimization based on non-dominated sorting technique for PID parameters of load frequency control.
3. To determine PID parameters based on minimum settling time and overshoot using proposed optimization technique.

## **1.4 Methodology of Project**

This project contains several work scopes to complete the investigation and achieve the result. The work scope to be carried out as follows:

- To model the load the frequency control for single area system and two areas system interconnected reheat thermal system in power system generator.
- To implement the evolutionary programming optimization technique by using non-dominated sorting approach.
- To model the two areas interconnected reheat thermal system in MATLAB Simulink with the PID controller based on mathematical modeling to the system.
- To design the algorithm of evolutionary programming based optimization technique for two objectives functions and integrates with the PID controller of the LFC.
- To carry out the simulation process to obtain the non-dominated pareto point to evaluate the system performance.

## **1.5 Overall Research Report**

This research study contains five chapters. In the first chapter, the power system overview which describes the general information related power system generation is presented. This is follow by the problem statement that is faced in power system generation. From the problem statement, the objective of the research is formulated as means of solution. In order to describe the research objective, research methodology is introduced to find the proper method to describe the overall work scope.

The second chapter contains literature review regarding load frequency control for single area system and two areas interconnected reheat thermal system research. Also related optimization method for load frequency control that is used in the LFC research is reviewed.

The third chapter describes the research methodology based on the problem statement. The evolutionary programming algorithm is introduced and tested for multi-objective functions (dual objective) for different mathematical equations. The load frequency control is designed for two area interconnected reheat thermal system.

Chapter four contains the results of the optimization process which is to obtain the non-dominated points from the graph. Then the non-dominated points, optimized parameter for PID is obtained and further evaluated. The results are presented in tables and figures.

Chapter five contains the conclusion of the study and the future work of the research.

## CHAPTER 2: LITERATURE REVIEW

### 2.1 Introduction

The real power and active power are two important elements in power system. Real power is related to system frequency whereas the active power is related to voltage magnitude and it is less sensitive to frequency. The active power and reactive power are controlled separately for proper control and stability. The frequency of the system is affected if the real power is varies while variation in voltage magnitude is due to changes in reactive power in the system. Thus, load frequency control is introduced in order to control frequency via active power control against any load changes.

Load frequency control in interconnected power system is used to restore the system frequency if there are any load changes and maintain the tie-line power flow to a specified value. Tie-line is the transmission lines that are connected between areas in different geographical location. Through this tie-line, the power will be shared between different locations/regions. Imbalance between load demand and generation will cause the system frequency to be affected where the frequency will decrease if the load demand is greater than the power generated. The changes in the load demand is uncontrollable due to it being on the consumer side but the imbalance between load demand and power generated can be rectified as soon as possible by controlling the governor speed on the generator side.



## 2.2 Basic Generator Control Loops

Load frequency control (LFC) and automatic voltage regulator (AVR) are two common equipment that are installed in generator in the interconnected reheat thermal system as shown in Figure 2.1. The general diagram of load frequency control and automatic voltage regulator of a synchronous generator consists of a frequency sensor and a voltage sensor to detect any small changes in frequency and voltage in load demand. Both these sensors will produce the signal to the controller which is the load frequency control and automatic voltage regulator to react as soon as possible to maintain the frequency and the voltage magnitude within a specific limit. Small changes related to rotor angle,  $\delta$  due to changes in speed of generator and frequency will affect the real power generated.

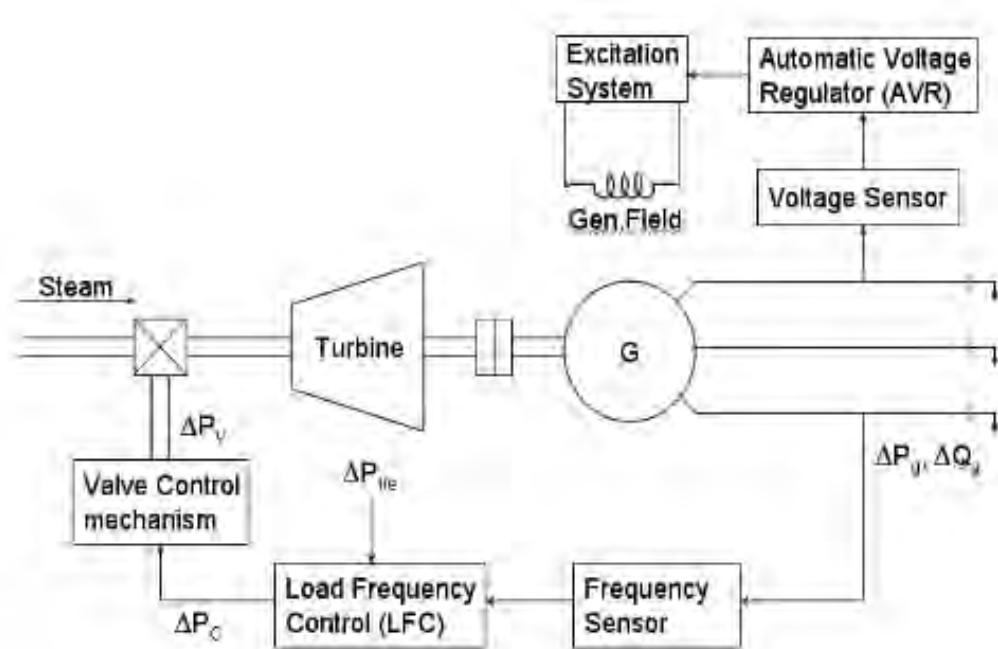

Figure 2.1 LFC and AVR schematic diagram in synchronous generator

### 2.3 Load Frequency Control

Load frequency control is one of the most important elements in the power system to maintain the frequency and tie-line power flow at the nominal value. There is voluminous work for load frequency control carried out by researchers to achieve the best method to maintain the frequency and tie-line interchange between the areas at rated value. The most extensively used controls in the industry are based on classical PI or PID controller. However, this classical technique have disadvantage such as the undesirable speed overshoot and the slow response due to sudden load disturbance (Boumediene & Ezzouar, 2002). The voluminous work for load frequency control including the control strategies and intelligent technique has been applied to solve the frequency regulation problem. Comparative study between PI, optimal and fuzzy controller shows optimal and fuzzy controller technique for single area system of load frequency control has obtain good performances of frequency response. However, the optimal technique highly depends on choices of the weighting matrices. The fuzzy controller depends on the expert knowledge to choosing the rule base (Ndubisi, 2011). Multi area system based on fuzzy controller has obtain good performance compare to Particle Swarm Optimization (PSO) and classical Ziegler-Nichols (Z-N) method (Nour El Yakine Kouba, Mena, Hasni, & Boudour, 2015). Artificial bee colony optimization has been applied to obtain the optimal value of the PID controller parameters based load frequency control for single area system and multi-area system (N.E.Y. Kouba, Mena, Hasni, & Boudour, 2015). The area control error (ACE) is the input signal of the controllers and has been measured in order to satisfy the load frequency control objectives which is the parameters tuning are selected depending on the control area characteristics (Boumediene & Ezzouar, 2002).

Small changes in rotor angle  $\delta$  will affect the frequency and tie-line real power which is measured as error  $\Delta\delta$ . Prime mover is the controllable part which controls the torque due to error signal in frequency,  $\Delta f$  and  $\Delta P_{tie}$ . Prime mover receives real power signal  $\Delta P_v$  either to increase or decrease the torque in order to bring back the  $\Delta f$  and  $\Delta P_{tie}$  to the specified range by changing the generator's output,  $\Delta P_g$ .

In order to design and analyze the control system, mathematical modelling of the system should be derived in which in the form of transfer function or state variable. Both methods need the system to be linearized for generator model, load model, prime mover model and governor model (Hadi 1999).

### 2.3.1 Generator Model

The generator is a system which convert mechanical power to electrical power by using the turbine (Nour El Yakine Kouba et al., 2015). The generator model equation is described from the swing equation of a synchronous machine and can be given by:

$$\frac{2H}{W_s} \frac{d^2 \Delta\delta}{dt^2} = \Delta\rho_m - \Delta\rho_e \quad (2.1)$$

where:

- H: inertia constant in per unit
- $W_s$  is electrical angular velocity
- $\rho_m$  is mechanical power
- $\rho_e$  is electrical power

It can also be written in terms of small deviation in speed without explicit per unit notation as follows:

$$\frac{d\Delta\omega}{dt} = \frac{1}{2H}(\Delta\rho_m - \Delta\rho_e) \quad (2.2)$$

Equation (2.2) is transformed into Laplace transform as follows:

$$\Delta\Omega(s) = \frac{1}{2Hs}[\Delta\rho_m(s) - \Delta\rho_e(s)] \quad (2.3)$$

### 2.3.2 Load Model

In power system, the load can be divided into two categories which are loads with resistive element and loads with inductive element. The inductive loads such motor load can affect the frequency due to their sensitivity with changes in frequency. The speed load characteristic is an important element to show the sensitivity of inductive load to changes in the frequency. This relationship of load speed characteristic can be expressed as:

$$\Delta P_e = \Delta P_L + D\Delta\omega \quad (2.4)$$

- $\Delta P_L$ : load changes sensitivity without frequency affect
- $\Delta\omega$ : load changes sensitivity with frequency affect
- D: load changing divided by frequency changing in percentage

By combining generator model in the equation, resultant in the block diagram in shown Figure 2.2.

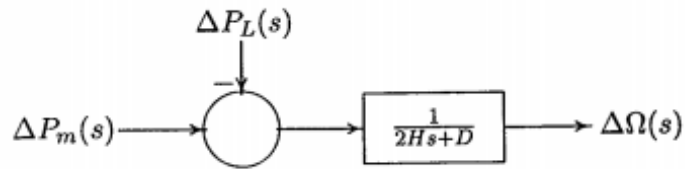

Figure 2.2 Generator and load block diagram

### 2.3.3 Prime Mover Model

The energy from electricity, turbine or pressure sources can be transformed into mechanical energy in order to create source of power. This type of power source can be defined as prime mover. In industrial power generator, the principle energy source is coming from steam turbine plant, the diesel piston engine and the gasoline piston engine. For principle of steam turbine plant, the changes of mechanical output power  $\Delta P_m$  are related to changes in steam valve position  $\Delta P_v$  and can be given by:

$$G_T(s) = \frac{\Delta P_m(s)}{\Delta P_v(s)} = \frac{1}{1 + \tau_T s} \quad (2.5)$$

which  $\tau_T s$  is prime mover time constant.

From equation (2.5), the block diagram for simple turbine is as shown in Figure 2.3.

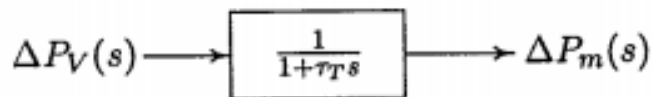

Figure 2.3 Block diagram for simple turbine

### 2.3.4 Governor Model

In order to model load frequency control, governor model is one of important part that has to be designed and modeled. Basically the governor model has two inputs which are changes in frequency and speed changer's position. Most the governor nowadays uses electronic device to sense the frequency and speed changes. When the speed changes, the turbine input valve will be adjusted to change the speed to a new value by changing the mechanical power output. This new steady state speed characteristic is given by:

$$\Delta P_g(s) = \Delta P_{ref}(s) - \frac{1}{R} \Delta \Omega(s) \quad (2.6)$$

R is given by  $\frac{\Delta \omega}{\Delta P}$  and  $\Delta P_{ref}$  is reference set power.

By assuming the linear relationship between  $\Delta P_g$  and  $\Delta P_V$ , we have equation (2.7).

$$\Delta P_V(s) = \frac{1}{1 + \tau_g s} \Delta P_g(s) \quad (2.7)$$

These two equations (2.6) and (2.7) can be represented in block diagram as shown in Figure 2.4

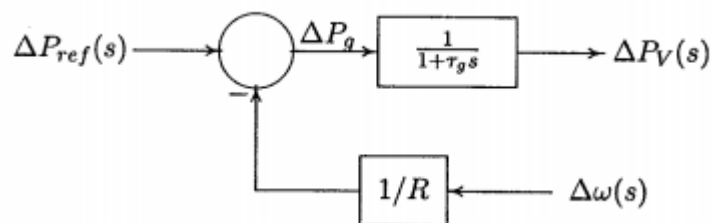

Figure 2.4 Block diagram for governing system speed

Then, by combining all block diagram in Figure 2.2, Figure 2.3 and Figure 2.4, will represented the block diagram of load frequency control as shown in Figure 2.5.

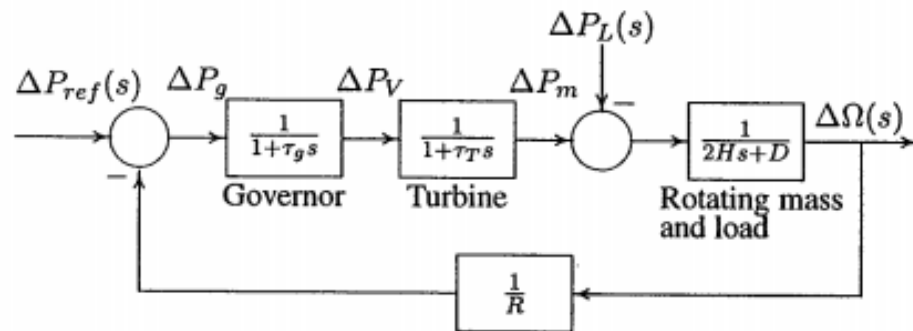

Figure 2.5 Block diagram of load frequency control

## 2.4 Optimization Technique

Optimization is one of the mathematical disciplines which find the maximum or minimum value of a function by choosing optimum the input values. There are many optimization technique which have been implemented to achieve the best performance for power system controller (Kothari, 2012) as shown in Figure 2.6. Basically, optimization is the method to find best value of some objective function.

Evolutionary computation is a type of algorithm which is a subfield of artificial intelligence. This algorithm also called as evolutionary algorithm and is used for optimization process through evolutionary process which is needs to develop the programming codes. Basically through this method, development of population is created by iterative process and evolves new population information in order to select the best population by using population based approach. The best population is selected by randomly search to achieve the main objective. There are reasons the evolutionary optimization become popularity that is the evolutionary optimization no need derivative information. This technique also relatively simple to implement and another reason is

the evolutionary optimization is flexible and have a wide-spread applicability (Deb, 2011). Evolutionary computation is divided into 4 types that are evolutionary programming (EP), Evolutionary Strategy (ES), genetic programming (GP) and generic algorithm (GA) (Abdul Aziz, Sulaiman, Musirin, & Shaari, 2013). The application of evolutionary algorithm including to minimize transmission losses in power system, maximize profit business, maximize car performance, maximize fuel consumption and minimize generation cost in power station.

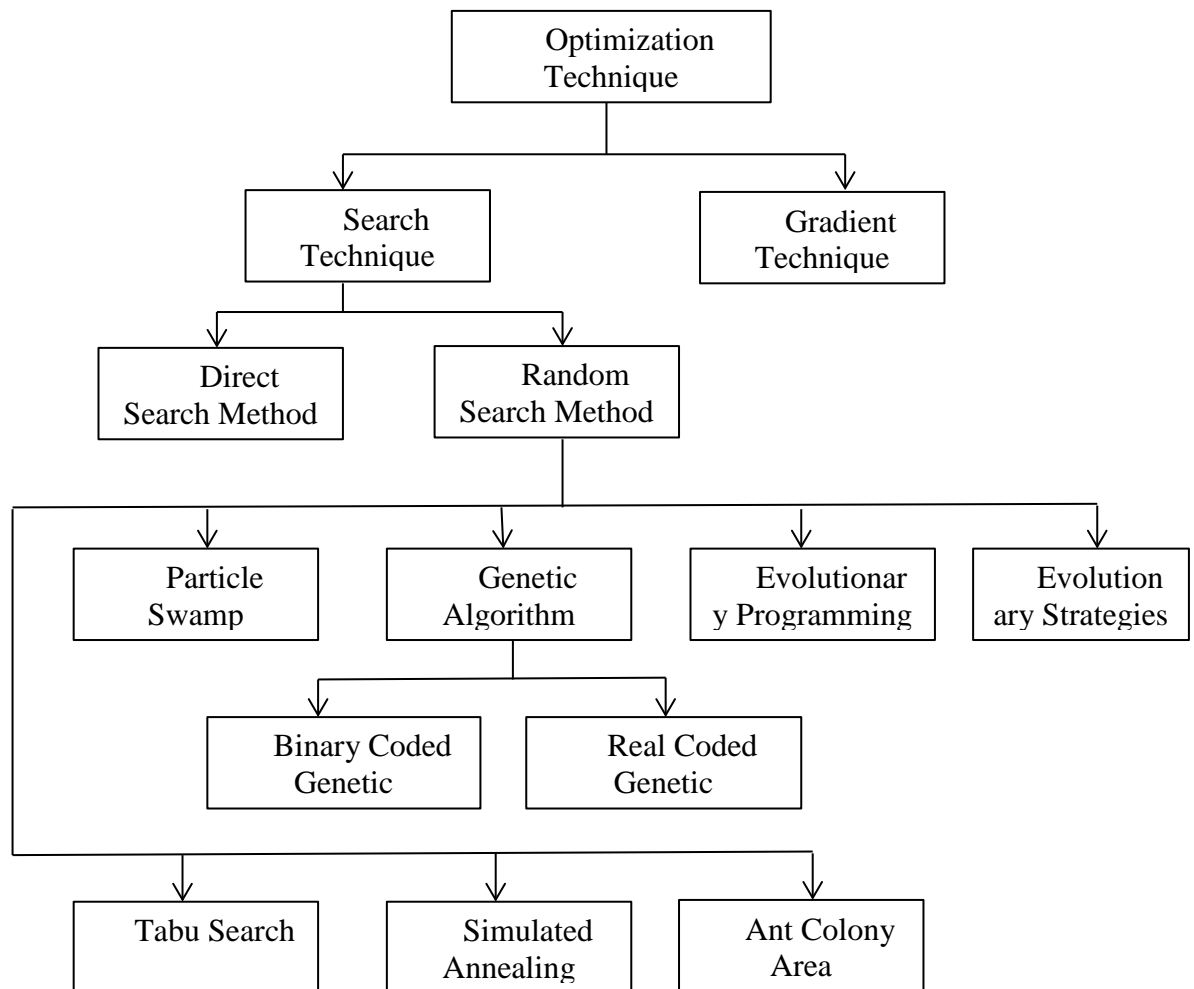

Figure 2.6 Optimization Technique Categories