



# FATIGUE DAMAGE ANALYSIS OF AUTOMOBILE STEERING KNUCKLE USING FINITE ELEMENT ANALYSIS

K. A. Zakaria<sup>1</sup>, F. H. A. Suhadak<sup>1</sup>, A. E. M. Razalli<sup>1</sup> and M. S. Kassim<sup>2</sup>

<sup>1</sup>Faculty of Mechanical Engineering, Universiti Teknikal Malaysia Melaka, Durian Tunggal, Melaka, Malaysia

<sup>2</sup>Faculty of Manufacturing, Universiti Teknikal Malaysia Melaka, Durian Tunggal, Melaka, Malaysia

E-Mail: [kamarul@utem.edu.my](mailto:kamarul@utem.edu.my)

## ABSTRACT

Fatigue failure may occur in any engineering component subjected under cyclic loading that is lower than the ultimate strength of the material. However, fatigue tests are costly because they require much time just for a single experiment. Hence, simulation using finite element analysis (FEA) can reduce the cost and time for experiment. This paper presents the stress analysis and fatigue damage of steering knuckle using FEA. Steering knuckle is a vital part of the steering system, where the knuckle will pivot the wheels to turn; the steering knuckle is also connected to the suspension system. FEA was performed on a steering knuckle using a commercial finite element package. The steering knuckle is modelled based on 1300 cc national automobile, and grey cast iron with compressive strength of 572 MPa and tensile strength of 152 MPa is used as a material of the steering knuckle. The steering knuckle is subjected to three types of load according to a reported procedure. The critical part of the steering knuckle can be identified in the stress analysis. The relationship among the force applied, maximum displacement, damage, and factor safety is also determined. Moreover, a relationship can be obtained between the fatigue damage and applied loads of the steering knuckle.

**Keywords:** damage, fatigue, finite element analysis, steering knuckle.

## INTRODUCTION

Steering knuckle is a joint that allows the steering arm to pivot the front wheels. The forces exerted on this assembly are of cyclic nature as the steering arm is turned to manoeuvre the vehicle to the left or to the right and back to the centre [1]. Thus, the steering knuckle is a vital part of the steering system [2]. The steering knuckle contains wheel hubs or spindles and is attached to the suspension components of a vehicle. These components are critical to the front and rear suspension safety [3].

The current steering knuckle design is normally designed based on static analysis. The steering knuckle has been subjected under complex types of load, namely, static, dynamics and fatigue aspects [4]. Fatigue is responsible for 85%-90% of all structural failures [5]. The result of this study may be used as a basis in designing a good, reliable, and effective steering knuckle.

Azrulhisham *et al.* evaluated the fatigue life reliability of knuckle in a steering system of a passenger car [6]. A Pearson system was designed to assess the estimated fatigue life reliability by considering the material property variations. Considering that random loads are applied on steering knuckle, the shortest life appears in the vertical load direction, whereas the lowest fatigue life reliability is found between 14000-16000 cycles [6].

Babu *et al.* [2] examined the design and production of a steering knuckle to enhance its

performance. This research was conducted through steering knuckle modelling and analysis to determine the minimum stress area on steering knuckle. The maximum stress concentration is caused by the load exerted on steering knuckle.

Currently, the automotive industry in Malaysia is highly dependent on foreign technology. The steering knuckle, which is a vital component of a car, is mostly designed and imported from foreign countries [7]. Given that research on steering knuckle is crucial for the development in the automotive industry, studies on steering knuckle is important to provide an overview of stress distribution, leading to the better understanding of the existing knuckle design.

Thus, this paper attempts to extensively investigate the relationship among force, displacement maximum, and factor safety static analysis of steering knuckle and determine the part of a steering knuckle that is prone to damage.

## METHODOLOGY

This study models the steering knuckle of a 1300 cc national car, and the material used for the steering knuckle is ASTM 20 standard gray cast iron [3]. Tables 1 and 2 show the typical chemical composition and mechanical properties of the grey cast iron [8], respectively.

**Table-1.** Typical chemical composition of the steering knuckle.

Component element properties	Carbon, C	Chromium, Cr	Copper, Cu	Molybdenum, Mo	Nickel, Ni	Phosphorous, P	Silicon, Si	Sulfur, S
Percentage (%)	3.25-3.5	0.050-0.45	0.15-0.4	0.50-0.90	0.050-0.10	≤0.12	1.8-2.3	≤0.15



**Table-2.** Mechanical properties of the steering knuckle.

Name	Grey cast iron (SN)
Tensile Strength	151 MPa
Compressive Strength	572 MPa
Elastic Modulus	66.17 GPa
Poissons's Ratio	0.27
Mass Density	7200 kg/ m <sup>3</sup>

Digital calliper, protractor, and 3D scanner are used to determine the dimensions of the steering knuckle. The steering knuckle is first sprayed white and a sticker is subsequently applied on it. The image obtained using the 3D scanning method is saved as STL or IGES file and then converted into a 3D model using computer-aided design (CAD) software (Figure-1).

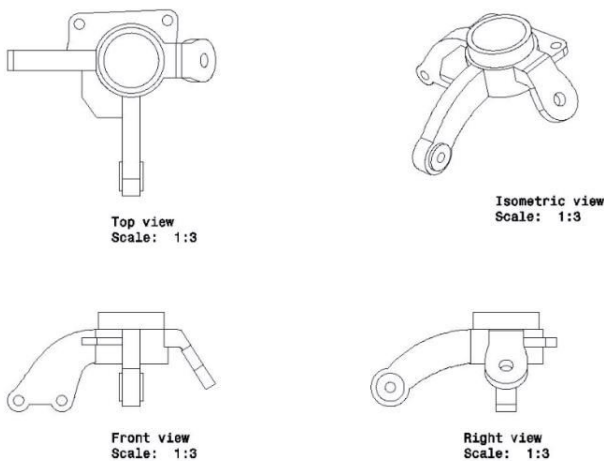
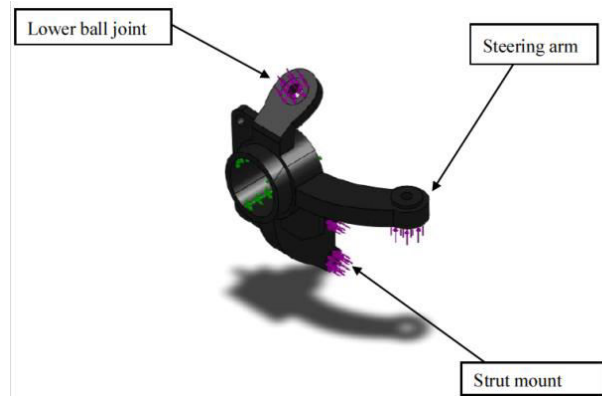

**Figure-1.** 3D modelling of the steering knuckle using CAD.

Finite element analysis (FEA) is employed to investigate the fatigue and static aspects of the steering knuckle. The force applied on the steering knuckle is based on previous study done by Shazwan [3], who analyzed the steering knuckle of a Toyota Camry driven on uneven road. Force is applied on the three parts of the steering knuckle, namely, the strut mount (SM), lower ball joint (LB), and steering arm (SA). Table-3 and Figure-2 show the magnitude of the applied force and their location, respectively. Table-4 shows the meshing properties of the FEA model.

**Table-3.** Magnitude of applied force acting on steering knuckle.

No. of test	Force applied (N)		
	Strut mount	Lower ball joint	Steering arm
1	1500	1000	1000
2	1600	1066.7	1066.7
3	1700	1133.3	1133.3
4	1800	1200	1200
5	1900	1266.7	1266.7



**Figure-2.** Location of forces acting on steering knuckle.

**Table-4.** Meshing properties of FEA model.

Mesh type	Solid mesh
Mesher Used	Standard Mesh
Automatic Transition	Off
Include Mesh Auto loops	Off
Jacobian Points	4 Points

**RESULTS AND DISCUSSIONS**

The forces applied are 1900, 1266.7, and 1266.7 N on SM, LB, and SA, respectively. Figure 3 shows the typical von Mises stress distribution on the steering knuckle for each type of loading. The result revealed that the critical area is the neck of SM, where stress distribution was at maximum. This observation is caused by the critical workload of SM, which supports the suspension system and weight of the car.

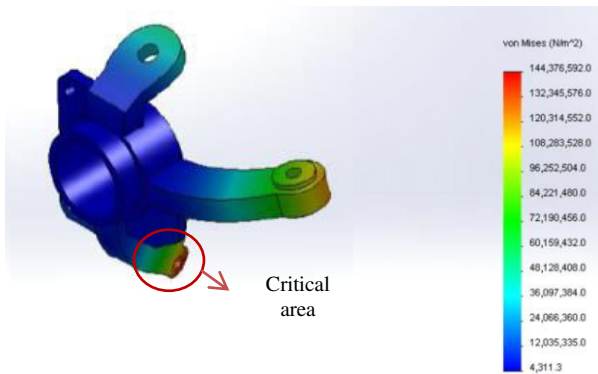

**Figure-3.** Location of critical area (maximum stress) on the steering knuckle.

The FEA results in the three points where force is applied can be analyzed in terms of maximum displacement, fatigue damage percentage, and factor of

safety (FS). Table-5 shows the results of the analysis on the critical area. The highest displacement maximum and damage percentage, that is, 0.46 mm and 8.32%, respectively, were recorded at 1900 N, the highest force applied. Moreover, the lowest value (0.90) for FS is recorded at 1900 N in SM.

The following finding highlights the effect of force with displacement on the steering knuckle. The minimum value of displacement is 0.32 mm recorded at 1500 N, whereas the maximum value is 0.46 mm at 1900 N. The increment of damage percentage is 43.75% relative to the first test result obtained at 1500 N. Figure-4 shows that increasing the force would proportionally affect the displacement. The relationship between maximum displacement and applied force can be expressed by the below equation:

$$DM = - 0.003F - 0.142 \tag{1}$$

**Table-5.** Summary of FEA results on the critical area of the steering knuckle.

No. of Test	Force applied, F (N)			Disp. Max, DM (mm)	Damage, D (%)	Factor safety, FS
	SM	LB	SA			
1	1500.0	1000.0	1000.0	1.20	0.32	2.55
2	1600.0	1066.7	1066.7	1.12	0.39	3.53
3	1700.0	1133.3	1133.3	1.06	0.41	6.03
4	1800.0	1200.0	1200.0	1.00	0.43	6.38
5	1900.0	1266.7	1266.7	0.90	0.46	8.32

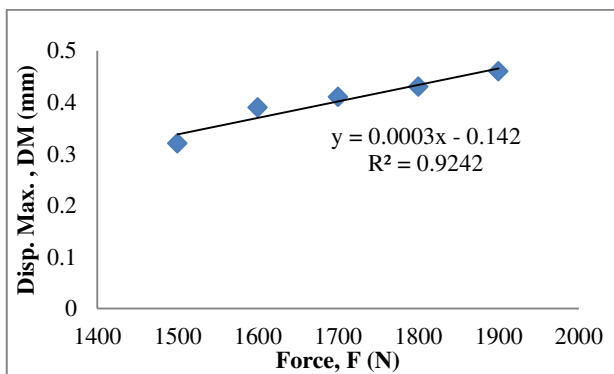

**Figure-4.** Relationship between maximum displacement and applied force.

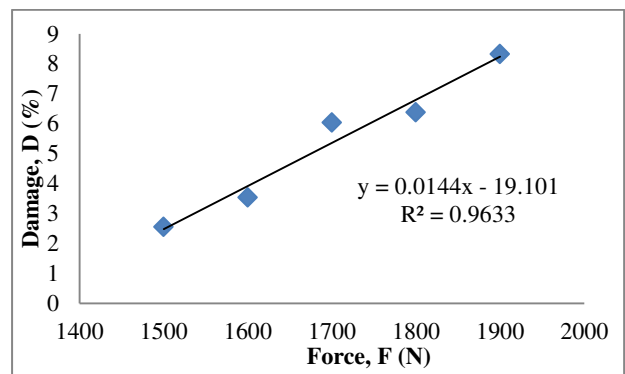

**Figure-5.** Relationship between fatigue damage and applied force.

Fatigue damage is one of the prime causes of machine defects found in industry. The detection of this type of damage is considerably difficult and hinders maintenance scheduling [10]. The results of the present study also show the relationship between fatigue damage percentage and the force applied on the steering knuckle. Figure-5 shows that the highest damage percentage is 8.32% at 1900 N, whereas the lowest damage is 2.55% at 1500 N.

The value increases up to approximately twice that of the first test result obtained at 1500 N. Thus, the higher the force exerted on the steering knuckle, the higher the damage will be. The relationship between fatigue damage of steering knuckle applied force can be represented by the below equation:

$$D = 0.0144F - 19.101 \tag{2}$$

Our finding also demonstrates the effect of increasing force on the FS of the steering knuckle. Figure-6 shows that the highest FS of 1.2 is recorded during the



first test at 1500 N, whereas the lowest FS is 0.9 at 1900 N. The percentage of decrement of FS is 25% compared with that in the first test. Hence, the higher the force subjected on steering knuckle, the lower is the FS. This finding is consistent with Equation. 3, which shows that FS is inversely proportional to design load. The equation for FS relates to applied force is shown in Equation. 4:

$$FS = \frac{\text{Material strength}}{\text{Design load}} \quad (3)$$

$$FS = -0.0007F + 2.28 \quad (4)$$

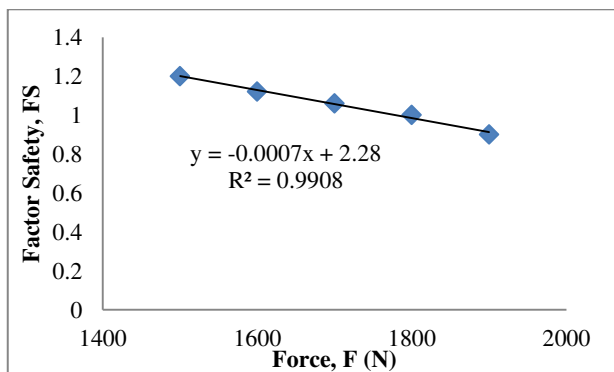

**Figure-6.** Relationship between factor safety and applied force.

## CONCLUSIONS

This paper presents the results of the analysis on the steering knuckle under stress using commercial FEA simulation. Five different sets of loading were tested and we conclude that different loadings will give different results. The results showed that as the force exerted on steering knuckle is increased, the displacement also increases. Moreover, the damage percentage incrementally increases with force. The damage percentage also affects the value of life cycle as damage percentage is inversely proportional to the number of life cycle. However, the value for FS decreases when force increases.

Overall, this study has demonstrated the effects of variable loads on the displacement, fatigue damage, and FS of the steering knuckle. Further study on fatigue damage will be conducted using the actual fatigue strain signal, which is obtained from a steering knuckle in operation. The result is soon being validated with next experiment work. A wide array of materials for steering knuckle exists, and research on the type of material to be used in producing steering knuckle is another option to further this study.

## ACKNOWLEDGEMENT

The author would like to express gratitude to Universiti Teknikal Malaysia Melaka for supporting this research activities under the grant FRGS/2/2014 TK01/FKM/03/F00234.

## REFERENCES

- [1] K. S. Bhokare, G. M. Kakandikar S. S. Kulkarni, "Predicting the Fatigue of Steering Knuckle Arm of a Sport Utility Vehicle while Deploying Analytical Techniques using CAE" International Journal of Scientific Research and Management Studies (IJRMS), Vol issue 11, pp. 372-381.
- [2] B. Babu, M. Prabhu, P. Dharmaraj, R. Sampath, "Stress Analysis on Steering" 2014 IJRET Vol 3 Issue:3, eISSN: 22319-1163.
- [3] Shazwan M. M. Z, 2009, "Analysis of Multiaxial Force Acting on Uneven Surfaces" Universiti Teknikal Malaysia Melaka: Thesis Bachelor.
- [4] K. A. Zakaria, S. Abdullah, M. J. Ghazali, "Elevated Temperature Fatigue Life Investigation of Aluminium Alloy based on the Predicted S-N Curve", Journal Teknologi (Sciences & Engineering), June 2013, pp. 75-79.
- [5] Seco Tool Ab, 2014, Proven Solutions for Steering Knuckle.
- [6] E. A. Azrulhisham, Y. M. Asri, A.W. Dzuraidah, N.M. Nik Abdullah, A. Shahrum and C. H. CheHassan, "Evaluation of Fatigue Life Reliability of Steering Knuckle Using Pearson Parametric Distribution Model" International Journal of Quality, Statistics, and Reliability Volume 2010.
- [7] P. Dumbre, Prof A. K. Mishra, V.S. Aher, S. S. Kulkarni, "Structural Analysis of steering Knuckle for Weight Reduction", International Journal of Advanced Engineering Research and Studies April-June, 2014, pp. 86-86.
- [8] L. H. Van Vlack, 1982 "Materials for Engineering: Concepts and Application", Addison-Wesley Publishing Company, Reading, MA.
- [9] M. Zoroufi, A. Fatemi, 2003, "Fatigue Life Comparisons of Competing Manufacturing Process: A Study of Steering Knuckle", SAE International.
- [10] Bounou, D., Guillet, F., Badaoui, M. E., Lyonnet, P., & Rosario, T. 2015. "Fatigue damage detection using cyclostationarity". Mechanical Systems and Signal Processing, pp. 58-59.