

Journal of Theoretical and Applied Information Technology

Open Access ⓘ

Scopus coverage years: 2005, from 2009 to 2017

Publisher: Asian Research Publishing Network (ARPN)

ISSN: 1992-8645 E-ISSN: 1817-3195

Subject area: [Computer Science: General Computer Science](#) [Mathematics: Theoretical Computer Science](#)

[Visit Scopus Journal Metrics ↗](#)

CiteScore 2016 ⓘ
0.34

SJR 2016 ⓘ
0.167

SNIP 2016 ⓘ
0.387

[View all documents >](#)

[Set document alert](#)

[Journal Homepage](#)

[CiteScore](#) [CiteScore rank & trend](#) [Scopus content coverage](#)

CiteScore **2016** ⌵ Calculated using data from **31 May, 2017**

$$= \frac{\text{Citation Count 2016}}{\text{Documents 2013 - 2015}^*} =$$

*CiteScore includes all available document types [View CiteScore methodology >](#) [CiteScore FAQ >](#)

CiteScore rank ⓘ

Category	Rank	Percentile
Computer Science		
General Computer Science	#149/191	21st
Mathematics		
Theoretical Computer Science	#107/113	5th

[View CiteScore trends >](#)
[Add CiteScore to your site ↗](#)

ⓘ Updated monthly

Metrics displaying this icon are compiled according to Snowball Metrics ↗, a collaboration between industry and academia.

About Scopus

- [What is Scopus](#)
- [Content coverage](#)
- [Scopus blog](#)
- [Scopus API](#)
- [Privacy matters](#)

Language

- [日本語に切り替える](#)
- [切换到简体中文](#)
- [切换到繁體中文](#)
- [Русский язык](#)

Customer Service

- [Help](#)
- [Contact us](#)

LINEAR AND NONLINEAR DYNAMIC MODELING OF MOTORIZED PROSTHETIC HAND SYSTEM

M.H.JALI^{1,A}, N.A.RASHID^{2,B}, M. N.KAMARUDIN^{3,C}, R.GHAZALI^{4,D}, H.I.JAAFAR^{5,E}

^{1,2,3,4,5}Faculty of Electrical Engineering, Universiti Teknikal Malaysia Melaka, Melaka, Malaysia

Email : mohd.hafiz@utem.edu.my^a, nadiaabdrashid@ymail.com^b, nizamkamarudin@utem.edu.my^c,

rozaimi.ghazali@utem.edu.my^d, hazriq@utem.edu.my

ABSTRACT

This paper described the dynamic modeling of motorized prosthetic finger system. Recently prosthetic hands become more importance because its capability to become potential substitute hand for amputee. By using various type of actuators, prosthetic hands become more practical as it could operate with neuro motors energy which initiated by the Automatic Nervous System (ANS) of the brain. However the mathematical modeling of the system needs to be appropriately determined to ensure the accuracy of the control design later on. This paper explained the linear and nonlinear dynamic modeling of the system using Lagrangian equation. The model of the system is derived by considering the energies of the finger when it is actuated by the DC motor. The linear and nonlinear model based on the Lagrangian function of the motion of the finger is evaluated based on the characteristic of the output response. The results show the significant finding of the output characteristic of the linear and nonlinear dynamic modeling of the system.

Keywords: *Prosthetic finger; Lagrangian function, Dynamic modeling, Linear & Nonlinear*

1. INTRODUCTION

Prosthesis has become one of the essential tools to replace the lost limb's physiological appearance. It could restore some of the normal functional limb that was lost due to war, congenital conditions and accidents. In addition, the interchangeable prosthesis that only been used when needed has attract a lot of researcher to explore in this field. A lot of effort to develop a prosthesis that could emulate the real human hand has been conducted in term of function, psycho-spiritual sense and cosmetic appearance. One of the most important criteria for an effective prosthetic device is the control quality. Even though numerous studies has been conducted to improve the prosthetic control, it still substantial difference in term of control quality between the prosthetic hand and real human hand. Recent survey shows that amputees need more life-like manner functional prosthetic hand and more intuitive controlled [1].

Human hand is capable to perform several gripping task such as exploration, adaptation, perception, manipulation and pretension [2]. Prosthetic hand is divided to three parts of finger considering one dimension that has similarity with the compound pendulum. Human finger movement can be model using Lagrangian motion equation similar to the compound pendulum by considering the linearity.

To imitate the functionality and motion characteristics of the real human hand, biomimetic studies of the human hand has become important [3]. In several studies, biomechanical models of the human hand fingers have been developed for determining the kinematical and dynamical behaviour of hands and fingers. As a part of the project, this paper presents a methodology for dynamic modeling and trajectory tracking of a prosthetic finger.

Mathematical modeling is treated as pre-develop phase before the control approach is applied to the real hardware device. There are several well-known approaches such as Lagranges's equation, Newton-Euler method Kane's approach and forward recursive formulation. Mathematical modeling is not simply an easy task. It composed the application of numerous mathematical rule in order to derive an appropriate equations. In order to design a good control design, the main focus of this research work is to accurately model the prosthetic hand system. The human finger has a complex structure and it is not easy task to model them. This is the motivation and challenge of this research work. Based on previous studies, motorized finger model is not yet been derived, thus the significance of this research work is to fill in the gap of the knowledge

regarding the dynamic modeling of the prosthetic system.

This paper will first explain the derivation of the dynamic model of the prosthetic finger and follow by the DC motor expression for the finger actuation. Subsequently, the simulation is perform for both linear and nonlinear model to observe the output characteristic of the open loop system. Finally the research finding is discussed for both model.

2. METHODOLOGY

2.1 Modeling of Prosthetic Finger

2.1.1 Dynamic model of finger mechanism

Based on Figure 1 the Lagrangian method is used to derive the dynamic modeling of the system. In dynamic part, the equation have been derived to find out the torque finger [4]. Table 1 shows the dynamic parameters and symbol that is used for one degree of freedom prosthetic finger.

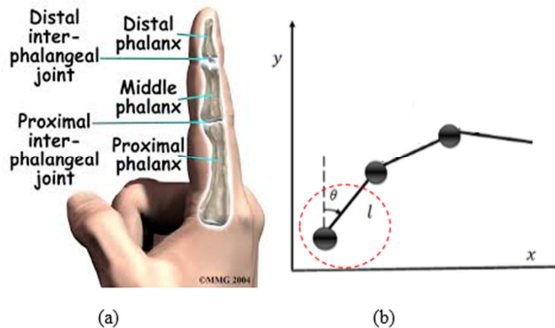

Figure 1 (A) Structure Of Human Finger. (B) Flexion Of Angles Of One Finger

Table 1 Dynamic Parameter Of 1 Degree Of Freedom

Symbol	Parameter
l	Length
m	Mass
v	Linear velocity
ω	Angular velocity
g	Gravity (9.81 ms ⁻¹)

From the previous study, it shows that Lagrange Equation is frequently used to derive the model of prosthetic hand. Therefore, Lagrange Equation is chosen for the mathematical modeling system.

$$\text{The Lagrangian, } L = T - V \quad (1)$$

T= Kinetic energy
V= Potential energy

By using the trigonometric method,

$$x = l \cos \theta \quad (2)$$

$$y = l \sin \theta \quad (3)$$

Referring equation forward kinematic above, the angular velocity is computed using Euler Lagrange formula [5].

$$\omega = \frac{d\theta}{dt}$$

$$\text{The angular velocity, } \omega = \dot{\theta} \quad (4)$$

Then, the linear velocity of mass center of the finger was found using Euler Lagrange formula [5].

$$\dot{x} = -\frac{1}{2} l \sin \dot{\theta} \quad (5)$$

$$\dot{y} = \frac{1}{2} l \cos \dot{\theta} \quad (6)$$

The equation of the velocity linear above should be square and sum of the equation to find the value.

$$\text{Velocity linear, } Vl = \dot{x}^2 + \dot{y}^2 \quad (7)$$

$$Vl = \frac{1}{4} l^2 \dot{\theta}^2 \quad (8)$$

The Kinetic energy, T

$$T = \frac{1}{2} \sum (mV + l\omega^2) \quad (9)$$

$$T = \frac{1}{2} l \dot{\theta}^2 \left(\frac{1}{4} ml + 1 \right) \quad (10)$$

The Potential energy, V

$$V = \frac{1}{2} \sum mgy \quad (11)$$

*note that gravity, g = 9.81ms⁻¹

$$V = \frac{1}{2}(mgl \sin \theta)$$

(12)

The kinetic energy, T in equation (10) and potential energy, V in equation (12) of the whole system are:

$$T = \frac{1}{2} l \dot{\theta}^2 \left(\frac{1}{4} ml + 1 \right)$$

(13)

$$V = \frac{1}{2}(mgl \sin \theta)$$

(14)

$$L = \frac{1}{2} l \dot{\theta}^2 \left(\frac{1}{4} ml + 1 \right) - \frac{1}{2}(mgl \sin \theta)$$

(15)

2.1.2 DC motor expression in the Euler Lagrange equation.

By using the Lagrange-Euler formulation, the equation of motion for 1 DOF can be written as:-

$$\frac{d}{dt} \left(\frac{\partial L}{\partial \dot{\theta}} \right) - \frac{\partial L}{\partial \theta} = F$$

(16)

$$\frac{d}{dt} \left(\frac{\partial L}{\partial \dot{\theta}} \right) = \frac{l^2 \ddot{\theta} m}{4} + l \ddot{\theta}$$

(17)

$$\frac{\partial L}{\partial \theta} = \frac{(mgl \cos \theta)}{2}$$

(18)

The following equation of motion can be obtained as:

$$\left(\frac{l^2 \ddot{\theta} m}{4} + l \ddot{\theta} \right) - \frac{(mgl \cos \theta)}{2} = F$$

(19)

To obtain a closed-form dynamic model of the prosthetic hand, the energy expression in equation (17) and (18) are used to formulate the Lagrangian $L = T - V$. To describe the equation of motion the Euler-Lagrange equation (16) is used as shown below.

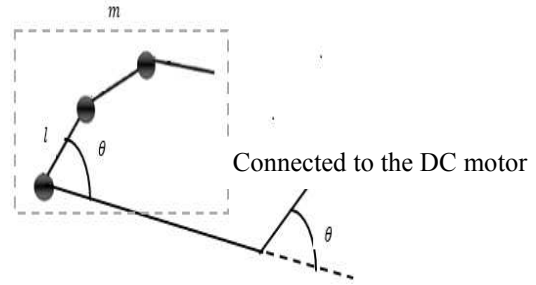

Figure 2 Prosthetic Finger's Free Body Diagram (FBD).

Figure 2 is the FBD of the prosthetic finger that will be used in this project. The finger's movement can be described with one degree of freedom model (1 DOF). From the figure, it is observed that the angle between the finger and angle that is connected to the DC motor are the same, which is rigid.

From the equation (20) and (21), F is representing to external force. The equation of force is obtain as:-

$$F = Fx - B\dot{x}$$

(20)

$$F = \frac{V kt z}{R} - \left[\frac{Ke Kt z^2}{R} \right]$$

(21)

An electrical and mechanical part of the DC motor that connected to the prosthetic finger can be expressed by,

$$\left(\frac{l^2 \ddot{\theta} m}{4} + l \ddot{\theta} \right) - \left(\frac{mgl \cos \theta}{2} \right) = F - B\dot{x}$$

(22)

$$\left(\frac{l^2 \ddot{\theta} m}{4} + l \ddot{\theta} \right) - \left(\frac{mgl \cos \theta}{2} \right) + B\dot{x} = F$$

(23)

The force in equation (16) derived from the DC motor as in Figure 3.

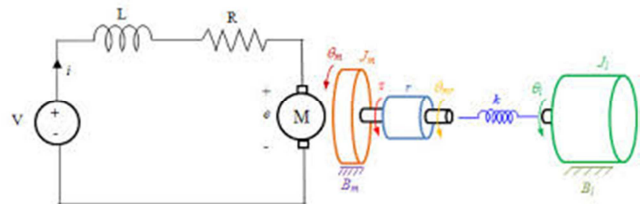

Figure 3 Field Controlled DC Motor

By using Kirchoff Current Law in Figure 2, equation (24) is derived.

$$V = Ri + L \frac{di}{dt} + Vb \tag{24}$$

Notice that inductance, L is neglected because the value is too small. Vb is back- emf voltage, due to Faraday’s Laws in equation (25).

$$V = Ri + Vb \tag{25}$$

- Where, V: Voltage
 R: Resistance
 I_a: Armature current
 L: Inductance
 T_m: Motor torque
 T_L: Load torque

A field controlled motor is shown in the Figure 3 above. For a field controlled motor, a field circuit has in input voltage, V, is applied to the DC motor. So, instead of controlling the current directly to a motor, the electric field is varied to control motor speed.

$$V = R \left(\frac{Tm}{Kt} \right) + Ke \frac{d\theta m}{dt}, \tag{26}$$

noticed that $Tm = \frac{TL}{r}$, where $TL = F$ and $\theta m = rx$

$$V = R \left(\frac{TL}{Kt} \right) + Ke \frac{d}{dt}(zx) \tag{27}$$

$$V = \frac{RF}{Ktz} + Kezx\dot{x} \tag{28}$$

$$\frac{RF}{Ktz} = V - Kezx\dot{x} \tag{29}$$

$$F = \frac{VKtz}{R} - \frac{KeKtz^2}{R} \dot{x} \tag{30}$$

Then, substitute (23) into (30) which is included the mechanical part of the prosthetic finger.

$$\left(\frac{l^2 \ddot{\theta} m}{4} + l\ddot{\theta} \right) - \left(\frac{mgl \cos \theta}{2} \right) + B\dot{x} = \frac{VKtz}{R} - \frac{KeKtz^2}{R} \dot{x}$$

$$V = \left[\frac{R}{Ktz} \right] \left(\frac{l^2 \ddot{\theta} m}{4} \right) + \left[\frac{R}{Ktz} \right] (l\ddot{\theta}) - \left[\frac{R}{Ktz} \right] \left(\frac{mgl \cos \theta}{2} \right) + \left[\frac{RB}{Ktz} + Kez \right] \dot{x} \tag{32}$$

The nonlinear equation of position/theta is computed as:

$$\ddot{\theta} = \frac{V + \frac{Rmgl \cos \theta}{2Ktz} - \frac{RB\dot{x}}{Ktz} - Kezx\dot{x}}{\frac{Rl^2 m}{4Ktz} + \frac{Rl}{Ktz}} \tag{33}$$

Thus it is easier to implement linearization to get a linear model. For that purpose, assumption considered was that deflection angle θ is very small, and also has small angular velocity $\dot{\theta}$. That means we have to satisfy the following conditions:

And the linear equation of position/angle $\ddot{\theta}$,

$$\ddot{\theta} = \frac{V - Kezx\dot{x} + \frac{Rmg}{2Ktz} - \frac{RB\dot{x}}{LKtz}}{\frac{RLm + 4R}{4Ktz}} \tag{34}$$

After obtain the transfer function, next step will be to configure this equation and simulate it using MATLAB/Simulink to analysis its step response.

2.1.3 Simulation model of linear and nonlinear prosthetic finger movement system

This part describes the result from the Euler Lagrange that need to be simulate in order to see the data response. By using Simulink in MATLAB software the equation from Euler Lagrange can be identify to be usable or not. Figure 4 shows the subsystem in block diagram of the Prosthetic Finger System.

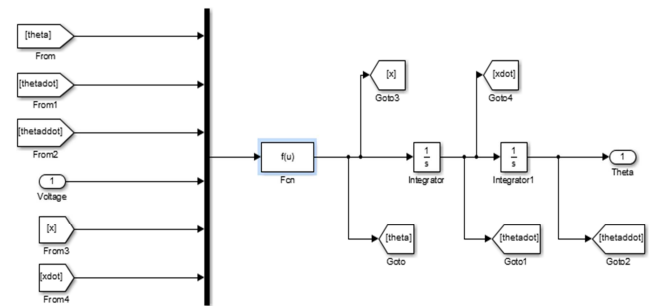

Figure 4 Subsystem In Block Diagram Of The Prosthetic Finger System

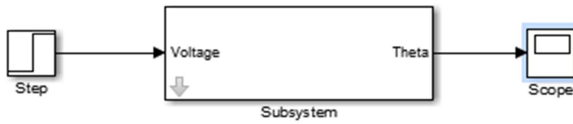

Figure 5 Block Diagram Of Prosthetic Finger System Simulated In Simulink

Figure 5 shows the Simulink of block diagram. The parameter in linear finger movement that implement in MATLAB shows in Figure 6 [6]. The control parameter of the system is a position/theta [7]. The specification of payload which is used in finger movement system are described in Table 2 and Figure 7. From the figure of subsystem, it shows that the voltage as the input and position/theta as the output. All the parameters have been set up as followed. Step input is applied as an input voltage and it has been set as 1 Volts. The step input signal is representing as the supply to operate movement of finger. Step input is the time behavior of the output of a general system when its input change from zero to one in a very short time. The characteristic of finger movement system is analyzed.

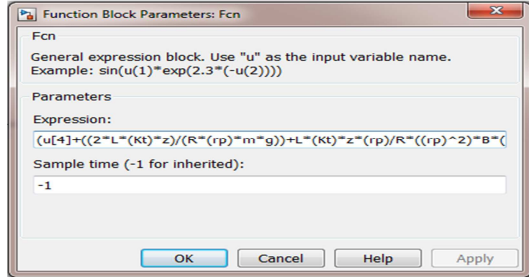
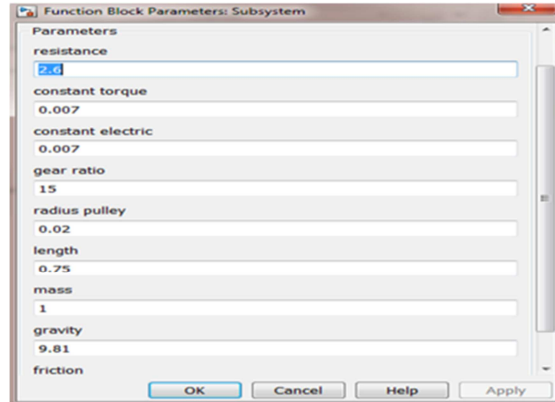

Figure 6 Expression Block In MATLAB

Table 2 List Of Parameters

Parameters	Unit	Values
Resistance	R	2.6Ω
Constant torque	Kt	0.007NmA ⁻¹
Constant electric	Ke	0.007Vsrad ⁻¹
Gear ratio	z	15
Radius pulley	rp	0.02m
Length	L	0.75
Mass	m	1
Gravity	g	9.81
Friction	B	12.32

Figure 7 Parameters That Implement In Simulink



3. RESULT AND DISCUSSION

3.1 Euler Lagrange Linear and Nonlinear Output Response

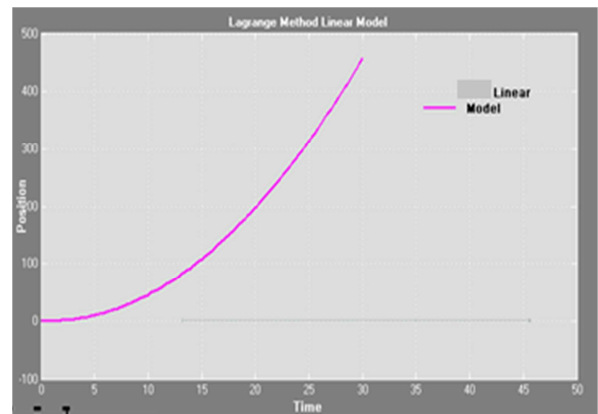

Figure 8 Euler Lagrange Linear Output Response

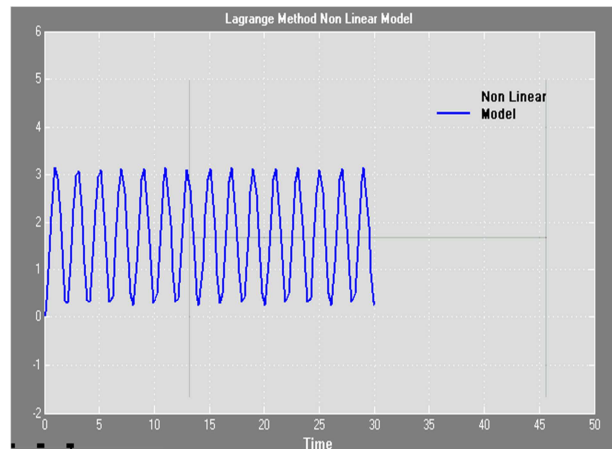

Figure 9 Euler Lagrange Nonlinear Output Response

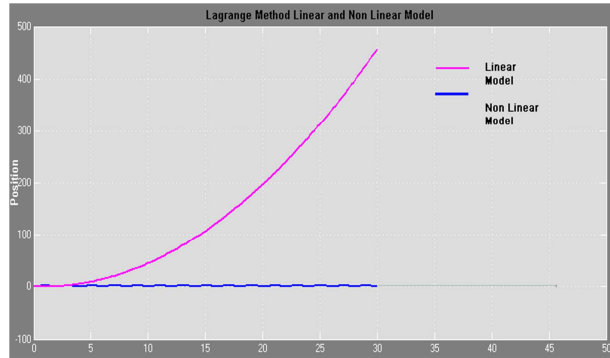

Figure 10 Linear and Nonlinear System Trajectory

Figure 8 shows the linear output response while Figure 9 shows a nonlinear output response. It shows a quite different character because in linear systems, input/ output frequency domain methods are known to be effective. However, in a non-linear system, poles, zeros, frequency domain, phase and gain margin are not defined. Thus, solving non-linear system requires advanced control technique. A Linear system can be stabilized by linear controllers such as pole placement approach, linear quadratic regulator (LQR), linear quadratic Gaussian (LQG), model reference adaptive control (MRAC), proportional-integral-derivative (PID) technique and much more [8].

In some cases, linearization of a nonlinear system is normally obtainable by using Jacobian matrix equilibrium point. Then, by using the linearized system, a simple linear controller can be applied to achieve stabilization. However, the controller will not be able to guarantee stabilization beyond the wide range of non-linear sector. The contradiction between the actual non-linear system and its linearized version would devise a cunning test to control engineers. In fact, stabilizing task becomes difficult when non-linearity is taken into consideration and linearization model of such system is omitted. The contradiction between the actual non-linear system and its linearized version in Figure 10 would devise a cunning test to control engineers.

Based on these results, there is significance finding on the output characteristics of linear and nonlinear model of the prosthetic hand system. The difference is caused by the certain parameter that has been eliminated during the linearization. This finding will help a control engineer to decide either to perform analysis in a linear model or nonlinear model. In linear systems, input/ output frequency

domain methods are known to be effective. However, in a non-linear system, poles, zeros, frequency domain, phase and gain margin are not defined. Thus, solving non-linear system is quite complicated and requires advanced control technique.

4. CONCLUSION

There are two parts in the modeling system that consists of mechanical and electrical parts. Respectively the finger and the dc motor. Both parts can be attributes together to produce new equation where the angle/ DOF of the finger controlled by input voltage. The advantages of this system is simpler and not complicated compared to other systems. By using this system, only one DOF instead of three DOF will be taken on the prosthetic finger. This mechanism will help in reduces the weight of the prosthetic finger model by not using too many DC motors that responsible to control all the movement of the finger.

Based on the findings, the Nonlinear Euler Lagrange equation is preferable to use in this plant system since this nonlinear equation is more accurate than the linear equation. It is because the linear equation will eliminate certain parameter during linearization process and linearization condition. The linearization process affected the output response of the plant system. Thus, the nonlinear equation is capable to emulate the plant more accurate that will affect the control system design later on.

ACKNOWLEDGEMENT

The authors would like to thank Universiti Teknikal Malaysia Melaka (UTeM) and Ministry of Higher Education thru research grant with code number RAGS/1/2015/TK0/FKE/03/B00097.

REFERENCES

- [1] D. G. Smith, J. W. Michael, and J. H. Bowker, Atlas of Amputation and Limb Deficiencies - Surgical, Prosthetic, and Rehabilitation Principles: American Academy of Orthopaedic Surgeons, 2004
- [2] Chao, E.Y.S., An, K., Cooney, W.P. and Linscheid, R., Biomechanics of the Hand, Teaneck, NJ. USA: World Scientific Publishing Co. Pte.Ltd., 1989, pp. 5- 75.



- [3] Venkataraman, S.T. and Iderall, T., Dexterous Robot Hands, New York, NY: Springer-Verlag New York Inc., 1990, pp. 136-149.
- [4] Ronen Ben-Horen, Morshe Shoham and Shlomo Djerassi, "Kinematic, Dynamic and construction of a Planarly Actuated Parallel Robot", Medical Robotic Laboratory, 1999
- [5] J. K. Salisbury M.T. Mason: "Robot Hands and the Mechanics of Manipulation", MIT Press, Cambridge, MA, 1985.
- [6] M.H.Jali, T.A.Izzuddin, R.Ghazali, N.E.S.Mustafa, H.I.Jaafar, H.Sarkawi, "System Identification Modeling of Arm Rehabilitation Devices", Journal of Theoretical and Applied Information Technology, vol. 81, no.3, pp 547-551, 2015.
- [7] M.H.Jali, M.K.Alias, R.Ghazali, T.A.Izzuddin, H.I.Jaafar, "Development of Prosthetic Hand Hardware and Its Control System", International Journal of Soft Computing and Engineering (IJSCE), vol. 5, no. 5, pp. 28 -31, 2015
- [8] M.H.Jali, N.E.S.Mustafa, T.A.Izzuddin, R.Ghazali, H.I.Jaafar, " ANFIS-PID Controller for Arm Rehabilitation Device", International Journal of Engineering and Technology (IJET), vol 7, no 5, pp 1589-1597, 2015