



## DEVELOPMENT OF PORTABLE MAGNETIC CLAMPING FOR LATHE MACHINE

N. Ab Wahab, Afferry Bin Mohd Saleh, Abd Khahar Bin Nordin, Nor Fauzi Bin Tamin,  
 Mohd Azimin Bin Ibrahim, Suziana Ahmad and Dayanasari Binti Abdul Hadi  
 Faculty of Engineering Technology, Universiti Teknikal Malaysia, Melaka, Malaysia  
 E-Mail: [norfariza@utem.edu.my](mailto:norfariza@utem.edu.my)

### ABSTRACT

Chuck is a device used to clamp any material that operates with the turning of the machine and it is connected to the headstock spindle of the lathe. However, the limitation is that the thickness of the workpiece must not be less than the area of clamping on the chuck. In this a new magnetic clamping for attaching and detaching the workpiece on the chuck and is able to clamp small and thin workpieces is developed. The chuck is made by using mild steel and has a few intercepts with brass. Magnetic mechanism is placed in the chuck. Several cutting processes were done with the convectional chuck and the magnetic clamping on a different thickness of workpiece. Next, all the workpieces were tested with several parameters on specimen and perform surface roughness testing to compare and finalize the effectiveness of the magnetic clamping. From the obtained result, the use of the magnetic clamping produces much better result of surface roughness on thin workpiece. Thus, using magnetic clamping as the clamping method for thin workpiece is much effective in turning machine.

**Keywords:** lathe, magnetic clamping, chuck.

### INTRODUCTION

Chuck is a model of clamping device that is used to support an item, usually with radial balance, especially the round part. It is usually used to support a spinning device or spinning workpiece. Some chucks can also keep irregularly form things. Magnetic clampings are usually used for the fixturing of ferromagnetic material in perfection of switching functions. This magnetic clamping typically uses an electromagnet or permanent magnet to hold the material or workpiece during machining. (Felix and Melkote, 1999).

The main advantage for this magnetic clamping is to make it easy to attach and detach the workpiece, and it able to clamp small and thin workpiece. Magnetic clamping also offer several advantages over conventional clamping methods such as three-jaw chucks. Compared with the three-jaw place, magnetic clamping produces very little flexible deformation of the workpiece and thus, it enables limited perspective and form specifications to take place. This magnetic clamping is round with the flat working area on the top and an on/off change or key place on the side. Inside the chuck is a sequence of places that are organized to increase the flux along the outer lining area of the system. Flux is optimized and makes it possible to secure any ferrous materials placed on top of the system by organizing the place in a similar design.

In modern work, whereby parts get thinner and smaller, the convectional chuck is no more relevant to be used in any process of lathe. Furthermore, certain parts or workpieces have a small thickness that cannot be clamped with normal clamping and requires flat clamping to clamp flat surfaces. The objective of this project is to design, choose material and develop a magnetic clamping for the lathe machine.



**Figure-1.** Convectional 4-jaw chuck.

### RESEARCH METHODOLOGY

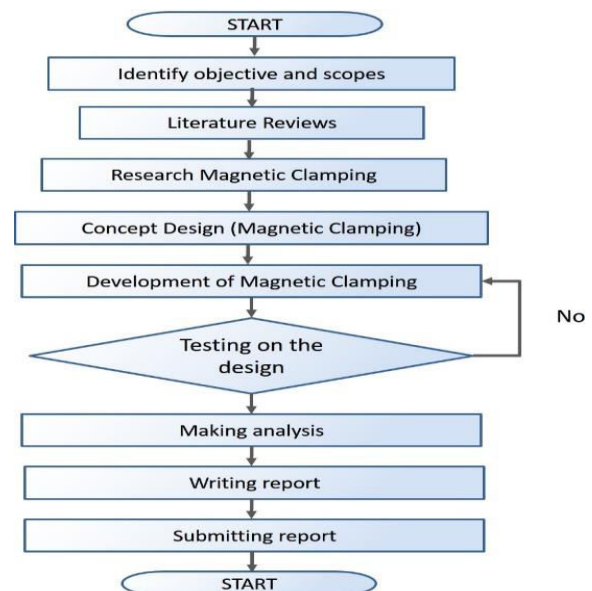

**Figure-2.** Flow chart of this study.



### A. Magnetic clamping

- In this stage, the magnetic clamping is designed based on the chuck that is available in the laboratory and few other designs in the industry market.
- By using CATIA V5 R20, the modal of magnetic clamping is drawn as Figure-3.

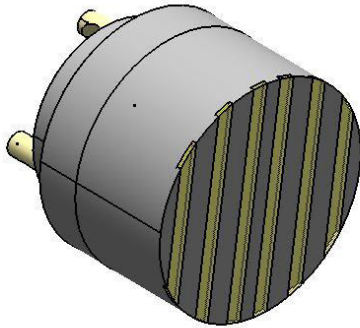

Figure-3. Magnetic clamping in 3D model.

### B. Material

- Quotation for the magnetic clamping was made to identify the material cost required to develop the magnetic clamping.
- Material that is suitable to be used and developed is the mild steel due to its magnetic conductivity properties.

No.	Parts name	Expectation size (mm)	Types of material
1	Front Base Plate (front)	154 x 5	Mild Steel
3	Plate	300 x 200 x 3	Brass
4	Screw	M6x30 (x4)	Steel
5	Magnet	10 x 16 10 x 14 10 x 8 10 x 6	Rectangle NdFeb Magnet (neodymium)
6	Spacer	155 x 2	Aluminium
7	Rear Base	155mm x 30mm	Steel

Figure-4. Quotation of the magnetic clamping.

### C. Process

- Only conventional machine will be used in the process to develop this magnetic chuck.
- Lathe machine, drilling machine, milling machine and surface grinding are used.

### D. Changes in design

- There are few changes to the earlier design due to the mechanism and type of magnet used.
- Figure-5 shows the new design in 3D model.

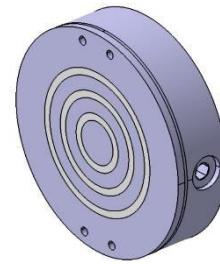

Figure-5. New design in 3D model.

### E. Fabrication

- Front base plate
  - Raw material is cut into thickness around 2mm - 25mm using the band saw.



Figure-6. Cutting process on the raw material.

- The raw material proceeds with facing process on the lathe machine using the 4-jaw chuck due to its large diameter.



Figure-7. Facing process on the raw material.

- Proceed to the milling machine process to create slots for the brass to be fitted in.

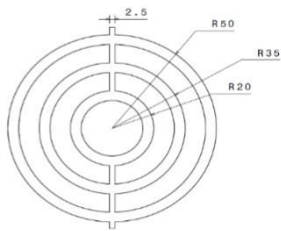

Figure-8. Slots in progress using the milling machine.



**Figure-9.** Final product of the front base plate.

- Brass
- a) Brass is fabricated by cut from a plate into the dimension based from the slot of front base plate



**Figure-10.** Dimension of the brass.

- b) This cutting process is using the water jet machine.

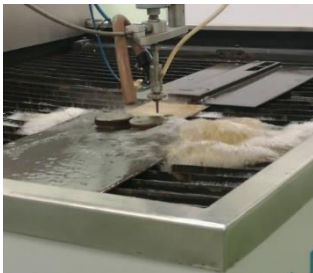

**Figure-11.** Waterjet machine cut the brass.

- c) After the brass been cut it is fitted into the slot front base plate and pressed using vise clamp on the milling machine.



**Figure-12.** Brass is fitted into the slot.

- d) Next, to get a flat surface, the front base plate is proceed with the surface grinding.



**Figure-13.** Surface grinding process.

#### F. Assembly

- a) Due to few factors, only the front base plate are produced so far.
- b) The rear base is using the reused magnetic clamping available in the market.

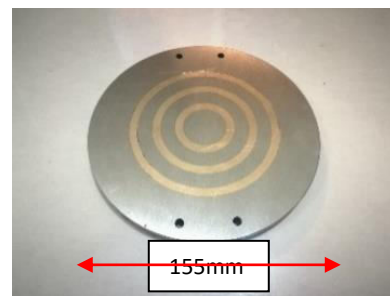

**Figure-14.** Complete front base plate.



**Figure-15.** Arrangement of the magnet.



**Figure-16.** Rea base plate.



Figure-17. Steel block.



Figure-18. Allen key screw (M6 x 40).

- First, locate the aluminium spacer and the movable magnet slot on the front base plate.
- Magnet needs to fitted into all the slots.
- Make sure the spacer is aligned with the hole of the screw between the spacer and front base plate.
- Locate the steel block into the rear base plate slot.
- Finally assemble the front base plate and rear base plate.
- Make sure the steel block is fitted and aligned with the movable magnet slot.

## RESULT AND DISCUSSIONS



Figure-19. Final product of the magnetic clamping.

### a) Mechanism of the magnetic clamping

Magnetic clamping is controlled mechanically by turning the lever off. The magnet placed inside the magnetic clamping is always in demagnetized position "off". When the lever is turned, the magnet is magnetized and it is in "on" position. This mechanism will help the magnet to create the magnetic flux in the magnetic chuck

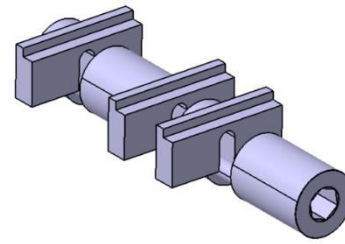

Figure-20. Mechanism used in magnetic chuck.

### b) Operation

By switching on and off the magnetic clamping, it will rearrange the position of the north and south of the magnet. These rearrangement will create magnetic field that extends to outside the devices and create holding force.

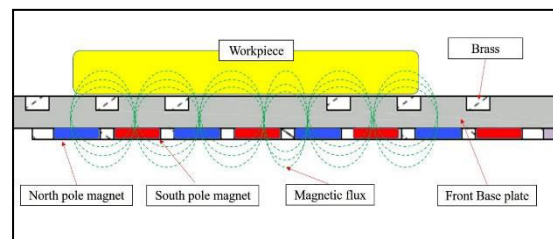

Figure-21. Magnet flux flow in the magnetic clamping.

### c) Arrangement of the magnet

The arrangement needs to be in correct sequence. The pole of every magnet needs to be clarified before located into the magnetic clamping. These poles can be identified by using a compass. Magnet is arranged in the slot with alternate position.

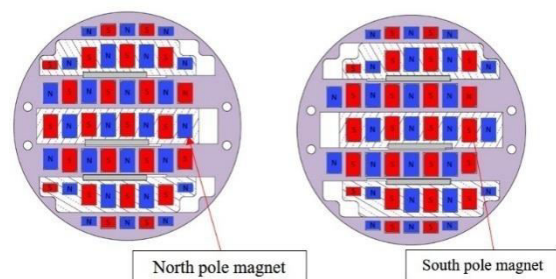

Figure-22. Arrangement of the magnet.

### d) Result

As for result, the magnetic is unable to develop completely. There are few difficulties during the development that are solved. In terms of functionality, the magnetic clamping is unable to clamp during the course of testing. This can be proven when the magnetic clamping is "on" but it does not attract any ferrous metal workpiece. Few factors influence this failure such the thickness between the brass and bottom front base plate and separator.



## A. Possibility of the failure

### a) Thickness

This thickness can be seen by the distance between the placed bottom and front base and the brass which is 3mm, while the distance between the plate surfaces is 5.5mm. This thickness prevents the magnet to create magnetic flux around the brass and create the holding force. Magnet characteristic is to find the shortest route between the north and south poles.

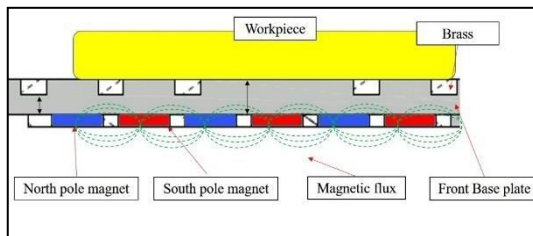

**Figure-23.** The thickness the magnetic clamping.

### b) Separator

The magnetic clamping is unable to function properly due to the separator. The brass act as the separator between the north and south pole of the magnet. The distance between the magnet and the brass is too wide. This will cause the magnet field to extend its flux outside the magnetic clamping.

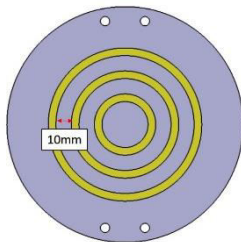

**Figure-24.** Distance between each brass.

## CONCLUSIONS

In conclusion, this work demonstrates the design and the development stage of a magnetic clamping for the lathe machine. This work shows the fabrication of a magnetic clamping and determines the functional of the magnetic clamping. There are a few factors that influence the magnetic clamping to not function properly such as the thickness of the brass, number of brass used, etc. The main goal of this study is to produce a new magnetic clamping for the student's exposure on magnetic clamping and understand the mechanism applied on the magnetic clamping that make it work.

## ACKNOWLEDGEMENT

This work was supported by the Faculty of Engineering Technology, Universiti Teknikal Malaysia Melaka.

## REFERENCES

- [1] Beddoes J. and Bibby M.J. 1999. Principles of Metal Manufacturing Processes. Principles of Metal Manufacturing Processes. pp. 232-269.
- [2] Singh R. 2006. Introduction to Basic Manufacturing Process and Workshop Technology. Zhurnal Eksperimental'noi i Teoreticheskoi Fiziki.
- [3] J Felix A. and Melkote S.N. 1999. Effect of Workpiece Flatness and Surface Finish on the Holding Force of a Magnetic clamping. Journal of Manufacturing Science and Engineering, Transactions of the ASME. 121(4): 811-814.