

# Piezoelectric Energy Harvesting System Via Impact and Vibration – A Review

N. X. Yan, A. A. Basari, K. S. Leong and N. A. A. Nawir

*Centre for Telecommunication Research & Innovation (CeTRI), Fakulti Kejuruteraan Elektronik dan Kejuruteraan Komputer (FKEKK),  
Universiti Teknikal Malaysia Melaka (UTeM), Durian Tunggal, 76100 Melaka, Malaysia.  
amat@utem.edu.my*

**Abstract**—Recently, the vibrational energy harvesting devices have been studied and developed significantly. Although battery is the main power source for electronic devices, it still has some limitations, particularly its life time. Piezoelectric transducer is one of the devices that can be used for the vibration energy harvesting system. It has higher power density compared to the others. A comprehensive review on piezoelectric energy harvesting system is discussed and presented in this paper. The techniques of the piezoelectric energy harvester such as impact and vibration modes are reviewed. The power generator developed for the impact-based piezoelectric energy harvester is addressed in this paper. It can be concluded that the piezoelectric energy harvesting system can generate output power in the range of 34.6nW to 1.34W.

**Index Terms**—Energy Harvesting; Piezoelectric Transducer; Vibration; Impact-Based.

## I. INTRODUCTION

Over the past decade, there have been extensive researches on the vibrational energy harvesting devices leading to important developments in design, efficiency, and material development. The objective of this research activity is to overcome the problem with the limitation in the lifespan of battery and the inefficiency in replacing battery of the low power consumption electronics and wireless sensor devices [1][2][3]. Vibration energy harvester is a recovery device that receives kinetic energy from vibrations or pressure. The energy harvesting refers to the collection of ambient waste energy for the purpose of generating energy for low powered electronics, which acts as an enabling technology for wireless applications.

There are three types of the vibrational energy harvesting techniques: electrostatic generator, electromagnetic induction and piezoelectricity [1][4][5]. Among the three types of energy harvesting techniques, this paper focuses on the review of the piezoelectric materials. The piezoelectric cantilever used for vibrational energy harvesting should match the resonant frequency with the available frequency in the environment for the purpose of producing maximum deformation of the piezoelectric materials and prompting a maximum electric energy.

Various techniques of energy harvesting using piezoelectric materials were reviewed in this paper. The scope consists of an investigation of the technique of the piezoelectric energy harvester in impact-based, bending and vibrational mode. This paper has three sections, which are organized as follows. Section I is the introduction. Section II of this paper will illustrate the literature review about the techniques of the piezoelectric energy harvester. And lastly, section III will summarize the content of this paper.

## II. LITERATURE REVIEW OF PIEZOELECTRIC ENERGY HARVESTER (PEH)

Piezoelectric generator on a bimorph cantilever beam has been developed in [6]. The end of the cantilever beam was attached with a proof mass in order to increase the bending motion of the cantilever beam. The paper concluded that the scavenger operating frequency bandwidth can be increased from 6Hz to 24Hz with a multiple proof masses. [7] demonstrated a piezoelectric cantilever array with magnetic tips to tune the resonant frequency related to the original resonant frequency of the beams. They found that the proposed design was able to increase the power density as long as the beams were adjusted by using a single efficient actuator. One of the benefits of this proposed design was that it has widened the range of the frequency compared to the other, yet it generated a lower power density as the power was released to a broader bandwidth of the frequency.

[8] developed a piezoelectric energy harvester, in which an impact force was applied on the piezoelectric bimorph cantilever beams. The IPEH can harvest 600 $\mu$ W of output power at 10Hz of frequency with 10cm of linear motion's amplitude, and produced 120 $\mu$ W/cm<sup>3</sup> of output power density. However, there was a limitation for the proposed IPEH, which is only one dimensional of collision was being analyzed on a flexible beam. The velocities of the objects velocities and the efforts of the direction of the collision were assumed that they are perpendicular to the surface of beam. [9] implemented a piezoelectric generator, which employed the change of the cantilever beam strain together with the weight of the tip mass of the cantilever beam. The designed was to ensure that it can have contact with the piezoelectric devices, which are positioned on both sides of the cantilever beam. The structure is shown in Figure 1. The result shows that when the initial vibration amplitude was 18mm at 18.5Hz and the DC voltages from each group was applied to different capacitors, the total output electric energy for the piezoelectric generator can provide 43nJ for one vibration. Nevertheless, in the charging loop, there was many energy losses.

[10] demonstrated a piezoelectric energy harvester that has a mechanical end stop at one side that can broaden the bandwidth of the sweep up frequency. A metal plate enclosed to the piezoelectric operated at the resonant frequency of 120Hz and optimum load resistance of 209.6k $\Omega$ . The results showed that high acceleration level after the impacts occurred result in higher output power. [11] designed a MEMS piezoelectric energy harvester that consists of a cantilever and silicon beam with ten parallel-

arrayed of PZT energy harvesting element. The structure is shown in Figure 2. They proved that the PZT element in parallel connection can generate higher output power compared with the series connection with a low load resistance. The energy harvester can generate the power from 19.4nW to 51.3nW at the operating frequency range of 30Hz to 47Hz at acceleration of 1g condition.

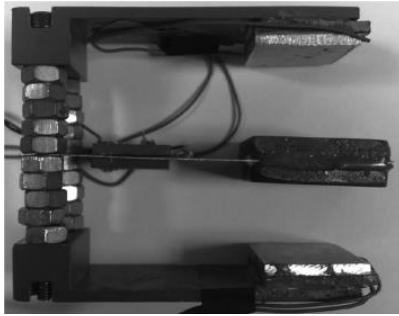

Figure 1: Photograph of the piezoelectric generator taken from the side [9].

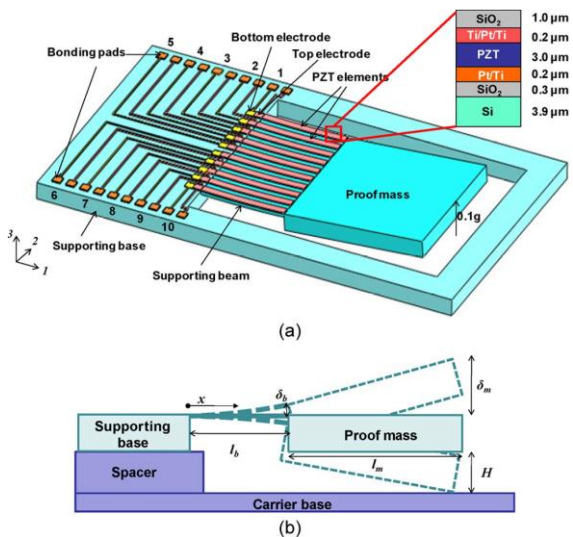

Figure 2: (a) Schematic diagram of the piezoelectric cantilever attached with a proof mass. (b) Cross-section diagram of the piezoelectric cantilever generator with a spacer [11].

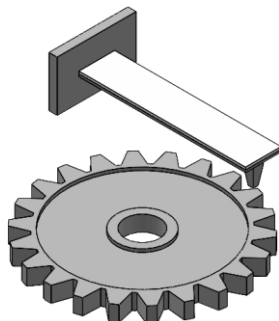

Figure 3: Schematic drawing of the piezoelectric energy harvester from a rotating object [12].

A design of an impact type of piezoelectric energy harvester in cantilever beam structure is shown in Figure 3 [12]. It has a 135μm thickness of PZT sheet attached on a silicon AFM. The energy harvester has a gear driven by an inertial mass system. The deeper the depth of the tip and the longer the displacement of the harvesting device, the larger the output power of the energy harvester. When the depth of the tip was 100μm and 2.7kΩ of a resistive load and it was connected at the output with a rotating speed of 25rpm, the energy harvester can yield an average output power of

1.26μW. [13] introduced a piezoelectric energy harvester mechanism which consists of three types of modules. The prototype of the generator is shown in Figure 4. The first module is an electromagnetic induction module, the second module is an impact mode piezoelectric energy harvesting module, while the third module is impact-induced vibration piezoelectric energy harvesting module. The third module, which is impact-induced vibration mode can harvest more electric output energy compared to the other modules. The third module produced 654.2μJ, while the first and second module produced 57.2μJ and 429.3μJ of energy respectively, at the amplitude of the base vibration of 4.5mm and frequency of 13Hz.

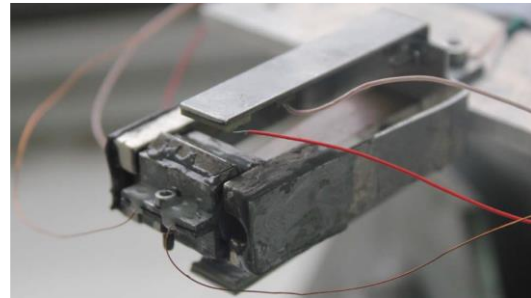

Figure 4: The hybrid generator prototype [13].

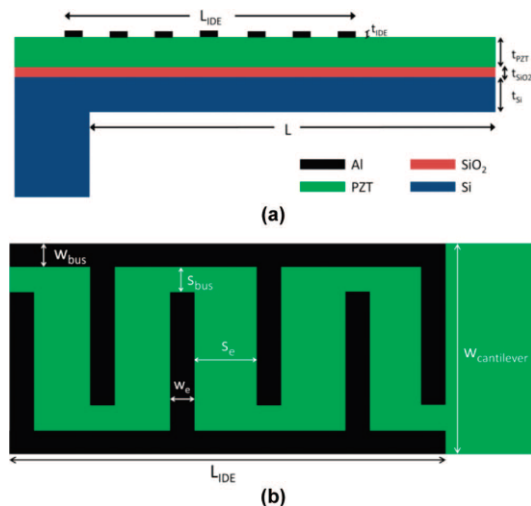

Figure 5: Schematic drawing from (a) Side view and (b) top view of a multi-layer, cantilever piezoelectric energy harvester [14].

[15] analyzed the effect of the impaction on the piezoelectric energy harvester, in which a driving beam was allocated between two piezoelectric parallel bimorph beams. The non-interacting condition and the interacting condition experiment were conducted in this research and showed that the generated output voltage and the bandwidth of the resonant frequency in the interacting condition was larger and wider when compared to the non-interacting condition. [14] demonstrated a new two-stage method based on the finite element method which is used to find the optimum thickness of piezoelectric material. The Interdigitated-Electrode (IDE) geometry for a cantilever beam, which is shown in Figure 5 is fabricated on top of a Si structural layer and a SiO<sub>2</sub> isolation layer. By bending the cantilever beam, the device converted the mechanical stress to electric field. With a 15μN force applied on the 0.6μm PZT thickness and 12 finger pairs IDE, a maximum output energy of 0.37pJ was generated.

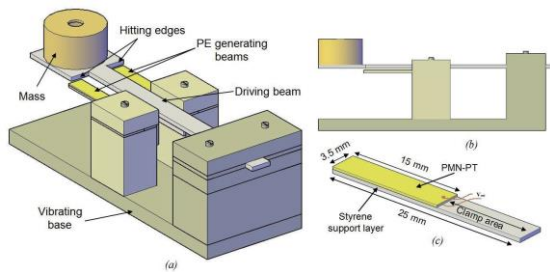

Figure 6: Schematic diagram of (a) side view (b) piezoelectric generating beam with plastic support layer (c) support layer for piezoelectric vibration energy harvester [17].

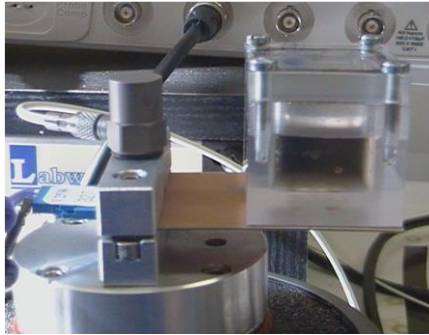

Figure 7: The piezoelectric cantilever with Perspex filled liquid mass [18].

A Double Piezo – Snap Through Buckling (DP-STB) energy harvester was designed in [16]. The energy harvester consists of a bistable clamped Poly Ethylene Terephthalate (PET) beam and two piezoelectric transducers. The type of the transducer is 7BB-35-3L0, manufactured by Murata. The piezoelectric transducers were connected in parallel configuration and an inertial mass is located in the middle of the beam. They showed that when decreasing the proof mass, the acceleration can affect the beam buckling with the distance between the stable states. Furthermore, as the frequency increased, the output power in  $\mu\text{W}$  increases as well. [19] investigated and experimentally verified a model of bimorph piezoelectric beam. The dimension of the beam is  $60 \times 5 \times 0.5\text{mm}$ . The output terminal was connected with a resistance load of  $120\text{k}\Omega$  and a capacitor with the value of  $24.6\text{nF}$ . In order to extract a beam without any physical impact, the magnetic coupling was introduced. It showed that the voltage of the repulsive magnet arrangement is greater and offer a clean declining oscillation compared to the attractive arrangement. The output voltage for the  $4\text{mm}$  initial gap of magnet arrangement is smaller than the  $2\text{mm}$  gap.

A driving beam impact with horizontally extended rectangular tip working at a low frequency range was designed in [17]. This structure makes two piezoelectric generating beams oscillated at the same time and yields an output power. The structure is shown in Figure 6. The higher the resistance load value, the higher the output voltage produced. By using a  $200\text{k}\Omega$  of load resistance, the maximum power of  $129.15\mu\text{W}$  was generated at acceleration of  $6\text{ms}^{-2}$  compared to  $46.51\mu\text{W}$  that was generated at acceleration of  $4\text{ms}^{-2}$ . Therefore, the faster the acceleration of the vibration, the higher the output load voltage as well as the output power. [20] demonstrated a structure of a piezoelectric energy harvester that consists of a magnetic stopper on one side of the main beam. Three beams were used in the piezoelectric energy harvester with non-contact connection due to the magnetic force or repelling force. The output power of the stopper beam and the single beam were

$0.1\mu\text{W}$  and  $0.098\mu\text{W}$ , respectively within the periods of  $38.8\text{s}$ .

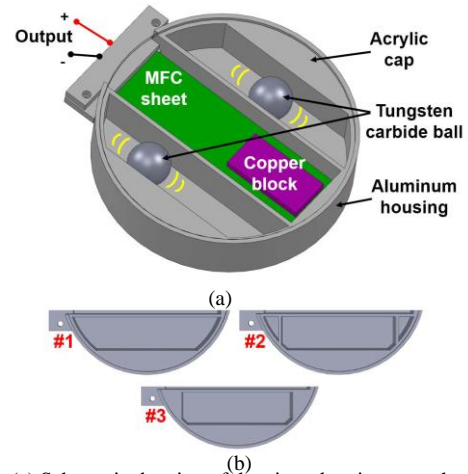

Figure 8: (a) Schematic drawing of the piezoelectric energy harvester by using tungsten carbide balls and an MFC cantilever (b) Different types of Housing for the piezoelectric energy harvester [21].

A piezoelectric energy harvester by using liquid filled mass structure is shown in Figure 7 [18]. It was used to widen the bandwidth of the operation frequency without decrease the peak output voltage. They found that the 50% of the water filled mass with  $4\text{g}$  acceleration was the best input variables. The bandwidth of the operation frequency bandwidth was increased from  $1.6\text{Hz}$  to  $4.45\text{Hz}$  without reducing the peak-to-peak voltage. A piezoelectric vibrational energy harvester which consists of a micro-machined thick silicon proof mass mounted with quad-beams engraved out of monolithic single crystal silicon was developed in [22]. The thickness of the quad Si beams was fixed, while the sizes of the structure were fixed to  $5000$ ,  $7000$  and  $10,000\mu\text{m}$  and the optimum ratio for the length of the beams ( $L_c$ ) to the edge length ( $L_p$ ) of the proof mass was identified. It showed that nine devices in array were employed to widen the bandwidth of the PVEH. Each device can widen  $50\text{Hz}$  bandwidth of frequency to obtain the range of  $100\text{Hz}$  to  $500\text{Hz}$  bandwidth of frequency. With an acceleration of  $1\text{g}$ , the generated output voltage was  $0.4\text{V}$ .

A microenergy harvesters through an impact-induced oscillation was investigated in [23]. A cylindrical cavity was used to lead a metal ball to vertically hit on the cantilever beam. The bandwidth of the frequency response was from  $20\text{Hz}$  to  $150\text{Hz}$ . When the metal ball hit on the cantilever beam at  $150\text{Hz}$  frequency with acceleration of  $39\text{m/s}^2$  and a load resistance value of  $10\text{k}\Omega$  was connected at the output,  $34.6\text{nW}$  of maximum output power was generated. An indirect impact based piezoelectric energy harvester which consists of a proof mass and a piezoelectric cantilever of MFC (Macro Fiber Composite) beam was developed in [21]. The structure is shown in Figure 8(a). The Housing 2 which has a perpendicular cavity end with the wall's thickness of  $0.5\text{mm}$ , as shown in Figure 8(b) produces the largest peak-to-peak open circuit voltage of  $23.8\text{V}$  compared to the Housing 1 and Housing 3 at the frequency of  $20\text{Hz}$  and  $3\text{g}$  acceleration. The manual vibration test was better than the vibration exciter test (the device is shaken with the vibration exciter with an acceleration of  $3\text{g}$  and frequency range from  $10$  to  $20\text{Hz}$ ) and pendulum test. The manual vibration test can produce a maximum output voltage of  $54\text{V}_{\text{max}}$ , average

output power of  $621\mu\text{W}$  and average output power density of  $135.3\mu\text{W}/\text{cm}^3$ .

[24] designed an energy harvester of a triaxial ball-impact piezoelectric converter for human motion. The  $90\text{cm}^3$  of cube

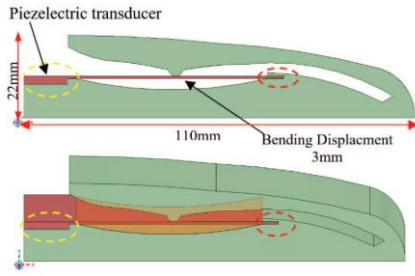

Figure 9: The proposed piezoelectric bending mechanism [25].

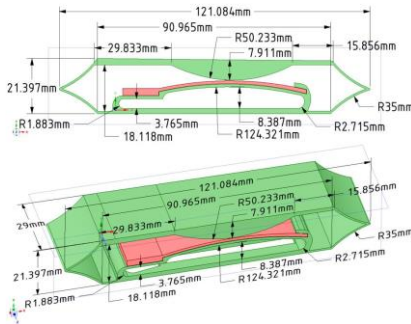

Figure 10: The proposed piezoelectric pre-stressed bending mechanism [26].

energy harvester composed of an AISI 316 stainless steel ball with diameter of 30mm. It was enclosed by three pairs of piezoelectric diaphragms. The type of the transducer is 7BB-27-4A0, manufactured by Murata. A peak instantaneous power of  $16\text{mW}$  was generated when a person was running at  $7\text{km}/\text{h}$ . The energy harvester was estimated to yield an energy of  $1.4\text{mJ}$  within 260s when walking at  $2\text{km}/\text{h}$ . A micro power piezoelectric generator was analyzed by using bending, vibration and impact methods in [27]. The results showed that the values of the generated voltage by using impact, bending and vibration methods were 4V, 0.2V and 0.2V respectively. For the impact mode, a single piezoelectric with 200 strokes/s can produce 4V of output power with 4mA of output current. Thus, the generated output power of the impact mode is equal to  $16\text{mW}$ . In order to produce output power of  $0.4\text{W}$  (20V, 20mA), 25 elements were needed to be used for the energy harvester.

[28] designed a low frequency piezoelectric-electromagnetic-triboelectric hybrid broadband vibrational energy harvester (LB-HVEH). There are three main parts: piezoelectric energy harvester (PEH), electromagnetic energy harvester (EMEH) and triboelectric energy harvester (TEH). As a result, with  $0.5\text{g}$  acceleration at frequency of  $20\text{Hz}$  and a load resistance value of  $800.1\text{k}\Omega$ , the PEH generates a maximum output power of  $41.0\mu\text{W}$ . The operating frequency bandwidth of  $3.5\text{Hz}$ . The EMEH produces a maximum output power of  $66.5\mu\text{W}$  with  $10\text{Hz}$  of operating frequency bandwidth when  $343.1\Omega$  of load resistor was used. While for the TEH, it generates a  $4.6\mu\text{W}$  of maximum output power with  $18.1\text{Hz}$  operating frequency bandwidth and load resistance value of  $1.4\text{M}\Omega$ . The PEH and TEH have high internal impedance while the EMEH has the low internal impedance. Meanwhile, the PEH and TEH can produce higher voltage compared to the EMEH. [29]

implemented a cymbal bridge transducer which composed of a square soft PZT ceramic and hardened steel end caps on the energy harvester from the impact load. The larger the resistive load, the larger the impedance of the transducer, the larger the output power of the energy harvester. For a 600lb load, each

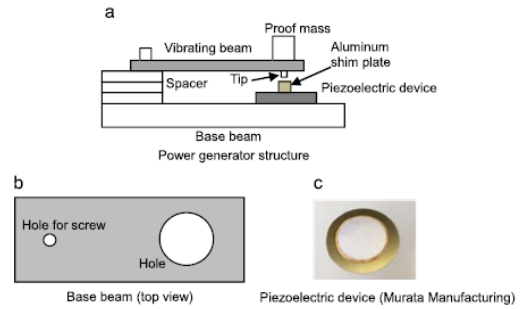

Figure 11: The power generator, base beam and piezoelectric device [30].

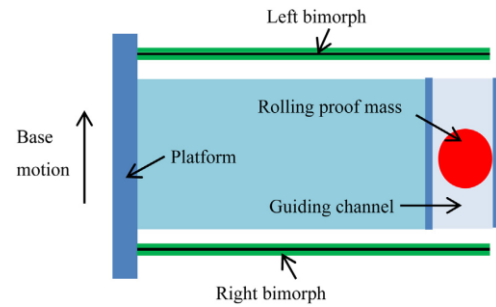

Figure 12: Schematic drawing of energy harvester with a rolling proof mass [31].

loading and unloading cycle can produce  $0.83\text{mJ}$  of output energy. A  $2.1\text{mW}$  maximum output power was harvested at frequency of  $5\text{Hz}$  and 500lb load connected with a resistive load value of  $400\text{k}\Omega$ .

A piezoelectric transducer bending mechanism with a rectangular shape of cantilever beam structure is shown in Figure 9 [25]. An impact force was suggested to be applied onto the bending beam. When  $80\text{N}$  force was employed on the piezoelectric transducer, a maximum instantaneous output voltage of  $50\text{V}$  was produced. While a  $50\text{N}$  of impact force was applied and the transducer was connected with a resistive load value of  $0.175\text{k}\Omega$ , a maximum DC output power of  $8.8\text{mW}$  was generated. After that, [26] enhanced the performance of the power generator by proposing a piezoelectric prestressed bending mechanism. The structure is shown in Figure 10. The output voltage was amplified to  $70\text{V}$  when  $80\text{N}$  force was applied.  $53\text{mW}$  of output power was amplified when a force of  $50\text{N}$  was applied. [26] can harvest larger output power than [25] by using the pre-stressed concept on the mechanism housing.

[30] demonstrated an impact mode of piezoelectric power generator by attaching a shim plate between a round piezoelectric ceramic and the hitting structure. The structure is shown in Figure 11. There are two configurations of impact mode piezoelectric power generator were evaluated in this paper: pre-load configuration and non-touching configuration. The operating frequency bandwidth of the pre-load configuration is wider when compared to the non-touching configuration. Power generator with shim plate configuration, has increased the output efficiency by 4.3 when compared to the direct impact structure.

Table 1  
Summary of literature review of piezoelectric energy harvesting.

Reference, year	Excitation	Resonant frequency (Hz)	Acceleration ( $g=9.81m \cdot s^{-2}$ )	Load resistance ( $\Omega$ )	Max output Power (W)	Outcomes
Nathan Jackson et al. [18], 2015	Vibration	Around 28 to 32	1g, 4g and 6g			50% of deionized water filled mass with 4g acceleration can broaden the widest bandwidth compared to the other parameters.
Y.S. Shih et al. [20], 2015	Vibration	26.8			0.1 $\mu$ and 0.098 $\mu$	The PEH which has the stopper beam can produced higher amplitude and higher ringing signal compared to PEH that without stopper.
S. Ju et al. [21], 2015	Impact-Based	20	3g	1k	621 $\mu$	<ul style="list-style-type: none"> <li>Housing 2 was the best among the three designed housings.</li> <li>The manual vibration test was obtained better output.</li> </ul>
Le Van Minh et al. [23], 2015	Impact-based	150	39m/s <sup>2</sup>	10k	34.6n	The main parameter: The contact time of the metal ball on the cantilever
D. Alghisi et al. [24], 2015	Impact-based	47 to 63	0.9 to 1.6 g <sub>RMS</sub>	1k	16m	1.4mJ of energy was produced when walking at velocity of 2km/h within 260s.
Kyoo Nam Choi et al. [27], 2015	Impact-based			1k	16m	The impact mode can produce output voltage that is 20 times higher than vibration and bending mode.
Xianming He et al. [28], 2015	Vibration	20	0.5g	800.1k	41.0 $\mu$	<ul style="list-style-type: none"> <li>PEH and TEH have large internal impedance compared to the EMEH.</li> <li>PEH and TEH can yield larger voltage than EMEH.</li> </ul>
Ali Mohammed abdal-Kadhim et al. [25], 2016	Impact-based			0.175k	8.8m	<ul style="list-style-type: none"> <li>The masses and height of fall free will affect the value of forces.</li> <li>The output voltage and power will be increased as the forces value increased.</li> </ul>
A.A. Basari, et al. [30], 2016	Impact-based	48	Less than 1g	10k		<ul style="list-style-type: none"> <li>The performance of the pre-load configuration is better than the non-touching configuration.</li> <li>The structure with shim plate can generate higher output voltage than without shim plate structure.</li> </ul>
G. Yesner et al. [29], 2016	Impact-based	5		400k	2.1m	The impedance value of the transducer and the output power is higher when the resistive load value is higher.
Ali Mohammed abdal-Kadhim et al. [26], 2017	Impact-based		1g	0.7k	53m	Larger output power can be obtained compared to non-prestressed piezoelectric configuration
Xuefeng He et al. [31], 2017	Impact-based	18.4	1g		511 $\mu$	The channel length and having a proof mass will affect the scavenging energy.
Jundong Song et al. [32], 2017	Vibration	34.4	0.5g	6.81M	112.8 $\mu$	The influence of external resistance and additional capacitance are ignored in analytical model can affect the experimental result.
Peyman Firoozy et al. [33], 2017	Vibration	30.19, 30.59	and 1g	0.35 M	6.8m	<ul style="list-style-type: none"> <li>The output power will be increased as the proof mass increased.</li> <li>The maximum output power can be obtained with 40mm length of piezoelectric layer Lp.</li> </ul>
X.D. Xie et al. [34], 2017	Vibration				0.1376	The taper ratios in width and thickness of the cantilever, the width of PZT4 patch, and the width and thickness at the end of the cantilever will affect the RMS output power value.
Ting Tan et al. [35], 2017	Vibration		1g		1.34	The maximal output power value will be obtained when the excitation frequency same with the modified natural frequency.

It was also shown that the smaller the diameter of the shim plate, the higher the output power of the power generator. The power generator was able to harvest 1.5mJ of energy within 120s of vibration time. [32] developed a PVDF-based piezoelectric energy harvester that consists a PVDF bimorph cantilever beam with the steel load mass. The load mass was attached to the end of the beam. The resonant frequency and the maximum stress of the designed model were 34.4Hz and 28.5MPa, respectively. The PVDF-based PEH harvested the output power of 112.8 $\mu$ W and power density of 8.61mW/cm<sup>3</sup>.

[31] developed an impact-based piezoelectric VEH which integrates two bimorphs cantilevers, a rolling steel ball, and two open ends of a guiding channel. The structure is shown in Figure 12. The output efficiency can be increased with

two strategies: (1) increasing the channel length (2) by having a rolling proof mass in the harvester. A maximum output power of one bimorph cantilever of 511 $\mu$ W was produced with an acceleration of 1g at vibration frequency of 18.4Hz. [33] suggested a piezoelectric energy harvester which consists of a unimorph piezoelectric cantilever beam with a tip mass. With the absence of the proof mass, the Matlab and Comsol simulation results showed that the maximum average output power were 0.36mW and 0.37mW, respectively. With the present of the proof mass of 30g, 50g and 70g, the maximum output power were 4.5mW, 5.5mW and 6.8mW, respectively. The higher the proof mass, the higher the maximum output power that will be generated.

[34] designed a piezoelectric energy harvester which consists of a tapered cantilever surface bonded with piezoelectric patches. They found that the larger the taper ratio of thickness or the cantilever width and the PZT4 patch width, the lower the value of RMS of the generated power. The energy harvester generates the RMS output power of 0.1376W. This result is 70 times higher than the uniform counterpart. A hybrid piezoelectric energy harvester by combining the galloping effect was proposed in [35]. A piezoelectric energy harvester with a cantilever beam which consists a substrate layer and two piezoelectric layers that were located on the top and bottom surfaces of the substrate layer and a tip mass was developed. The harvested energy that was generated was 1 W for 0.5g of acceleration and 1.34 W for 1g of acceleration during the excitation frequency was closed to the modified natural frequency of the system.

[36] introduced a dual coupled cantilever based piezoelectric vibration energy harvester (PVEH) system which consists of cantilever beam and piezoelectric cantilever plate. The PVEH with a dimension of  $63.5\text{mm} \times 0.51\text{mm} \times 31.8\text{mm}$  was attached to the steel host structure with dimension of  $450\text{mm} \times 5\text{mm} \times 20\text{mm}$ . The Experimental Modal Analysis (EMA) and Operating Deflection Shape (ODS) analysis were be used for investigating the two non-destructive vibration techniques. The maximum output peak voltage of 6.0Vac is generated during the cantilever beam is vibrated at frequency of 52Hz and it was 33.3% of enhancement in harvested voltage

### III. CONCLUSION

The piezoelectric energy harvesters can generate the output based on vibration, impact-based and bending techniques. Table 1 illustrates the review summary in the context of type of technique to be used, resonant frequency, resistive load, acceleration and produced power. The data in Table 1 show that vibration and impact-based techniques are mainly used compared with the bending technique. This is due to the output power of the bending mode is lower than the vibration and impact-based techniques. Besides that, it is obvious that the cantilever geometry is commonly used for design of the piezoelectric energy harvester. This is because it can generate a large mechanical strain.

[6][8][15][19][32] and [31] used bimorph cantilever beam in piezoelectric energy harvester. This is because the bimorph cantilever's configuration can produce double output power or energy without increasing the dimension of the device. For the impact-based type of piezoelectric energy harvester, applying the instantaneous pulse impact force will generate higher output power without changing the operating resonant frequency. Based on the summary in Table 1, it can be concluded that the highest output power and the lowest output power harvested by the piezoelectric energy harvesters were 1.34W and 34.6nW, respectively.

### ACKNOWLEDGMENT

The first author would like to thank UTeM Zamalah Scheme for the sponsorship scheme.

### REFERENCES

- [1] K. R. Rashmi, A. Jayarama, N. Navin Bappalige, and R. Pinto, "A Review on Vibration Based Piezoelectric Energy Harvesters," *Sahyadri Int. J. Res.*, vol. 3, no. 1, pp. 47–56, 2017.
- [2] Manish And S. Sharma, "Piezoelectric Energy Harvesting In Wireless Sensor Networks: A Review," *Int. J. Electr. Electron. Data Commun.*, vol. 3, no. 1, pp. 18–22.
- [3] Heung Soo Kim, Joo-Hyong Kim, and Jaehwan Kim, "A Review of Piezoelectric Energy Harvesting Based on Vibration," *Int. J. Precis. Eng. Manuf.*, vol. 12, no. 6, pp. 1129–1141.
- [4] P. Chaware, S. Bhusate, A. Bole, and A. B. Nagdewate, "A Review: Power Harvesting From Piezoelectric Materials," *Int. Res. J. Eng. Technol.*, vol. 4, no. 1, pp. 1263–1265.
- [5] H. Li, C. Tian, and Z. D. Deng, "Energy harvesting from low frequency applications using piezoelectric materials," *Appl. Phys. Rev.*, vol. 1, no. 4, p. 41301, 2014.
- [6] S. Roundy *et al.*, "Improving power output for vibration-based energy scavengers," *IEEE Pervasive Comput.*, vol. 4, no. 1, pp. 28–36, Jan. 2005.
- [7] V. R. Challa, M. G. Prasad, and F. T. Fisher, "EH009," in *2008 17th IEEE International Symposium on the Applications of Ferroelectrics*, 2008, vol. 1, pp. 1–2.
- [8] M. Renaud, P. Fiorini, R. van Schaijk, and C. van Hoof, "An impact based piezoelectric harvester adapted to low frequency environmental vibrations," in *TRANSDUCERS 2009 - 2009 International Solid-State Sensors, Actuators and Microsystems Conference*, 2009, pp. 2094–2097.
- [9] J. Hu, J. Jong, and C. Zhao, "Vibration energy harvesting based on integrated piezoelectric components operating in different modes," *IEEE Trans. Ultrason. Ferroelectr. Freq. Control*, vol. 57, no. 2, pp. 386–394, Feb. 2010.
- [10] L. C. J. Blystad and E. Halvorsen, "A piezoelectric energy harvester with a mechanical end stop on one side," in *2010 Symposium on Design Test Integration and Packaging of MEMS/MOEMS (DTIP)*, 2010, pp. 259–262.
- [11] H. Liu, C. J. Tay, C. Quan, T. Kobayashi, and C. Lee, "Piezoelectric MEMS Energy Harvester for Low-Frequency Vibrations With Wideband Operation Range and Steadily Increased Output Power," *J. Microelectromechanical Syst.*, vol. 20, no. 5, pp. 1131–1142, Oct. 2011.
- [12] P. Janphuang, D. Isarakorn, D. Briand, and N. F. de Rooij, "Energy harvesting from a rotating gear using an impact type piezoelectric MEMS scavenger," in *2011 16th International Solid-State Sensors, Actuators and Microsystems Conference*, 2011, pp. 735–738.
- [13] S. m. Chen and J. h. Hu, "Experimental study of a hybrid vibration energy harvesting mechanism," in *2011 Symposium on Piezoelectricity, Acoustic Waves and Device Applications (SPAWDA)*, 2011, pp. 56–59.
- [14] A. Toprak and O. Tigli, "Interdigitated-electrode-based mems-scale piezoelectric energy harvester modeling and optimization using finite element method," *IEEE Trans. Ultrason. Ferroelectr. Freq. Control*, vol. 60, no. 10, pp. 2162–2174, Oct. 2013.
- [15] M. Ferrari, M. Baù, F. Cerini, and V. Ferrari, "Impact-Enhanced Multi-Beam Piezoelectric Converter for Energy Harvesting in Autonomous Sensors," *Procedia Eng.*, vol. 47, no. Supplement C, pp. 418–421, 2012.
- [16] B. Andò, S. Baglio, A. R. Bulsara, V. Marletta, I. Medico, and S. Medico, "A double piezo #x2014; Snap through buckling device for energy harvesting," in *2013 Transducers Eurosensors XXVII: The 17th International Conference on Solid-State Sensors, Actuators and Microsystems (TRANSDUCERS EUROSENSORS XXVII)*, 2013, pp. 43–45.
- [17] M. A. Halim, S. Khym, and J. Y. Park, "Impact based frequency increased piezoelectric vibration energy harvester for human motion related environments," in *The 8th Annual IEEE International Conference on Nano/Micro Engineered and Molecular Systems*, 2013, pp. 949–952.
- [18] N. Jackson, F. Stam, O. Z. Olszewski, R. Houlihan, and A. Mathewson, "Broadening the Bandwidth of Piezoelectric Energy Harvesters Using Liquid Filled Mass," *Procedia Eng.*, vol. 120, no. Supplement C, pp. 328–332, 2015.
- [19] P. Pillatsch, E. M. Yeatman, and A. S. Holmes, "A model for magnetic plucking of piezoelectric beams in energy harvesters," in *2013 Transducers Eurosensors XXVII: The 17th International Conference on Solid-State Sensors, Actuators and Microsystems (TRANSDUCERS EUROSENSORS XXVII)*, 2013, pp. 1364–1367.
- [20] Y. S. Shih, D. Vasic, F. Costa, and W. J. Wu, "Magnetic Stoppers on Single Beam Piezoelectric Energy Harvesting," *Phys. Procedia*, vol. 70, no. Supplement C, pp. 1022–1026, 2015.
- [21] S. Ju and C. H. Ji, "Indirect impact based piezoelectric energy harvester for low frequency vibration," in *2015 Transducers - 2015 18th International Conference on Solid-State Sensors, Actuators and*

- Microsystems (TRANSDUCERS)*, 2015, pp. 1913–1916.
- [22] S. Kaushal, P. K. Dubey, G. Prabhudesai, and B. D. Pant, “Novel design for wideband piezoelectric vibrational energy harvester (P-VEH),” in *2015 19th International Symposium on VLSI Design and Test*, 2015, pp. 1–5.
- [23] L. Van Minh, M. Hara, and H. Kuwano, “Lead-Free (K,Na)NbO<sub>3</sub> Impact-Induced-Oscillation Microenergy Harvester,” *J. Microelectromechanical Syst.*, vol. 24, no. 6, pp. 1887–1895, Dec. 2015.
- [24] D. Alghisi, S. Dalola, M. Ferrari, and V. Ferrari, “Triaxial ball-impact piezoelectric converter for autonomous sensors exploiting energy harvesting from vibrations and human motion,” *Sensors Actuators A Phys.*, vol. 233, no. Supplement C, pp. 569–581, 2015.
- [25] A. M. Abdal-Kadhim and K. S. Leong, “Piezoelectric impact-driven energy harvester,” in *2016 IEEE International Conference on Power and Energy (PECon)*, 2016, pp. 407–411.
- [26] A. M. Abdal and K. S. Leong, “Piezoelectric Pre-Stressed Bending Mechanism for Impact-Driven Energy Harvester,” *IOP Conf. Ser. Mater. Sci. Eng.*, vol. 210, no. 1, p. 12037, 2017.
- [27] K. N. Choi and H. H. Rho, “Continuous energy harvesting method using piezoelectric element,” in *2015 IEEE 2nd International Future Energy Electronics Conference (IFEEC)*, 2015, pp. 1–4.
- [28] X. He, Q. Wen, Y. Sun, and Z. Wen, “A low-frequency piezoelectric-electromagnetic-triboelectric hybrid broadband vibration energy harvester,” *Nano Energy*, vol. 40, no. Supplement C, pp. 300–307, 2017.
- [29] G. Yesner, M. Kuciej, A. Safari, A. Jasim, H. Wang, and A. Maher, “Piezoelectric energy harvesting using a novel cymbal transducer design,” in *2016 Joint IEEE International Symposium on the Applications of Ferroelectrics, European Conference on Application of Polar Dielectrics, and Piezoelectric Force Microscopy Workshop (ISAF/ECAPD/PFM)*, 2016, pp. 1–4.
- [30] A. A. Basari, S. Hashimoto, B. Homma, H. Okada, H. Okuno, and S. Kumagai, “Design and optimization of a wideband impact mode piezoelectric power generator,” *Ceram. Int.*, vol. 42, no. 6, pp. 6962–6968, 2016.
- [31] X. He, K. S. Teh, S. Li, L. Dong, and S. Jiang, “Modeling and experimental verification of an impact-based piezoelectric vibration energy harvester with a rolling proof mass,” *Sensors Actuators A Phys.*, vol. 259, no. Supplement C, pp. 171–179, 2017.
- [32] J. Song, G. Zhao, B. Li, and J. Wang, “Design optimization of PVDF-based piezoelectric energy harvesters,” *Heliyon*, vol. 3, no. 9, p. e00377, 2017.
- [33] P. Firoozy, S. E. Khadem, and S. M. Pourkiaee, “Power enhancement of broadband piezoelectric energy harvesting using a proof mass and nonlinearities in curvature and inertia,” *Int. J. Mech. Sci.*, vol. 133, no. Supplement C, pp. 227–239, 2017.
- [34] X. D. Xie, A. Carpinteri, and Q. Wang, “A theoretical model for a piezoelectric energy harvester with a tapered shape,” *Eng. Struct.*, vol. 144, no. Supplement C, pp. 19–25, 2017.
- [35] T. Tan, Z. Yan, and W. Huang, “Broadband design of hybrid piezoelectric energy harvester,” *Int. J. Mech. Sci.*, vol. 131–132, no. Supplement C, pp. 516–526, 2017.
- [36] S. Y. Khoo, Z. S. Radeef, Z. C. Ong, Y.-H. Huang, W. T. Chong, and Z. Ismail, “Structural dynamics effect on voltage generation from dual coupled cantilever based piezoelectric vibration energy harvester system,” *Measurement*, vol. 107, no. Supplement C, pp. 41–52, 2017.