

# A NEW FAULT DETECTION SYSTEM USING WIRELESS COMMUNICATION – ASSISTED WITH ANALOG RELAYS FOR GRID ELECTRICAL LAMP POLE NETWORK

<sup>1</sup>RANJIT SINGH SARBAN SINGH, <sup>1</sup>WONG YAN CHIEW, <sup>2</sup>BALJIT SINGH SARBAN SINGH, <sup>3</sup>MAYSAM ABBOD

<sup>1</sup>Centre of Telecommunication Research Innovation (CeTRI), Faculty of Electronics and Computer Engineering, Universiti Teknikal Malaysia Melaka (UTeM), Hang Tuah Jaya, 76100 Durian Tunggal, Melaka, Malaysia

<sup>2</sup>Solar Energy Research Institute (SERI), Universiti Kebangsaan Malaysia, 43600 Bangi, Selangor, Malaysia

<sup>3</sup>Department of Electronic and Computer Engineering, College of Engineering, Design and Physical Sciences, Brunel University London, Kingston Lane, Uxbridge, Middlesex UB8 9PH, United Kingdom

E-mail: <sup>1</sup>ranjit.singh@utem.edu.my, <sup>1</sup>ycwong@utem.edu.my, <sup>2</sup>baljit.ukm@gmail.com, <sup>3</sup>maysam.abbod@brunel.ac.uk

## ABSTRACT

This paper explained about the functionality of designed and developed fault detection system for an electrical pole's components. The proposed system aims to accelerate the maintenance process when any component attached to the electrical pole is detected faulty. Hence, the designing and development of the proposed project includes integrating of a fault sensing circuit, control switching and optimization which derives the complete methodology for the proposed system. The fault sensing circuit provides a HIGH output signal when any failure is detected at any component attached to the system. Though the HIGH signal is to detect the fault of a component; this HIGH signal also identifies the respective failed component which provide information and analysis of the failed component. Hence, this newly formulated integrated system is consists of a smart microcontroller which simultaneously process a number of signals from the fault sensing circuitry to enable fast fault managing and reduce the outage time. Integrating the fault detection system which performs as fault detection tasks, fault classification and location, the maintenance team can achieve the fault repairing task in shorter time.

**Keywords:** *Fault Detection System, Fault Sensing Circuit, Continuous Fault Detection, Network Communication System, Fault Detection System*

## 1. INTRODUCTION

Electrical power system is the backbone of any electrical transmission or network and is always prone to cause disruption of power supply. The disruption of power supply may cause destabilization of the entire electrical transmission or network. Therefore, frequent disruption is not only will damage the small network but also the large network as well. And, when the power gets disrupted components connected as a part of the whole system will also damage. Detection of the fault must be prompt and is it important in the viewpoint of economic and operational. In addition, fault should be detected quickly, possible in real

time so that important necessary action can be taken to repair any fault before any major disruption occurs.

When abnormalities occur in the power system transmission or network line, it will always cause damage to any part of the power system whether it must be at the large or small system. When any damage occurs at the large system, the fault can be easily detected due to significant changes on the overall system characteristics such as current, power, power factor, impedance, frequency and voltage [1]. Whereas, when a fault occurs at the customer generation side the fault can be easily seen but not detectable. This also causes difficulty

to accurately locate the fault location, with that also increases the time to repair the fault.

Numerous research work is conducted the field of fault detection or diagnose in electrical power system. Most of the fault detection or diagnose research work in electrical power system is particularly related to one power source distribution system [2] and ring main distribution system [3]. The failure of these kind of power distribution systems are usually the contributor to the failure of parts or components in the distribution systems. Addressing the parts or components of a power system, electrical pole is a subsystem of the distribution system of a power transmission system. Therefore, attached parts or components to a servicing electrical pole are as important as other parts or components in the main distribution system or power distribution system. For now, many of the utility poles are essentially important to auxiliary the power transmission system but also plays an important role in delivering the source of light at the public area at night [4]. Common practice is to send a complaint when any defect in the public street light is notice and this complaint comes from public. Due to this conventional method of reporting, repairing process are often delayed, hence, in turn delayed the maintenance process. With that, the brief review described the important of having street light along the road or walkway is very important to prevent crime and crash reduction [5], the delayed maintenance process will not only causes inconvenience to the public but also causes their safety and security to be at risk [6].

To overcome this problem, this article proposes an automated real-time utility pole fault detection system. The proposed system is integrated as a maintenance system and involves an efficient process which will cause no delay in time when fault or defect occurs at utility pole. Therefore, the proposed automated real-time utility pole fault detection system is comprising of Hardware Fault Detection System (HFDS), Short Message Service (SMS) and Network Communication System (NCS) which will be discuss in the following section. This research paper is organized as followed, Section II discusses about the previous research work, Section III discusses about the design, development and operational of the proposed system, Section IV discusses about the results and discussion and finally in Section V will conclude the research paper.

## 2. LITERATURE REVIEW

The NCS and HFDS is an existing system which will be studied in this section. The NCS study is important to select a reliable communication mode to serve the objective of the proposed system. Therefore, a review of NCS will be summarized and the desirable communication mode will be selected for the proposed system development. Existing systems that integrated with fault detection especially fault detection for utility poles is reviewed and methodological process is discussed.

Prior to start with the literature review understanding the communication protocol between the individual utility poles is necessary. The distance is important to select a suitable communication protocol for fault information delivery when any subsystem of any part of the utility pole is faulty. Typically, the distance between two utility poles are between 38 – 91 meters. In order to select the suitable communication protocol for utility poles, also for the proposed system, the following the characteristic of each communication protocol is studied and compared [7]. The communication protocol is studied based on several parameters, such as bit rate, communication range, number of nodes per master, battery life, linking time, and reliability cost. The study of ZigBee [8], WiFi [9] and Bluetooth [10] shows the 2.4 GHz frequency band communication protocol is used for short range communication. Reviewing the studied parameters ZigBee can communicate at 100 meters range compared to WiFi and Bluetooth. ZigBee also have the lowest power consumption compare to WiFi and Bluetooth, which also helps ZigBee to support large number of nodes per master in a network. Other than that, ZigBee requires the lowest latency which is at 30 milliseconds, faster compare to WiFi and Bluetooth. All the parameters are studied carefully and each parameter important and advantage is mapped with the proposed system. Therefore, after reviewing the parameters ZigBee communication protocol is selected to send faulty signal when any fault is detection in the utility poles.

The NCS approach proposed in the system development also requires a network topology for ZigBee communication protocol to send information from a group of utility poles. Therefore, this section will conduct a short study on the available network topology for ZigBee communication protocol and choose the most suitable network topology for ZigBee communication protocol and the proposed system.

Before considering the network topology, the proposed system has some specific characteristics such as 1) spread over a large geographical area, 2) long thin linear structure, 3) outdoor environment and 4) large number of nodes includes a sink node where the information is gathered. When these characteristics are mentioned, the proposed system is supposedly should operate without any kind of disturbance. Thus, ZigBee can be influenced by some interference, line of sight conditions and obstacles occurrence at the outdoor environment [11][12]. Three apposite network topologies; 1) Tree Topology [13], 2) Star Topology [13],[14] and 3) Mesh Topology [13],[14] can be supported by the ZigBee communication protocol. Among these topologies, start topology has got only one coordinator and a set of end nodes that are directly connected to the coordinator. This allows the coordinator to communicate with the end device but not the end device with the coordinator. Therefore, star topology have limited range and not suitable to be implemented into the proposed system which covers large area [13]. Conversely, the mesh and tree topology have routers that enable multiple routers connection and devices. Thus, this characteristic serves the purpose to connect many utility poles to a controller to control the whole proposed system over a large area. Although the mesh and tree topology are suitable for the proposed system, a review process between both shows that tree topology strength serves the best network topology for the proposed system at large area with proper tree topology configuration.

In the following section, the literature review of street light control system or intelligent street light system existing research work is discussed. In [15], photosensitive control technology and A189S52 microcomputer technology is used to assist the turning ON and OFF of the street lights when a vehicle passing by. A fault detection circuit is integrated into this system to detect faulty lamp. The fault detection circuit is integrated with a feedback resistor, the feedback resistor will sense a high voltage if the lamp is in good condition and zero voltage is the lamp is faulty. In [16], “Hitchhiker” fault detection device is used to detect the streetlights damaged. The “Hitchhiker” is installed into the vehicle and will collect streetlights intensity information without needing to change the setting of the conventional streetlights. The illumination maps (IMAP) data is collected and analyze of which would help to identify the changes in the lighting intensity. An IMAP illumination intensity database for several 2-D locations is collected and compared with a real-time

data. When the vehicle arrived at location P and at Time Z on the same path, illumination intensity is checked and if there are indifferences of illumination intensity, the lamp is reported faulty. In [17], to automatically maintain and reduce the street light power consumption street light monitoring and control system is proposed. A light sensor is placed in all the street lights circuit, if the street light is switched OFF, the sensor placed at every pole is responsible to report the problem status. The problem status is reported through GSM module to the centralized system.

Street light system is connected using an individual controller system or group-based controller system. The group-based controller system is preferred instead of the individual controller system because group-based controller system has an advantage in terms of the costing of the wiring and labor expenses [13]. However, the weakness of group-based controller system is group-based controller system is unable to gather information for individual utility pole [13]. Based on the disadvantage of group-based controller system, one of the aims of the anticipated system is to overcome the weaknesses of individual utility pole information collection of group-based controller system and implementing an appropriate different levels arrangement and hierarchical system. Hence, integrating an individual based controller system at every utility pole and group-based controller information system recorded is used to analyze the utility pole status or condition. While, as for the controller system, all the utility poles information is grouped to perform the group based controlled system to achieve the cost efficiency.

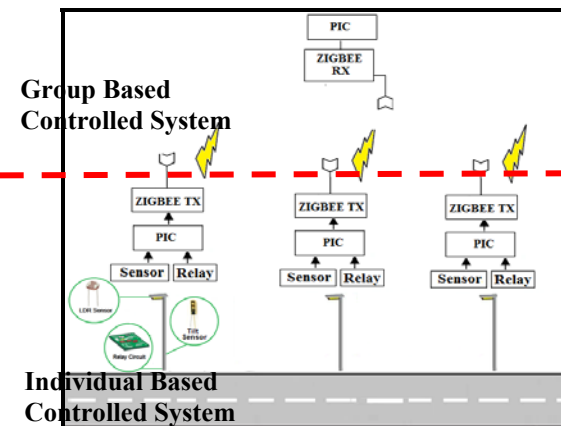

Figure 1: Hierarchical Design of the System

The NCS plays a very important role to transfer the individual based controlled system of every utility pole to the group based controlled

information to gather status of each utility pole. Therefore, before designing and developing the proposed system two important elements must be considered; 1) communication protocol and network topology. As it has been discussed, ZigBee is selected as communication protocol and tree network topology is selected for the proposed system.

### 3. DESIGN AND DEVELOPMENT OF PROPOSED SYSTEM

The design and development of the proposed system is divided into three main subsystems;

- A) fault detection system,
- B) network communication system and
- C) notification system.

Subsystem (A), (B) and (C) are integrated to form a complete system that operates as fault detection system for an electrical utility pole.

#### 3.1 Fault Detection System

The proposed fault detection system is built of three fault detection circuits;

- i) Detection of power failure,
- ii) Detection of faulty lamp,
- iii) Detection of faulty pole.

Fault detection system architecture for electrical utility pole is illustrated in Figure 2. The functionality and operation-ability of each subsystem is described in the following.

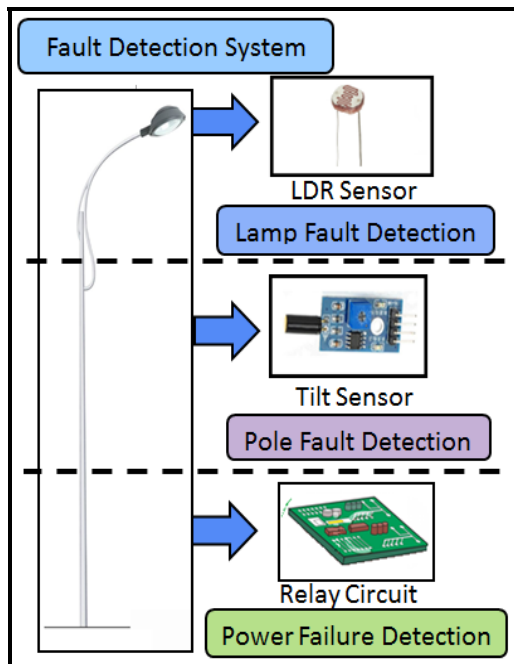

Figure 2: Architecture of Fault Detection System for Utility Pole

#### i) Detection of Power Failure

The power failure detection circuit is integrated in the fault detection system for overall system power failure. The power failure detection circuit comprises of a transistor and SPDT relay. Figure 3 shows the power on status circuit for power detection circuit during the circuit active mode. When the overall system power failed, the failure detection circuit connected to the PIC microcontroller will send a HIGH signal to the PIC microcontroller. When the relay receives a HIGH signal, the relay will switch from Normally Open (NO) to Normally Closed (NC). During this condition, the PIC microcontroller will be connected to 5 Volt and the PIC microcontroller will detect HIGH signal. Now, the PIC microcontroller will always sense HIGH signal. This signal will send notification through GSM on the utility pole status.

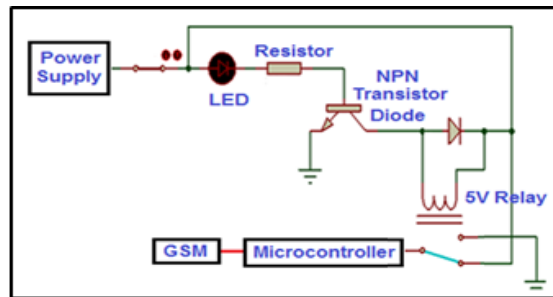

Figure 3: Power ON – Power Detection Circuit

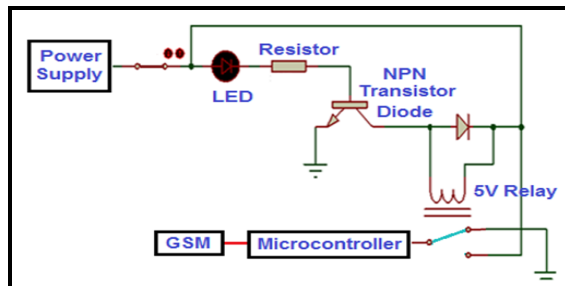

Figure 4: Power OFF – Power Detection Circuit

Power OFF status (inactive mode) of power detection circuit is shown in Figure 4. When this circuit is in inactive mode (open condition), The relay is at Normally Open (NO) and the controller is connected to ground. During this condition, PIC microcontroller always stays at active LOW (LOW signal), hence, no notification is sent through the GSM system.

#### ii) Lamp Fault Detection

The defect of bulb is the most common fault occurs in the street light system. Stressing on the importance of the bulb, the right illumination is

important to make sure there is enough of light source at night at all area. Therefore, to spot the faulty bulb a light sensor detector or Light Dependent Resistor (LDR) is installed nearby to the bulb to measure the bulb illumination intensity during the night. In this case, when the bulb is faulty, no illumination or light intensity is sensed on the light sensor detector or LDR. Hence, the microcontroller will receive a HIGH signal to trigger the GSM module to report a faulty to the maintenance authority.

The light sensor detector or LDR is placed as close as possible for the lamp to optimize the sensitivity of the light sensor detector or LDR and as strategic as possible to not let the light sensor detector or LDR influenced by the environment luminance level. Therefore, when both conditions are satisfied the lamp fault detection circuit will operate as accordingly under the sunlight exposure or during the night when the illumination intensity of the lamp is low.

The sensitivity of the light sensor detector or known as LDR sensitivity need to be configured to sense the bulb illumination for bulb fault detection operation. The LDR is connected to analog to digital (ADC) module of the PIC microcontroller which has got 8 bits lengths of resolution. Hence, analog voltage input of the LDR is measured at  $2^8 = 256$ . Hence, the LDR analog input voltage can be calculated using the Equation (1).

$$V_{ADC} = \frac{LDR_I \times 5}{256} \quad (1)$$

Where,

$V_{ADC}$  = Analog to Digital Conversion Voltage

$LDR_I$  = LDR illumination intensity

$$LDR_I = \frac{V_{ref} \times 256}{5} \quad (2)$$

The resolution level of the LDR for sensing  $V_{ADC}$  voltage is presented using Equation (2).

### iii) Detection of Faulty Pole

The utility poles that hold the street light need to endure various kind of bad conditions such as force strong wind. On that note, it is necessary to integrate the faulty pole detection system as part of the detection system. An accelerometer and tilt

sensor are attached at the utility pole to sense the pole deflection of the pole and faulty notification will be send to the maintenance authority. The pole faulty will be detected fault based on the accelerometer and tilt sensor deflection angle.

Prior setting the required deflection angle of the utility pole, the deflection angle limit of the accelerometer and tilt sensor needs to be investigated. This is to ensure accelerometer and tilt sensor can precisely and accurately measure the deflection angle of utility pole when a faulty pole is detected.

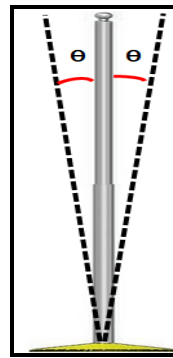

Where  $\theta$  = Critical deflection angle for utility pole that will trigger a HIGH signal to PIC microcontroller

Figure 5: Faulty Pole Deflection Angle.

### 3.2 Network Communication System

The NCS is of the important system integrated in the proposed system. There are two sub-modules in the NCS that need to be understood before integrating into the proposed system. After these two sub-modules are finalized, the selection of a desirable ZigBee Technology is necessary. XBee Series2 ZigBee technology is chosen looking at the ability to cover the range, lower cost and most importantly is to form tree topology communication network.

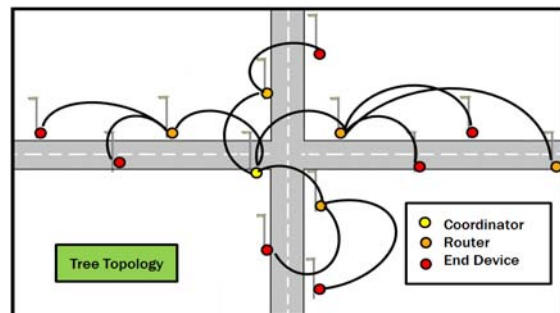

Figure 6: XBee Series 2 Tree Topology Network Communication Structure

XBee Series 2 are integrated at each of the street lights to create the NCS as shown in Figure 6. The proposed NCS has got one coordinator system that communicates via routers to communicate with the

other end devices connected to the routers. The function of the coordinator is to collect the data from all the other end devices or nodes. The gathered information is sent to PIC microcontroller for the system to execute. Considering that, strong communication signal is required to allow strong communication for information sharing (transmitting and receiving).

### 3.3 Global System Mobile Communication Notification

Global System Mobile Communication (GSMC) is used as a communication medium for sending the faulty notification to the authority maintenance team. In the case faulty notification is received, the authority maintenance team will immediately perform repair on the faulty utility. Therefore, this reduces the delay time for maintenance process to be carried out. In short, GSMC is a suitable medium used for immediate faulty notification in order to perform real-time monitoring maintenance system.

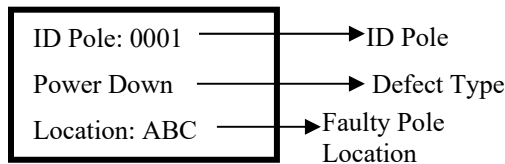

Figure 7: Example of Faulty Notification for Detected Fault

Proposed system uses GSMC communication medium due to having large geographical area that spread the proposed system everywhere. The GSMC has ability to send a Subscriber Identity Module (SMS) which enable the maintenance team to identify the ID of the faulty pole, fault type and faulty pole location. Figure 7 shows the notification example of a faulty utility pole sent when a fault is detected.

### 3.4 Overall System Design and Operation

The design and operation of a completed fault detection system is shown in Figure 8. Every utility pole is attached with the sensors and control relay circuit which responses are captured by the PIC microcontroller. Also, a XBee Series 2 – as transmitter and another XBee Series 2 as receiver is connected at this stage. The XBee Series 2 as receiver circuit attached to PIC microcontroller is located at the receiver side. Both the transmitter and receiver are equally important to effectively detect the fault at real-time and immediately provide a notification to the maintenance team. The receiver system will receive a faulty notification with all the

information as shown in Figure 7, GSMC is activated and SMS that contain all the fault details is sent to maintenance team for quick responds

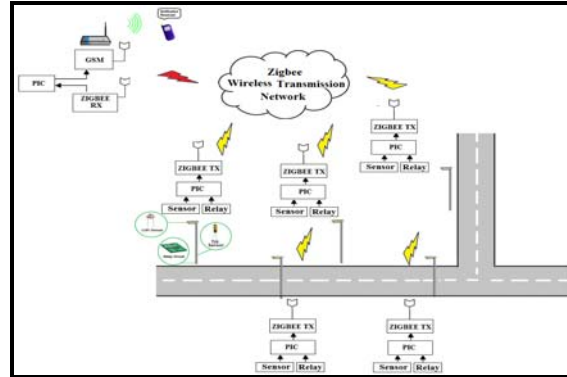

Figure 8: Overall Design and Developed Fault Detection System

Fault detection system operation is illustrated in Figure 9 ID pole 0001 is detected with bulb faulty, hence the illumination of the bulb is low, therefore LDR sensor will sense the low luminance and fault information is received at PIC microcontroller. The bulb faulty information is transmitted via the other utility poles till it arrived at the utility pole with GSMC system to initiate an SMS to the maintenance team.

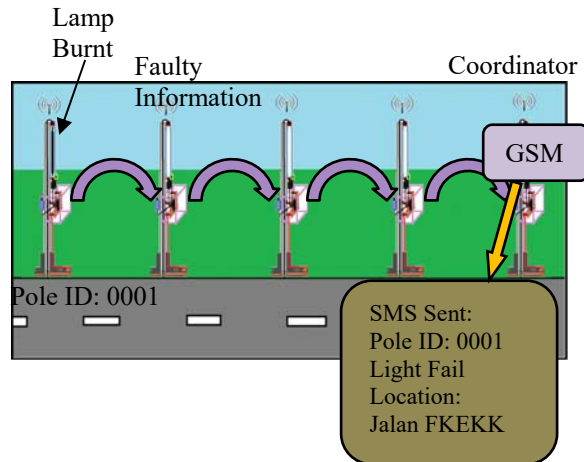

Figure 9: Fault Detection System Operation Illustration

## 4. RESULTS AND DISCUSSION

### 4.1 Hardware Design

The illustration in Figure 10 shows the proposed hardware design of fault detection system. Fig. 10 shows the fluorescent light is installed as light source and fault detection circuit is located inside the box at the utility pole.

The proposed system comprises of microcontroller 5VDC is powered through a step

down voltage from the 240 VAC power source. Also, every and each microcontroller is integrated with three different inputs such as one from control relay circuit which is for detection of power failure, one from accelerometer and tilt sensor for detection of pole deflection and one from LDR sensor for detection of faulty fluorescent light. The tilt and LDR sensor are placed at the utility pole to effectively detect the pole deflection and faulty of fluorescent light as illustrated in Figure 10.

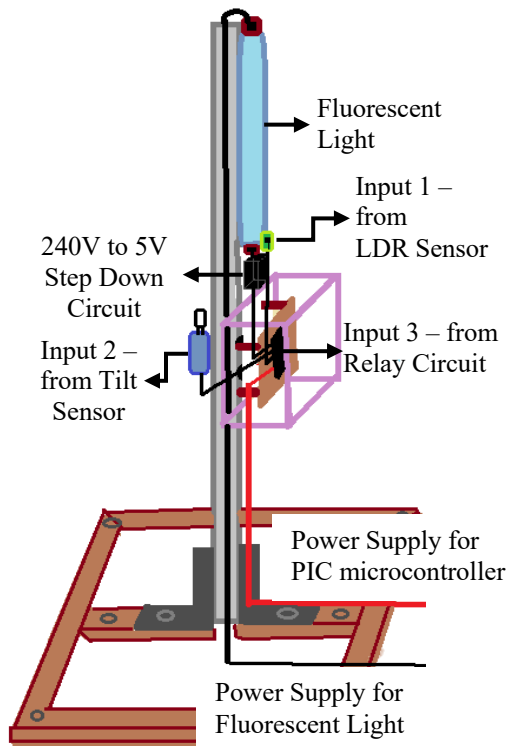
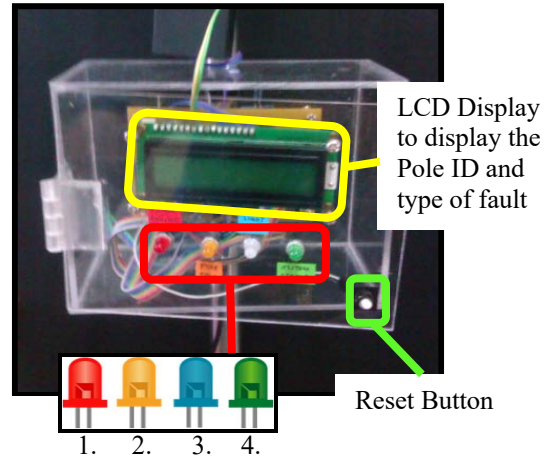

Figure 10: Illustration of Hardware Design of Fault Detection System

The utility pole and microcontroller is powered using different sources. The main 240 VAC power source is step down to 5 Volt before it is used for sourcing the proposed system. Also, each microcontroller is connected with three different inputs such as one from control relay circuit for power failure detection, one from accelerometer and tilt sensor for pole deflection detection and one from LDR sensor for faulty light detection. Referring to the illustration in Figure 10, the tilt and LDR sensors are placed at appropriate location on the utility pole to optimized the system's accuracy.

**i) Failure Detection**

Two transmitter circuits and one receiver circuit as coordinator is integrated as failure detection system.



LED to indicate the status of the utility pole:

- 1. Red: Power Failure
- 2. Orange: Pole Fail
- 3. White: Light Fail
- 4. Green: System Stable

Figure 11: Constructed Hardware of Fault Detection System

**Detection of Power Failure**

Control relay circuit is connected to fault detection system is to trigger the power failure. The control relay circuit is activated HIGH and send HIGH signal to the PIC microcontroller to indicate power has failed at the utility pole.

**Detection of Faulty Bulb**

The bulb fault circuit only activated when the LDR sensor produce voltage which is below the voltage reference set in the program. When the LDR sensor produces voltage reading is below the reference voltage, the light intensity falls on the LDR sensor is too low or the fluorescent light need a change.









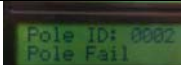

**Detection of Faulty Pole**

The pole deflection occurs only when the deflection exceeded the deflection's angle threshold of the tilt sensor. When the tilt sensor measures a deflection, a HIGH output signal is send to the PIC microcontroller to indicate the deflected pole. In order to avoid false pole deflection detection, the

system is initiated to 5 seconds sensing before a pole deflection faulty is triggered.

The power down, pole deflection, bulb dim or burned and overall system stability status is presented in Table 1. In condition one, Red LED is activated when the system detects the system is power down and the LCD will display the “Power Down” status. Condition two indicate “Pole Deflection, Orange LED is activated. Condition three indicate “Bulb Fail”, Blue LED is activated. The developed system also able to detect two fail condition such as in Table 1. In condition four, Orange and Blue LEDs are activated for “Pole Deflected and Bulb Dim or Burned”. Lastly the developed system also able to detect the overall system failure, such presented in condition five, Green LED is used to indicate this type of failure.

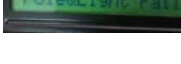
Table 1: System Failure and Stable Conditions.

Condition	LCD Display	LED Display
Power Down		
Pole Deflected		
Bulb dim or burned		
Pole deflected and Bulb dim or burned		
System Stable		

ii) Network Communication System

Transmitter

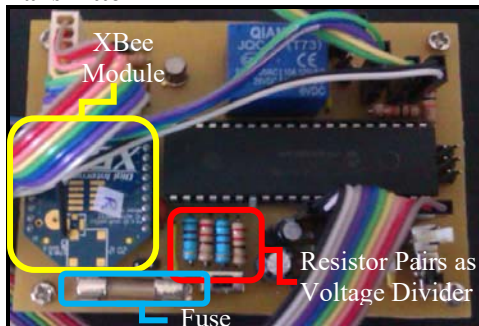

Figure 12: Transmitter Circuit System

Voltage regulator LM1117 is used to convert the 5 Volt voltage supply to 3.3 Volt before connecting

the voltage to XBee Series 2 - ZigBee input voltage. The voltage divider concept is used to convert the 5 Volt voltages of transmitter and receiver from the microcontroller pins before connecting to  $D_{in}$  and  $D_{out}$  pins of XBee Series 2 - ZigBee module.

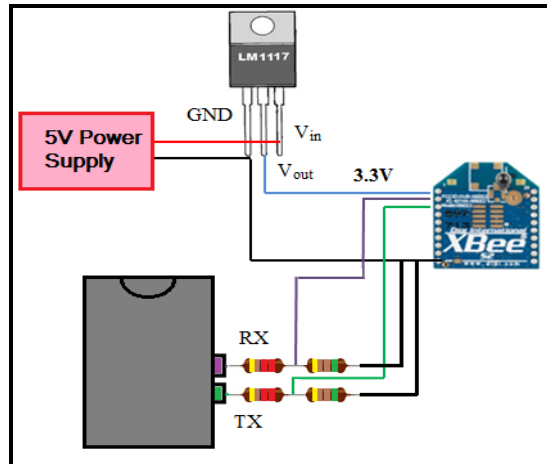

Figure 13: Connection between Microcontroller and ZigBee

Set-up and Configuration of ZigBee Network

In order to operate the Zigbee network communication protocol, XBEE series 2 device was configured. ZigBee network communication protocol is consists of one pair ZigBee devices which acts as a coordinator and router, as illustrated in Figure 6. For the proposed fault detection system, three XBee series 2 modules are used. One is configured as coordinator and the other two are configured as routers.

The XBee Series 2 module configuration and set-up of ZigBee network communication protocol for the fault detection system is presented in Figure 14. Two electrical utility poles are placed at different distance as shown in Table 2. The transmitted data between two electrical utility poles are monitored through the terminal panel in the X-CTU. Observation shows that the transmission distance has been set up at various distances to check on the proposed system requirement. As it has been mentioned at the beginning, the utility poles distance is approximately about 50 meters between two poles. It has been observed, the transmitted data is received at the receiver side very quickly. Even though sometimes there is some small micro seconds delay occurs during the data transmission it can be neglect. This delay usually occurs due to some interferences and obstacles that exist in the outdoor environment sometimes due to bad weather condition.



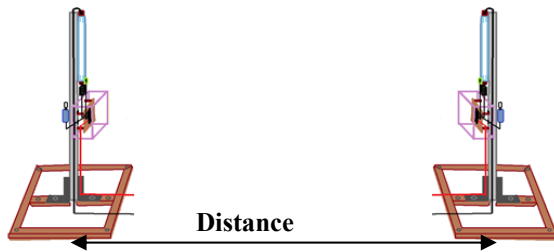

Figure 14: Set-up of XBee Series 2 modules and configuration for ZigBee Network Communication Protocol.

Table 2: Results of Data Transmission between Two Poles at Various Distances

Distance (meter)	Environment	Data Received
5	Outdoor Line-of-Sight	✓
10	Outdoor Line-of-Sight	✓
15	Outdoor Line-of-Sight	✓
20	Outdoor Line-of-Sight	✓
25	Outdoor Line-of-Sight	✓
30	Outdoor Line-of-Sight	✓
35	Outdoor Line-of-Sight	✓
40	Outdoor Line-of-Sight	✓
45	Outdoor Line-of-Sight	✓
50	Outdoor Line-of-Sight	✓

According to the data transmission and receiving results, outdoor line-of-sight environment condition has been used to test the distances and all the data has been received at the receiver part.

Once the data has been received at the receiver side which acts as a coordinator, the received data is decoded. The process of data decoding is important to interpret the faulty information. Then the interpreted data is sent through the GSMC modem to the registered phone numbers. Prior to send a message, a delay should be added in the coding for message sending through GSMC. This is due to the GSMC requires some short time to response received instruction for message sending.

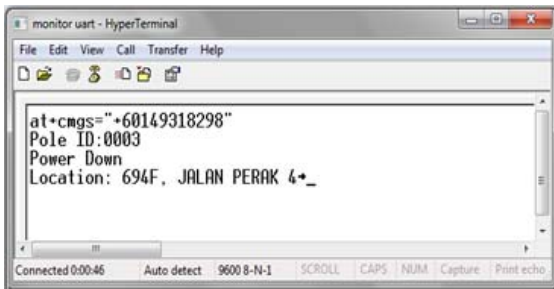

Figure 15: Hyper Terminal UART Communication Output.

Figure 15 shows the tested hyper terminal communication results, therefore connecting the GSMC to the circuit. Table 3 shows power down, pole deflected, bulb dim or burned, and pole deflected and bulb burned or too dim results received as an SMS. The presented results in Table 3 validates the overall system operation and functionality. Three utility poles are tested for fault detection and each utility pole can operate individually as fault detection system for power failure, pole deflection and faulty light (light failed or dimmed). Also, the NCS as coordinator and router performed its task of information sending between the nodes. Looking at the Table 3 results, the router's transmitter circuits performed the faulty information encoding and transmit the data to the targeted destination for a preset distance. Contrary to that, the receiver circuit as coordinator performed information receiving from router's transmitter circuit and decodes the information before sending it to the maintenance authority through the GSMC modem system.

The overall system is tested and working well. For the fault detection, all the three poles can work individually as a stand along utility pole fault detection system for all three types of fault which are power failure, deflected pole and faulty light. Besides that, they can also work well as part of the network communication system that consists of one coordinator, one router and one end device. The transmitter circuits (router and end device) can encode the type of fault and transmit the data to the targeted destination in a desirable range. On the other hand, the receiver circuit (coordinator) can receive the data from the transmitter and decode it.

## 5. CONCLUSION

The role of utility poles is undeniably important to the society as it provides different types of services that become the need in our daily life. However, any type of system is always prone to performance failure, therefore integrating a smart fault detection system would reduce the repair time and increase the safety and public security. With respect to this, the fault detection system has successfully provided a solution specifically to detect the utility poles failure and instantly perform the maintenance whenever it is required. The results also show the effectiveness of the fault detection system to manage the faulty mechanism and optimize the network communication system for information sending. This presents that the faulty utility poles can be located and identified immediately within a short period with a specific pole ID and the location provided. In short, the fault

detection system senses the utility pole immediately and send the faulty information immediately to the authorized maintenance team to organize the maintenance and restoration of the faulty part. The integration of the fault detection system is expected to increase safety and security concern which is caused by the utility pole failure.

#### ACKNOWLEDGMENT

The author(s) wish to thank the Ministry of Higher Education of Malaysia (MOHE), Centre for Telecommunication Research & Innovation (CeTRI), Fakulti Kejuruteraan Elektronik dan Kejuruteraan Komputer (FKEKK), Universiti Teknikal Malaysia Melaka (UTeM), Melaka, Malaysia, Universiti Kebangsaan Malaysia (UKM) and Brunel University London, United Kingdom.

#### REFERENCES:

- [1] A. K. Singh and S. K. Parida, "A Multiple Strategic Evaluation for Fault Detection in Electrical Power System," *Int. J. Electr. Power Energy Syst.*, vol. 48, no. 1, pp. 21–30, 2013.
- [2] W. Al-hasawi, "Proposed Techniques for Identifying Faulty Sections in Closed-Loop Distribution Networks," in *9th WSEAS/IASME International Conference on Electric Power Systems, High Voltages, Electric Machines*, 2009, pp. 1–5.
- [3] S. Vimalraj and D. P. Somasundaram, "Fault Detection, Isolation and Identification of Fault Location in Low-Voltage DC Ring," *Int. J. Adv. Res. Electr. Electron. Instrum. Eng.*, vol. 3, no. 2, pp. 570–582, 2014.
- [4] A. Crosby, "Special Research Topic Report on Current Practice in Utility Distribution Poles and Light Poles," 2011.
- [5] M. S. Rea, J. D. Bullough, C. R. Fay, J. A. Brons, J. Van Derlofske, and E. T. Donnell, "Review of the Safety Benefits and other Effects of Roadway Lighting," 2009.
- [6] J. Yates, "Streetlight Failure Leaves Neighbors in Dark," *tribunedigital-chicagotribune*, 2010. [Online]. Available: [http://articles.chicagotribune.com/2010-09-23/business/ct-biz-0923-problem-gloms-20100923\\_1\\_streetlights-street-lamps-neighbors](http://articles.chicagotribune.com/2010-09-23/business/ct-biz-0923-problem-gloms-20100923_1_streetlights-street-lamps-neighbors). [Accessed: 04-Apr-2016].
- [7] J. Lee, Y. Su, and C. Shen, "A Comparative Study of Wireless Protocols: Bluetooth, UWB, ZigBee, and Wi-Fi," *IECON Proc. (Industrial Electron. Conf.)*, pp. 46–51, 2007.
- [8] A. Lavric, V. Popa, C. Males, and I. Finis, "A Performance Study of ZigBee Wireless Sensors Network Topologies for Street Lighting Control Systems," in *2012 International Conference on Selected Topics in Mobile and Wireless Networking (iCOST)*, 2012, pp. 130–133.
- [9] M. N. Jivani, "GSM Based Home Automation System Using App-Inventor for Android Mobile Phone," *Int. J. Adv. Res. Electr. Electron. Instrum. Eng.*, vol. 03, no. 09, pp. 12121–12128, 2014.
- [10] Xiaoxin Xu, Mingguang Wu, Cheng Ding, Bin Sun, and Jiangwei Zhang, "Outdoor Wireless Healthcare Monitoring System for Hospital Patients based on ZigBee," in *2010 5th IEEE Conference on Industrial Electronics and Applications*, 2010, pp. 549–554.
- [11] "Setting Up the ZigBee Ethernet Gateway." pp. 1–20.
- [12] AMX, "Installation Guide ZigBee Installation Tips." pp. 1–2.
- [13] A. A. Siddiqui, A. W. Ahmad, H. K. Yang, and C. Lee, "ZigBee based Energy Efficient Outdoor Lighting Control System," *Adv. Commun. Technol. (ICACT), 2012 14th Int. Conf.*, pp. 916–919, 2012.
- [14] M. S. Pan and Y. C. Tseng, "ZigBee Wireless Sensor Networks and Their Applications," in *Sensor Networks and Configuration: Fundamentals, Standards, Platforms, and Applications*, 2007, pp. 349–368.
- [15] H. Wu, M. Tang, and G. Huang, "Design of Multi-Functional Street Light Control System based on AT89S52 Single-Chip Microcomputer," *ICIMA 2010 - 2010 2nd Int. Conf. Ind. Mechatronics Autom.*, vol. 1, pp. 134–137, 2010.
- [16] H. Lee, S. Member, and H. Huang, "A Low-Cost and Noninvasive System for the Measurement and Detection of Faulty Streetlights," *IEEE Trans. Instrum. Meas.*, vol. 64, no. 4, pp. 1019–1031, 2015.
- [17] A. L. Saleem, "Street Light Monitoring and Control System," *Int. J. Eng. Tech.*, vol. 1, no. 2, pp. 68–71, 2015.

Table 3: Tested GSMC Received Faulty Information.

Condition	Poles		
	Pole 1	Pole 2	Pole 3
Power Down	Pole ID: 0001 Power Down Location: 123, Jalan Durian Tunggal	Pole ID: 0002 Power Down Location: 677, Taman Bukit Beruang	Pole ID: 0003 Power Down Location: 694F, Jalan Perak 4
Pole Deflected	Pole ID: 0001 Pole Deflected Location: 123, Jalan Durian Tunggal	Pole ID: 0002 Pole Deflected Location: 677, Taman Bukit Beruang	Pole ID: 0003 Pole Deflected Location: 694F, Jalan Perak 4
Bulb dim or burned	Pole ID: 0001 Light Failed Location: 123, Jalan Durian Tunggal	Pole ID: 0002 Light Failed Location: 677, Taman Bukit Beruang	Pole ID: 0003 Light Failed Location: 694F, Jalan Perak 4
Pole deflected and Bulb dim or burned	Pole ID: 0001 Pole&Light Failed Location: 123, Jalan Durian Tunggal	Pole ID: 0002 Pole&Light Failed Location: 677, Taman Bukit Beruang	Pole ID: 0003 Pole&Light Failed Location: 694F, Jalan Perak 4