

## VOLTAGE INSTABILITY ANALYSIS BASED ON ADAPTIVE NEURO-FUZZY INFERENCE SYSTEM AND PROBABILISTIC NEURAL NETWORK

Ahmad Fateh Mohamad Nor<sup>1\*</sup>, Marizan Sulaiman<sup>2</sup>,  
Aida Fazliana Abdul Kadir<sup>3</sup>, Rosli Omar<sup>4</sup>

<sup>1</sup>Green and Sustainable Energy (GSEnergy) Focus Group, Department of Electrical Power Engineering, Faculty of Electrical and Electronic Engineering, Universiti Tun Hussein Onn Malaysia, 86400 Parit Raja, Batu Pahat, Johor, Malaysia.  
<sup>2,3,4</sup>Faculty of Electrical Engineering, Universiti Teknikal Malaysia Melaka, Hang Tuah Jaya, 76100 Durian Tunggal, Melaka, Malaysia.

### ABSTRACT

*This paper presents the application of Adaptive Neuro-Fuzzy Inference System (ANFIS) and Probabilistic Neural Network (PNN) for voltage instability analysis in electric power system. The voltage instability analysis is executed in this research by calculating the values of voltage instability indices. The voltage instability indices used are voltage stability margin (VSM) and load power margin (LPM). Both VSM and LPM are obtained from the real power-voltage (PV) curve and reactive power-voltage (QV) curve. ANFIS is used for predicting the values of voltage instability indices. Meanwhile, PNN is used for classifying the voltage instability indices. The IEEE 14-bus test system has been chosen as the reference electrical power system. Both ANFIS and PNN used in this research are deployed by using MATLAB software.*

**KEYWORDS:** Voltage instability analysis, voltage and load power margin, probabilistic neural network, ANFIS.

### 1.0 INTRODUCTION

Voltage instability has been one of the main reasons of power system blackouts that occurred all over the world (Mobarak, 2015; Morison, Gao, & Kundur, 1993). Voltage stability can be defined as the ability of a power system to keep the voltage at all busses in the system remain steady after the power system is being subjected to a disturbance (Chen, 1996; Kundur et al., 2004; Taylor, 1994). Voltage instability occurs due to the failure of the power system to supply ample power to cover the increased demand of load (Chen, 1996; Kundur et al., 2004). In addition, the power system blackouts caused by voltage instability can be region or nationwide. Voltage instability can affect electrical power interruption to customers as well as industrial and commercial area. Hence, voltage instability problems can lead to economic losses (Chen, 1996).

---

\* Corresponding Email: ahmadfatehmohamadnor@gmail.com

Therefore, the voltage instability analysis should be employed in order to make sure that the voltage level at all busses is at stable state. A number of methods to analyze voltage stability have been proposed, including the most popular method which is the real power-voltage (PV) curve and reactive power-voltage (QV) curve method (Bhaladhare, Telang, & Bedekar, 2013; Gao, Morison, & Kundur, 1992; Morison et al., 1993; Telang & Khampariya, 2015). PV and QV curve is very useful to obtain voltage instability indices that show the distance a load bus towards experiencing voltage instability. These voltage instability indices are voltage stability margin (VSM) and load power margin (LPM) (Basu, Gupta, & Chowdhuri, 2013; Goh et al., 2015; Zhou, Annakkage, & Rajapakse, 2010).

Even though the research regarding voltage instability analysis has been carried out since the late 1960s, there is still room for improvement, especially in terms of accuracy and time execution (Prada, De Souza, & Lafitte Vega, 2015). Thanks to the efficiency of the computers nowadays, the application of Artificial Neural Network (ANN) in voltage instability analysis has been a great help for improving the analysis's accuracy and time execution (Kamalasadan, Thukaram, & Srivastava, 2009). The most popular and widely used ANN configuration is the multilayer perceptron with back propagation (MLBPB) network (Bahmanyar & Karami, 2014; G.C. & H.R., 2014; Goh et al., 2015; Lim, Mustafa, & Jamian, 2015; Mahmoudi & Mahmoudi, 2014). It is called back propagation because the error between the predicted outputs from ANN with the target will be sent back to the hidden layer for weight adjustment.

Previous researches have successfully applied ANN for analysing voltage instability. However, it can be seen in most literature that more attention is given to MLBPB (Ma & El-Keib, 1995; Rahi, Yadav, Malik, Azeem, & Kr, 2012; Zhang, Xu, Dong, Zhang, & Wong, 2013; Zhou et al., 2010). Other ANN architectures are not so oftenly explored. This research will use adaptive neuro-fuzzy inference system (ANFIS) for predicting voltage instability indices. In addition, probabilistic neural network (PNN) will be used for voltage instability indices classification.

## **2.0 METHODOLOGY**

### **2.1 Voltage Stability Margin (VSM)**

Voltage stability margin (VSM) can be defined as the distance between the initial voltage operating point until the voltage critical point. VSM can be classified into two types. The first type is VSM for real power of load (P) or VSM (P). The second type is VSM for reactive power of load (Q) or VSM (Q). Both VSM (P) and VSM (Q) are extracted from the PV and QV curve as shown in Figure 1 (Basu et al., 2013; Nor, Sulaiman, Kadir, & Omar, 2016; Sulaiman & Nor, 2015; Sulaiman, Nor, & Bujal, 2015; Zhou et al., 2010). It is noticeable from Figure 1 that smaller VSM values will cause the distance between the load buses towards voltage instability becomes closer and vice versa. Both VSM (P) and VSM (Q) can be calculated by using Equations (1) and (2), respectively (Basu et al., 2013).

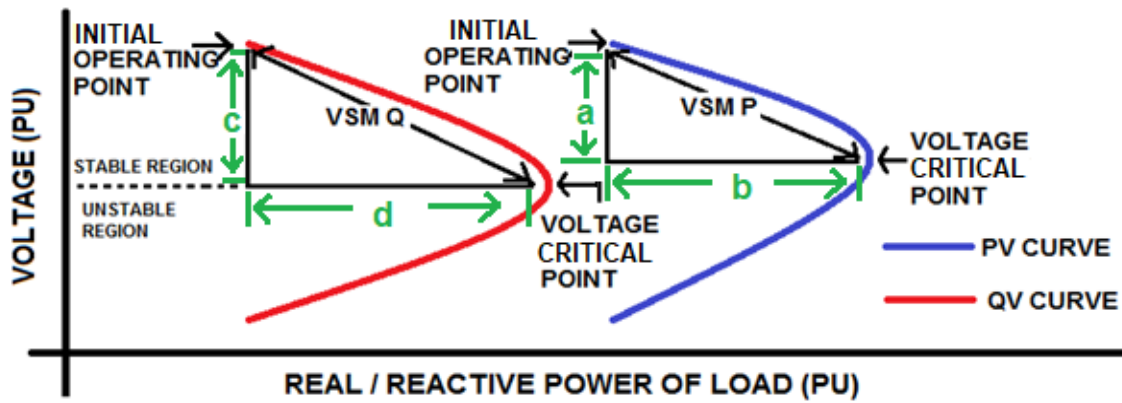

Figure 1: VSM in PV and QV Curves

$$VSM (P) = \sqrt{a^2 + b^2} \quad (1)$$

where,

$$a = V_{P_{initial}} - V_{P_{critical}}$$

$$b = P_{initial} - P_{critical}$$

$V_{P_{initial}}$  is the bus voltage at initial operating point

$V_{P_{critical}}$  is the bus voltage at critical point

$P_{initial}$  is the value of real power of load at initial operating point

$P_{critical}$  is the value of real power of load at voltage critical point

$$VSM (Q) = \sqrt{c^2 + d^2} \quad (2)$$

where,

$$c = V_{Q_{initial}} - V_{Q_{critical}}$$

$$d = Q_{initial} - Q_{critical}$$

$V_{Q_{initial}}$  is the bus voltage at initial operating point

$V_{Q_{critical}}$  is the bus voltage at critical point

$Q_{initial}$  is the value of reactive power of load at initial operating point

$Q_{critical}$  is the value of reactive power of load at voltage critical point

## 2.2 Load Power Margin (LPM)

Similar to VSM, there are two types of load power margin (LPM). The first one is LPM for the real power of load (P) or LPM (P) and the second one is LPM for reactive power of load (Q) or LPM (Q). LPM (P) can be defined as the distance of the real power (P) of load from the initial voltage operating point until the voltage critical point. While LPM (Q) is the distance the distance of the reactive power (Q) of load from the initial voltage operating point until the voltage critical point (Aziz, Saha, & Mithulanathan, 2010). Both LPM (P) and LPM (Q) are also available from the PV and QV curves as shown in Figure 2 (Zhou et al., 2010). LPM (P) is calculated by using Equation (3) (Zhou et al., 2010). LPM (Q) is calculated by using Equation (4) (Aziz et al., 2010).

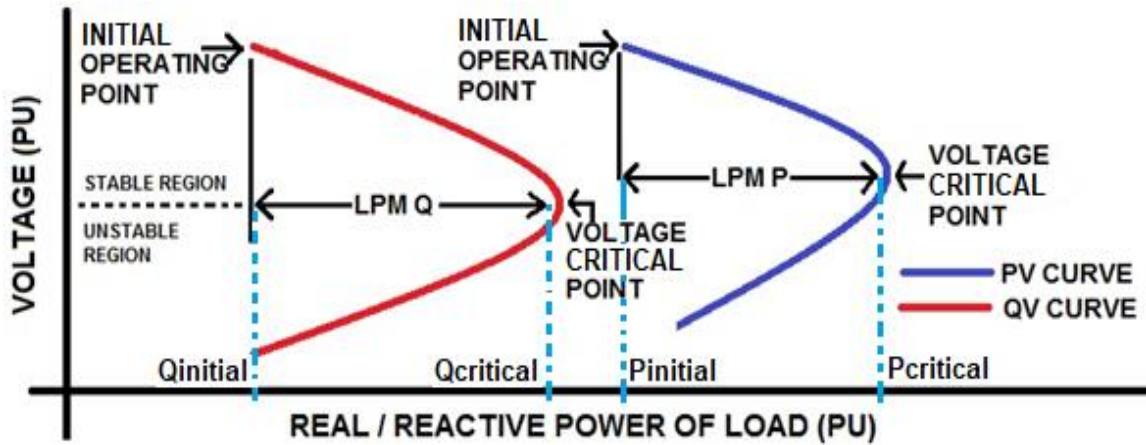

Figure 2: LPM in PV and QV Curves

$$LPM (P) = P_{\text{initial}} - P_{\text{critical}} \quad (3)$$

where,

$P_{\text{initial}}$  is the value of real power of load at initial operating point

$P_{\text{critical}}$  is the value of real power of load at voltage critical point

$$LPM (Q) = Q_{\text{initial}} - Q_{\text{critical}} \quad (4)$$

where,

$Q_{\text{initial}}$  is the value of reactive power of load at initial operating point

$Q_{\text{critical}}$  is the value of reactive power of load at voltage critical point

### 2.3 Adaptive Neuro-Fuzzy Inference System (ANFIS)

Adaptive Neuro-Fuzzy Inference System (ANFIS) is a type of artificial intelligence that combines the algorithm of ANN with Sugeno typed fuzzy logic. In ANFIS system, the membership functions and rules of the fuzzy system are being improved by ANN (Jang, Sun, & Mizutani, 2008; Rajaji, Kumar, & Vasudevan, 2008). Figure 3 (Jang et al., 2008) shows the basic ANFIS structure.

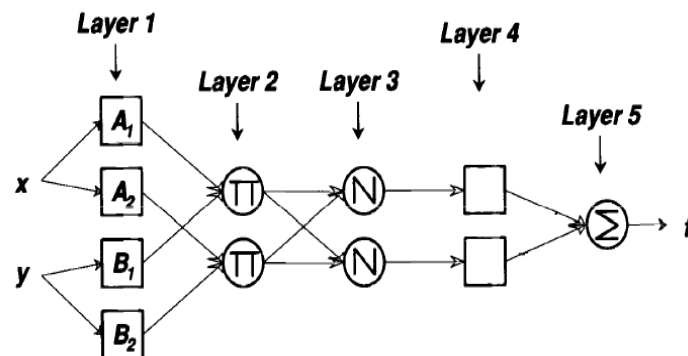

Figure 3: ANFIS Structure

Layer 1 contains the membership functions of the fuzzy system. Layer 2 is the place where the minimum value between two input weights from Layer 1 is selected. The selected

weights are normalized in Layer 3. Layer 4 has the linear functions of the input signals. Finally, Layer 5 sums all the incoming signals to produce the final output (Jang et al., 2008; Rajaji et al., 2008). In this research, ANFIS is used for predicting the target values of VSM (P), VSM (Q), LPM (P) and LPM (Q). ANFIS is executed with the help of MATLAB software. Table 1 shows the inputs and target values used by ANFIS in this research.

Table 1: List of Inputs and Target used in ANFIS

| Target  | Input  |
|---------|--|
| VSM (P) | <ul style="list-style-type: none"> <li>• <math>V_{Pinitial}</math></li> <li>• <math>V_{Pcritical}</math></li> <li>• <math>P_{Pinitial}</math></li> <li>• <math>P_{Pcritical}</math></li> </ul> |
| VSM (Q) | <ul style="list-style-type: none"> <li>• <math>V_{Qinitial}</math></li> <li>• <math>V_{Qcritical}</math></li> <li>• <math>Q_{initial}</math></li> <li>• <math>Q_{critical}</math></li> </ul>   |
| LPM (P) | <ul style="list-style-type: none"> <li>• <math>P_{Pinitial}</math></li> <li>• <math>P_{Pcritical}</math></li> </ul>  |
| LPM (Q) | <ul style="list-style-type: none"> <li>• <math>Q_{initial}</math></li> <li>• <math>Q_{critical}</math></li> </ul>  |

The performance of ANFIS is measured by calculating the mean squared error (MSE). MSE is the average squared difference between calculated and predicted values. The lower value of MSE the better the performance. MSE can be calculated by using the Equation (5) (Bahmanyar & Karami, 2014; G.C. & H.R., 2014; Zhou et al., 2010):

$$MSE = \frac{1}{NTD} \sum_{TD=1}^{NTD} ((Calculated\ VSM/LPM - predicted\ VSM/LPM))^2 \quad (5)$$

where

$NTD$  = the total number of training data

$TD$  = the number of the training data.

## 2.4 Probabilistic Neural Network (PNN)

Probabilistic neural network (PNN) is one of an ANN architecture that is well known for classification purposes (Specht, 1990). Figure 4 shows the basic PNN structure (Seshadrinath & Singh, 2014; Specht, 1990; Sulaiman, Tawafan, & Ibrahim, 2013a, 2013b).

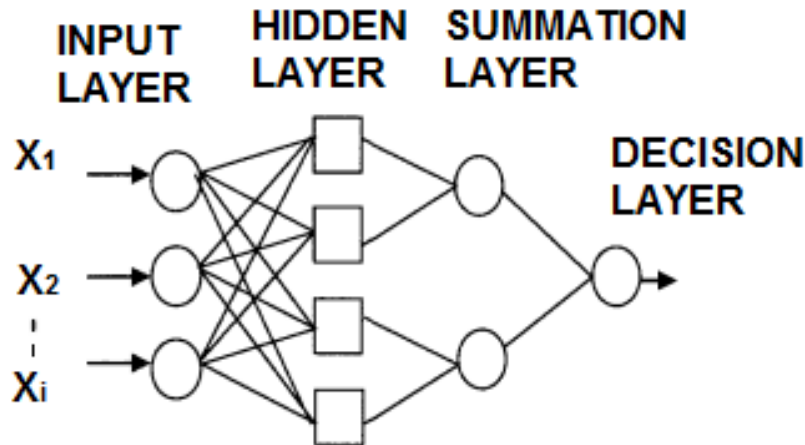

Figure 4: PNN Structure

Figure 4 depicts that PNN is built of four layers. The first layer (input layer) contains the data that need to be classified. Then, the second layer (hidden layer) calculates the distance measure between the input test case and the center of training case represented by the neuron. In the third layer (summation layer), the density function of which class the hidden output layer belongs to is estimated. Finally, at the decision layer, the class that obtains the higher probability in the summation layer are selected (Specht, 1990; Sulaiman et al., 2013a, 2013b).

In this research, PNN is used to classify the target values of VSM (P), VSM (Q), LPM (P) and LPM (Q) into a specified target class. Hence, three classes are set. These classes are labeled Class 1, Class 2 and Class 3. Values below the target VSM or LPM values are classified into Class 1. Meanwhile, the values that are above the target VSM or LPM values are classified into Class 3. Class 2 consists the values that are below the range of  $\pm 0.01$  of the target VSM or LPM values. For example, if the calculated VSM value of a particular bus is 0.5, then other values that are below 0.49 will be classified into Class 1. Similarly, the values that are above 0.51 will be classified into Class 1 and Class 3. MATLAB is used to simulate the PNN.

## 2.5 Generation of Training Data

In order to generate the training data for ANFIS and PNN, the values of real (P) and reactive power (Q) of load at load buses are varied randomly. In this research, the values of P and Q at load buses vary within the range of -0.5 per unit until 1 per unit of the original base values (Bahmanyar & Karami, 2014; Zhou et al., 2010). Approximately of 500 training data were generated for the IEEE 14-bus test power systems. In this research, the training data are divided into 70% for training, 15% for validation and 15% for testing.

## 2.6 IEEE 14-Bus Test Power System

Figure 5 shows the IEEE 14-bus test power system (Pai, 2006). In this test power system, Bus 1 is the slack bus, Bus 2, Bus 3, Bus 6, and Bus 8 are voltage controlled buses, and the rest buses are load buses. Load buses are very important in voltage stability analysis because PV and QV curve are generated at load buses. The load flow analyses are done by using Power World Simulator software version 16.

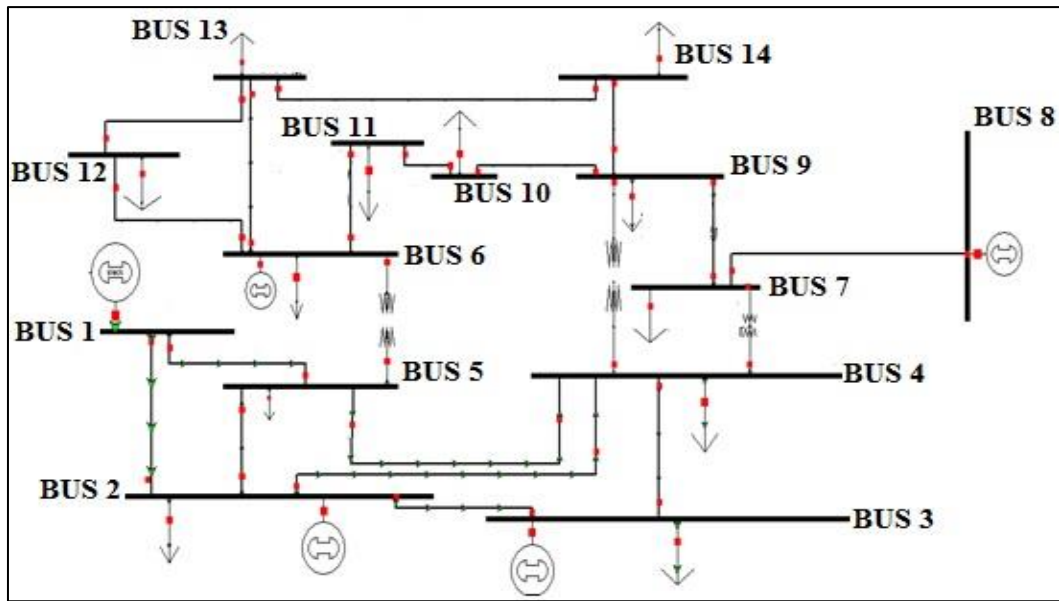

Figure 5: IEEE 14-bus Test Power System

### 3.0 RESULTS AND DISCUSSION

#### 3.1 VSM and LPM

The values of VSM (P), VSM (Q), LPM (P) and LPM (Q) for the load buses in the IEEE 14-bus test power system are calculated. These values will be the target values for ANFIS and PNN. Table 2 displays the result.

Table 2: Voltage Instability Indices for Load Buses in IEEE 14-Bus Test System

| Bus | VSM (P) | VSM (Q) | LPM (P) | LPM (Q) |
|-----|---------|---------|---------|---------|
| 4   | 2.9173  | 2.5501  | 2.9000  | 2.4991  |
| 5   | 3.2961  | 2.7321  | 3.2769  | 2.6828  |
| 7   | 1.6209  | 1.3299  | 1.6000  | 1.2221  |
| 9   | 1.4234  | 1.1710  | 1.4000  | 1.0576  |
| 10  | 1.2315  | 1.0230  | 1.2000  | 0.8962  |
| 11  | 1.1309  | 0.9641  | 1.1000  | 0.8412  |
| 12  | 0.9713  | 0.8699  | 0.8993  | 0.7037  |
| 13  | 1.0222  | 0.9574  | 1.0000  | 0.8357  |
| 14  | 0.8654  | 0.7897  | 0.8000  | 0.6370  |

As can be seen in Table 2, Bus 4 and Bus 5 have the highest values of voltage instability indices. These convey that both Bus 4 and Bus 5 are the most stable load bus in the IEEE 14-bus system. In addition, Table 2 also shows that Bus 14 has the lowest value of voltage instability indices. This means that Bus 14 has the highest tendency towards experiencing voltage instability.

### 3.2 ANFIS Prediction Results

Table 3 and Table 4 list the voltage instability indices prediction values by ANFIS. The values of MSE presented in both tables are from the overall training data.

Table 3: VSM (P) and VSM (Q) for Load Buses in IEEE 14-Bus Test System

| Bus | VSM (P) | ANFIS  | MSE    | VSM (Q) | ANFIS  | MSE    |
|-----|---------|--------|--------|---------|--------|--------|
| 4   | 2.9173  | 2.9172 | 0.0008 | 2.5501  | 2.5502 | 0.0000 |
| 5   | 3.2961  | 3.2961 | 0.0003 | 2.7321  | 2.7320 | 0.0000 |
| 7   | 1.6209  | 1.6209 | 0.0001 | 1.3299  | 1.3297 | 0.0004 |
| 9   | 1.4234  | 1.4234 | 0.0003 | 1.1710  | 1.1698 | 0.0001 |
| 10  | 1.2315  | 1.2311 | 0.0005 | 1.0230  | 1.0228 | 0.0003 |
| 11  | 1.1309  | 1.1309 | 0.0004 | 0.9641  | 0.9632 | 0.0000 |
| 12  | 0.9713  | 0.9711 | 0.0005 | 0.8699  | 0.8700 | 0.0000 |
| 13  | 1.0222  | 1.0222 | 0.0000 | 0.9574  | 0.9604 | 0.0002 |
| 14  | 0.8654  | 0.8650 | 0.0000 | 0.7897  | 0.7899 | 0.0000 |

Table 4: Voltage Instability Indices for Load Buses in IEEE 14-Bus Test System

| Bus | LPM (P) | ANFIS  | MSE    | LPM (Q) | ANFIS  | MSE    |
|-----|---------|--------|--------|---------|--------|--------|
| 4   | 2.9000  | 2.9000 | 0.0000 | 2.4991  | 2.4991 | 0.0000 |
| 5   | 3.2769  | 3.2769 | 0.0000 | 2.6828  | 2.6828 | 0.0000 |
| 7   | 1.6000  | 1.6000 | 0.0000 | 1.2221  | 1.2221 | 0.0000 |
| 9   | 1.4000  | 1.4000 | 0.0000 | 1.0576  | 1.0576 | 0.0000 |
| 10  | 1.2000  | 1.2000 | 0.0000 | 0.8962  | 0.8962 | 0.0000 |
| 11  | 1.1000  | 1.1000 | 0.0000 | 0.8412  | 0.8412 | 0.0000 |
| 12  | 0.8993  | 0.8993 | 0.0000 | 0.7037  | 0.7037 | 0.0000 |
| 13  | 1.0000  | 1.0000 | 0.0000 | 0.8357  | 0.8357 | 0.0000 |
| 14  | 0.8000  | 0.8000 | 0.0000 | 0.6370  | 0.6370 | 0.0000 |

It can be seen from both Table 3 and Table 4 that ANFIS has successfully produced prediction values that are very close to the target values. Not only that, the MSE values are very small. The highest MSE value recorded is only 0.0008. That is to say, ANFIS has the ability to take part in the analysis of voltage instability.

### 3.3 PNN Classification Results

PNN is used to classify the training data of VSM (P), VSM (Q), LPM (P) and LPM (Q) into three classes as explained in Section 2.4. The target class is Class 2, where it contains the values that are below the range of  $\pm 0.01$  of the target VSM and LPM values. The classification results are presented in Table 5 and Table 6. Since the number of generating training data is large, only the training data for the weakest bus (Bus 14) are displayed.



Table 5: VSM (P) and VSM (Q) Classification by PNN

| <b>VSM (P)<br/>Training<br/>Data</b> | <b>Target<br/>Classification<br/>0.86 &lt; Class 2<br/>&lt; 0.88</b> | <b>PNN<br/>Classification</b> | <b>VSM<br/>(Q)<br/>Training<br/>Data</b> | <b>Target<br/>Classification<br/>0.78 &lt; Class<br/>2 &lt; 0.80</b> | <b>PNN<br/>Classification</b> |
|--------------------------------------|--|-------------------------------|--|--|-------------------------------|
| 0.5017                               | 1  | 1                             | 0.5116                                   | 1  | 1                             |
| 0.4014                               | 1  | 1                             | 0.4088                                   | 1  | 1                             |
| 0.3011                               | 1  | 1                             | 0.3058                                   | 1  | 1                             |
| 0.2008                               | 1  | 1                             | 0.2040                                   | 1  | 1                             |
| 0.1004                               | 1  | 1                             | 0.1021                                   | 1  | 1                             |
| 0.0000                               | 1  | 1                             | 0.0000                                   | 1  | 1                             |
| 0.1030                               | 1  | 1                             | 0.1096                                   | 1  | 1                             |
| 0.2043                               | 1  | 1                             | 0.2170                                   | 1  | 1                             |
| 0.3063                               | 1  | 1                             | 0.3263                                   | 1  | 1                             |
| 0.4089                               | 1  | 1                             | 0.4409                                   | 1  | 1                             |
| 0.5136                               | 1  | 1                             | 0.5624                                   | 1  | 1                             |
| 0.6205                               | 1  | 1                             | 0.6997                                   | 1  | 1                             |
| 0.7319                               | 1  | 1                             | 0.7897                                   | 2  | 2                             |
| 0.8654                               | 2  | 2                             | 0.8326                                   | 3  | 3                             |
| 0.9084                               | 3  | 3                             | 0.8554                                   | 3  | 3                             |
| 0.8973                               | 3  | 3                             | 0.8687                                   | 3  | 3                             |
| 0.8888                               | 3  | 3                             | 0.8775                                   | 3  | 3                             |
| 0.8835                               | 3  | 3                             | 0.8838                                   | 3  | 3                             |
| 0.8803                               | 3  | 3                             | 0.8889                                   | 3  | 3                             |
| 0.8786                               | 2  | 2                             | 0.8930                                   | 3  | 3                             |
| 0.8780                               | 2  | 2                             | 0.8965                                   | 3  | 3                             |

It can be understood from Table 5 and Table 6 that PNN has successfully classified all of the generated VSM (P), VSM (Q), LPM (P) and LPM (Q) training data correctly as the target classification. It can be seen clearly that the training data values that have been classified in Class 2 (red color) are within  $\pm 0.01$  of the calculated VSM/LPM Bus 14 values.

Table 6: LPM (P) and LPM (Q) Classification by PNN

| LPM (P)<br>Training<br>Data | Target<br>Classification<br>0.79 < Class 2<br>< 0.81 | PNN<br>Classification | LPM<br>(Q)<br>Training<br>Data | Target<br>Classification<br>0.63 < Class<br>2 < 0.65 | PNN<br>Classification |
|-----------------------------|--|-----------------------|--------------------------------|--|-----------------------|
| -0.5                        | 1  | 1                     | -0.5                           | 1  | 1                     |
| -0.4                        | 1  | 1                     | -0.4                           | 1  | 1                     |
| -0.3                        | 1  | 1                     | -0.3                           | 1  | 1                     |
| -0.2                        | 1  | 1                     | -0.2                           | 1  | 1                     |
| -0.1                        | 1  | 1                     | -0.1                           | 1  | 1                     |
| 0                           | 1  | 1                     | 0                              | 1  | 1                     |
| 0.1                         | 1  | 1                     | 0.1                            | 1  | 1                     |
| 0.2                         | 1  | 1                     | 0.2                            | 1  | 1                     |
| 0.3                         | 1  | 1                     | 0.3                            | 1  | 1                     |
| 0.4                         | 1  | 1                     | 0.4                            | 1  | 1                     |
| 0.5                         | 1  | 1                     | 0.5                            | 1  | 1                     |
| 0.6                         | 1  | 1                     | 0.5973                         | 1  | 1                     |
| 0.7                         | 1  | 1                     | 0.63700                        | 2  | 2                     |
| 0.8                         | 2  | 2                     | 0.63369                        | 2  | 2                     |
| 0.7546                      | 1  | 1                     | 0.61595                        | 1  | 1                     |
| 0.6826                      | 1  | 1                     | 0.59217                        | 1  | 1                     |
| 0.6251                      | 1  | 1                     | 0.56756                        | 1  | 1                     |
| 0.5775                      | 1  | 1                     | 0.54313                        | 1  | 1                     |
| 0.5367                      | 1  | 1                     | 0.52083                        | 1  | 1                     |
| 0.5009                      | 1  | 1                     | 0.49937                        | 1  | 1                     |
| 0.4691                      | 1  | 1                     | 0.47902                        | 1  | 1                     |

#### 4.0 CONCLUSION

This paper has successfully presented the analysis of voltage instability by using the PV and QV curve method. The PV and QV curve method are useful in obtaining VSM (P), VSM (Q), LPM (P) and LPM (Q). These values were very important in determining the bus that has the highest tendency towards voltage instability. The results showed that Bus 14 is the bus with the highest tendency towards voltage instability. Then, ANFIS has been used to predict the values of VSM (P), VSM (Q), LPM (P) and LPM (Q). The results showed that ANFIS were able to produce predicted values that are really close to the target VSM and LPM values. Last but not least, The PNN model used in this research was able to identify which values belong to VSM/LPM and which values that are over or under the target VSM/LPM values. The ability to predict the values of both VSM and LPM is very important so that precautions actions can be taken to prevent voltage collapse.

## ACKNOWLEDGEMENT

The authors are grateful to the Faculty of Electrical and Electronic Engineering, Research Management Centre of Universiti Tun Hussein Onn Malaysia (UTHM) and Universiti Teknikal Malaysia Melaka (UTeM) for the support and beneficial research platform.

## REFERENCES

- Aziz, T., Saha, T. K., & Mithulananthan, N. (2010). Identification of The Weakest Bus in A Distribution System with Load Uncertainties Using Reactive Power Margin. In *20th Australasian Universities Power Engineering Conference (AUPEC)* (pp. 1–6). Christchurch.
- Bahmanyar, A. R., & Karami, A. (2014). Power System Voltage Stability Monitoring Using Artificial Neural Networks with A Reduced Set of Inputs. *International Journal of Electrical Power & Energy Systems*, 58, 246–256.
- Basu, S., Gupta, C., & Chowdhuri, S. (2013). Voltage Stability Margin ( VSM ) and Maximum Loading Point ( MLP ) Of A Multi-Bus System Before and After Compensation. *International Journal of Engineering Research and Development*, 5(7), 30–35.
- Bhaladhare, S. B., Telang, A. S., & Bedekar, P. P. (2013). P-V , Q-V Curve – A Novel Approach for Voltage Stability Analysis. In *National Conference on Innovative Paradigms in Engineering and Technology (NCIPET)* (pp. 31–35). Maharashtra.
- Chen, M. S. (1996). *Energy Systems Research Center*. University of Texas at Arlington.
- G.C., S., & H.R., S. R. (2014). Voltage Stability Assessment in Power Network Using Artificial Neural Network. *International Journal of Advanced Research in Electrical, Electronics and Instrumentation Engineering*, 3(3), 7993–8002.
- Gao, B., Morison, G. K., & Kundur, P. (1992). Voltage Stability Evaluation using Modal Analysis. *IEEE Transactions on Power Systems*, 7(4), 1529–1542.
- Goh, H. H., Chua, Q. S., Lee, S. W., Kok, B. C., Goh, K. C., & Teo, K. T. K. (2015). Evaluation for Voltage Stability Indices in Power System Using Artificial Neural Network. In *Procedia Engineering* (Vol. 118, pp. 1127–1136). Elsevier B.V.
- Jang, J.-S. ., Sun, C.-T., & Mizutani, E. (2008). *Neuro-Fuzzy and Soft Computing: A Computational Approach to Learning and Machine Intelligence*. New Delhi: Prentice-Hall of India Private Limited.
- Kamalasadan, S., Thukaram, D., & Srivastava, A. K. (2009). A New Intelligent Algorithm for Online Voltage Stability Assessment and Monitoring. *International Journal of Electrical Power and Energy Systems*, 31(2–3), 100–110.
- Kundur, P., Paserba, J., Ajjarapu, V., Andersson, G., Bose, A., Canizares, C., ... Vittal, V. (2004). Definition and Classification of Power System Stability. *IEEE Transactions on Power Systems*, 19(2), 1387–1401.

- Lim, Z.-J., Mustafa, M. W., & Jamian, J. J. (2015). Voltage Stability Prediction on Power System Network via Enhanced Hybrid Particle Swarm Artificial Neural Network. *Journal of Electrical Engineering & Technology*, 10(3), 877–887.
- Ma, X., & El-Keib, A. A. (1995). Application of Artificial Neural Networks in Voltage Stability Assessment. *IEEE Transactions on Power Systems*, 10(4), 1890–1896.
- Mahmoudi, S., & Mahmoudi, A. (2014). Water Saturation and Porosity Prediction Using Back-Propagation Artificial Neural Network (BPANN) from Well Log Data. *Journal of Engineering and Technology*, 5(2), 1–8.
- Mobarak, Y. A. (2015). Voltage Collapse Prediction for Egyptian Interconnected Electrical Grid EIEG. *International Journal on Electrical Engineering and Informatics*, 7(1), 79–88.
- Morison, G. K., Gao, B., & Kundur, P. (1993). Voltage Stability Analysis using Static and Dynamic Approaches. *IEEE Transactions on Power Systems*, 8(3), 1159–1171.
- Nor, A. F. M., Sulaiman, M., Kadir, A. F. A., & Omar, R. (2016). Voltage Instability Analysis for Electrical Power System Using Voltage Stability Margin and Modal Analysis. *Indonesian Journal of Electrical Engineering and Computer Science*, 3(3), 655–662.
- Pai, M. A. (2006). *Computer Techniques in Power System Analysis* (Second Edi). New Delhi: Tata McGraw-Hill.
- Prada, R. B., De Souza, L. J., & Lafitte Vega, J. (2015). The Need for Voltage Stability Analysis in Voltage-Controlled Buses. *Electrical Power and Energy Systems*, 68, 252–258. <https://doi.org/10.1016/j.ijepes.2014.12.013>
- Rahi, O. P., Yadav, A. K., Malik, H., Azeem, A., & Kr, B. (2012). Power System Voltage Stability Assessment through Artificial Neural Network. In *International Conference on Communication Technology and System Design* (Vol. 30, pp. 53–60). Gijón.
- Rajaji, L., Kumar, C., & Vasudevan, M. (2008). Fuzzy and Anfis Based Soft Starter Fed Induction Motor Drive for High Performance Applications. *ARPJ Journal of Engineering and Applied Sciences*, 3(4), 12–24.
- Seshadrinath, J., & Singh, B. (2014). Incipient Interturn Fault Diagnosis in Induction Machines Using an Analytic Wavelet-Based Optimized Bayesian Inference. *IEEE Transactions on Neural Networks and Learning Systems*, 25(5), 990–1001.
- Specht, D. F. (1990). Probabilistic Neural Networks. *Neural Networks*, 3(1), 109–118.
- Sulaiman, M., & Nor, A. F. M. (2015). PV and QV Curves Approach for Voltage Instability Analysis on Mesh-Type Electrical Power Networks Using DIGSILENT. *MAGNT Research Report*, 3(6), 36–42.
- Sulaiman, M., Nor, A. F. M., & Bujal, N. R. (2015). Voltage Instability Analysis on PV and QV Curves for Radial-Type and Mesh-Type Electrical Power Networks. *International Review of Electrical Engineering (I.R.E.E.)*, 10(1), 109–115.

- Sulaiman, M., Tawafan, A. H., & Ibrahim, Z. (2013a). Detection of High Impedance Fault Using a Probabilistic Neural-Network Classifier. *Journal of Theoretical and Applied Information Technology*, 53(1), 162–173.
- Sulaiman, M., Tawafan, A. H., & Ibrahim, Z. (2013b). Using Probabilistic Neural Network for Classification High Impedance Faults on Power Distribution Feeders. *World Applied Sciences Journal*, 23(10), 1274–1283.
- Taylor, C. W. (1994). *Power System Voltage Stability*. (N. J. Balu & D. Maratukulam, Eds.) (Internatio). Singapore: McGraw-Hill Inc.
- Telang, B., & Khampariya, P. (2015). Voltage Stability Evaluation Using Modal Analysis. *International Journal of Scientific Research Engineering & Technology (IJSRET)*, 4(4), 408–411.
- Zhang, R., Xu, Y., Dong, Z. Y., Zhang, P., & Wong, K. P. (2013). Voltage Stability Margin Prediction by Ensemble based Extreme Learning Machine. In *IEEE Power & Energy Society General Meeting* (pp. 1–5). Vancouver, BC: IEEE.
- Zhou, D. Q., Annakkage, U. D., & Rajapakse, A. D. (2010). Online Monitoring of Voltage Stability Margin Using an Artificial Neural Network. *IEEE Transactions On Power Systems*, 25(3), 1566–1574.