

Review on controller design in pneumatic actuator drive system

Syamiza Jamian¹, S. N. S Salim², M. N. Kamarudin³, M. Zainon⁴,
M. S. Syed Mohamad⁵, L. Abdullah⁶, M. A. M Hanafiah⁷

^{1,3}Fakulti Kejuruteraan Elektrik, Universiti Teknikal Malaysia Melaka, Malaysia

^{2,4,7}Fakulti Teknologi Kejuruteraan Elektrik dan Elektronik, Universiti Teknikal Malaysia Melaka, Malaysia

^{5,6}Fakulti Kejuruteraan Pembuatan, Universiti Teknikal Malaysia Melaka, Malaysia

Article Info

Article history:

Received Mar 7, 2019

Revised Aug 9, 2019

Accepted Aug 30, 2019

Keywords:

Adaptive controller

PID

Pneumatic actuator

SMC

ABSTRACT

A pneumatic actuator is a device that converts compressed air into mechanical energy to perform varieties of work. It exhibits high nonlinearities due to high friction forces, compressibility of air and dead band of the spool movement which is difficult to manage and requires an appropriate controller for better performance. The purpose of this study is to review the controller design of pneumatic actuator recommended by previous researchers from the past years. Initially, the basic views of the pneumatic will be presented in terms of introduction to the pneumatic actuator and its applications in industries. At the end of this review, discussions on the design of the controllers will be concluded and further research will be proposed along with the improvement of control strategies in the pneumatic actuator systems.

This is an open access article under the [CC BY-SA](https://creativecommons.org/licenses/by-sa/4.0/) license.



Corresponding Author:

Syed Najib bin Syed Salim

Fakulti Teknologi Kejuruteraan Elektrik dan Elektronik

Universiti Teknikal Malaysia Melaka,

Hang Tuah Jaya 76100 Durian Tunggal, Melaka, Malaysia

Email: syednajib@utem.edu.my

1. INTRODUCTION

Pneumatics is an aspect of physics and engineering that use gas or pressurized air to make something move or work. In pneumatics, a valve controls the flow of energy from a pressurized gas, which is often basically compressed air. The device that converts energy from the pressurized gas into movement is known as a pneumatic actuator. Pneumatic actuators are often driven by electric compressors and equipped to create either linear or rotary motion. Figure 1 shows a typical pneumatic system. Pneumatic systems are similar to hydraulic systems; however, the hydraulic systems utilize fluid to control movement and work. The pneumatic framework systems are easier to outline and less difficult to manage compared to hydraulic systems, but the hydraulic systems are equipped for greater pressure: up to 10,000 PSI (pounds per square inch) with hydraulics, contrasted with around 100 PSI with pneumatics.

The rapid development of actuators imposes the pneumatic system into a more significant element to be widely used in the robotics and automation industry. A pneumatic actuator proposes a better alternative than electrical and hydraulic actuators in any application because of its low implementation cost. It also provides the benefits of a clean, safer and easier-to-work environment [1-5]. Throughout the pneumatic history, it was first used in the era of 1900s where pneumatics drives were used in the shipyards and construction sites. Other applications that involved pneumatic actuators were in the active suspension technology for vehicles [6], in the air brake valves of heavy duty vehicles [7], in a robotic system such as Intelligent Soft Arm Robot [8],

conveying system [9] and many more. For the past few years, pneumatic actuator systems were widely applied in the fields of robotics, metallurgy and various industrial processing systems.

Pneumatic actuator becomes an auxiliary actuator in automated material handling tasks due to its special features [10]. However, based on the pneumatic demand for good performance in terms of robustness, accuracy, and stability, the used of these actuators become limited. Previous researchers found that the researches of this area were difficult because of the nonlinearities occurred such as high compressibility of the air, existing frictional force, valve dead zone and mass flow rate parameters [11-14]. As a result of the occurred complexity, the uncertainties parameters of the system were difficult to be obtained and caused a challenging problem in achieving accurate position control. The study on the pneumatic actuators became aggressive due to the increasing demands in the industry during the 1950s where the first development of pneumatics dynamic control was made by Prof. J. L. Shearer in 1956 [15].

The controller design in pneumatic actuators system started in around the year of 1990s and continued to grow in the past years. Previous researchers analysed and expanded the researches in the pneumatic actuator systems and successfully overcame the difficulties that occurred. A control strategy that is always used is proportional integral derivative (PID). The conventional PID is used based on a research and usually combined with other techniques, for example, a neural network, a feedforward controller, a feedback controller and other techniques. Moreover, other controllers used in the pneumatics are sliding mode controller (SMC), an adaptive controller and other synthesis controller.

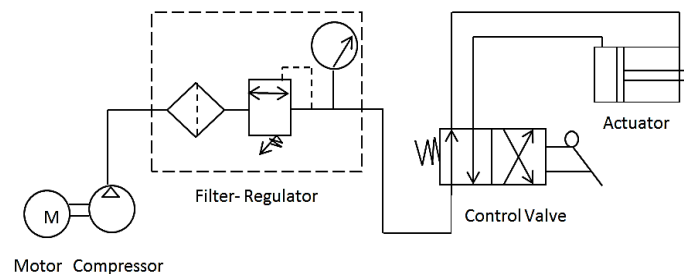

Figure 1. A basic pneumatic actuator system

2. PNEUMATIC ACTUATOR CONTROLLER DESIGN

As stated in the introduction, the pneumatic actuator system is known as a system that comes out with the nonlinearities system model. Therefore, a typical conventional controller is difficult to be implemented in the pneumatic actuator system. It caused the system to be not improvable to achieve better results in performance especially with the variable loads and pressures or other uncertainties.

From previous studies, the modification of the controller was made to improve the nonlinearities that occur in the pneumatic actuator system. In this paper, the review is based on the most popular controllers used in pneumatic actuator system such as, a proportional integral derivatives (PID), a sliding mode controller (SMC), and an adaptive controller. All of these controllers were stated in the previous studies conducted by Huang et al. [16], Jiapeng and Tao [17], Reznik et al. [18], P. Mishra et al. [19], R. R. Sumar, et al. [20], O. Arrieta et al. [21], V. Prabhakaran et al. [22] and Chiang & Chen [23]. The details of the controller design of a proportional integral derivatives (PID), sliding mode controller (SMC), and adaptive controller will be clearly described in the following section.

3. CONTROLLER DESIGN BASED ON PROPORTIONAL INTEGRAL DERIVATIVES (PID)

In 1997, a paper published by [24] made a contribution in pneumatic actuator by proposing a conventional PID controller that accompanied with the friction compensation, bounded integral action and position feedforward that used pulse width modulation (PWM) on-off solenoid valve. This paper proposed these control techniques to control the position but in the pneumatic actuator system, it is always subjected to high friction forces, deadband and deadtime. The parameter of the controller was selected based on the Issermann's method. For the friction compensation, it was formulated based on the Coulomb friction model and it reduced the steady state error to nearly 40%. Then, the bounded integral action was attached to the controller that functions to control the friction force that comes with the piston stroke and finally the position feedforward was to reduce the errors to ramp and S-curves. The proposed controller with the combination of the above-mentioned techniques proved the actuator performance was robust against the changes in the system mass but the rise time or the steady-state accuracy was unaffected.

In the research conducted by [25], the friction compensation once again was applied to the servo-pneumatic system to solve the friction parameters that were difficult to obtain. The proposed method was combined with a PIDVF (PID control with velocity feed-forward and feedback) where the PIDVF was endorsed into a “mixed-reality” environment after the controller was optimized off-line. A PIDVF produced an accurate model and optimized the controller off-line before applying it to a physical system.

Eventually, a modified PID controller with a combination of a nonlinear compensation and acceleration feedback was proposed as indicated by [26]. This study demonstrated that to accomplish an accurate position control, a time delay minimization and position compensation algorithm must be utilized. The analysis was run based on a few setups which are: i) proportional and velocity feedback, ii) proportional, integration, and velocity feedback, and lastly iii) proportional, velocity feedback and feed forward control. The proposed controller produced a better result in the improvement of the system dynamic response compared to the conventional PID controller which the accuracy of the position was shown within 1 mm.

One of the authors in the study [27] reported that the limitations in the pneumatic actuators system is inclusive of the dominant dynamic behavior by the non-linear function. The proportional output feedback controller with saturation was introduced to achieve practical tracking a wide class of reference trajectories by deriving a mathematical modelling and feedback linearization in the position control as a control design method. The proportional feedback force controller straightened up the limitations of the derivatives in the reference signal and disturbance of piston velocity.

The investigation of rapid prototyping of fuzzy controller pneumatic servo-system by [28] towards the positioning control and teaching/play-back control was done by examining the fuzzy logic with PD controller. It used the trapezoid type 25 rules adopted from Mamdani and LuGre model to enhance the simulation result but unfortunately the numerical solution becomes more complex. The formulated fuzzy system was productive, stable and able to avoid disturbances; thus, it can be implemented in any type of pneumatic servo drives without the need to tune the regulator, and signal filtration can be applied or additional operations in the track control and restrict the generated signals.

Besides, author [29] focused on controlling the position of the pneumatic actuator. However, the system has the limitations of high air compressibility and friction force. This research used the classical PID controller where the Ziegler Nichols tuning method was used to tune the K_p , K_i and K_d parameters. Firstly, a P-controller was designed but when it reached the permanent oscillation, it could not be accepted by the positioning system. Then, a PD-controller was introduced to eliminate the problem occur and it yielded a good result in reducing the rise time, and the oscillation did not occur. After that, the PI-controller was tested into the system but unfortunately, the rise time of the system became worse than when the PD-controller was used and, the error of the system became constant. Among all of the tested and simulated controllers, the PID-controller reduced the rise time and error but the occurrence of overshoot increased as the time increased. An analysis of the computed study showed that the system’s behaviour delivered the best satisfaction and produced a model capable to be tested in the simulation to observe the performance. A classical PID also known as an auto-selective classical PID (t-pid) was proposed in this research to provide the accuracy of the position performed in the simulation, and because its cost is very low. However, the proposed controller was complicated to be tuned because it had to be tested in the simulation before being implemented into the real plant.

The conventional PID controller was continuously upgraded in the research conducted by researcher [30] where the tracking position control method was proposed. It was divided into two control loop: i) inner pressure control loop (PID + feedback linearization), and ii) outer position control loop (PID + friction compensation). The friction compensators that augmented with PID had been tested either using neural network and the nonlinear observer. Conventional PID controller usually to be unpredictable and unsatisfactory due to the friction occurs. In order to compensate with the friction, neural network is introduced. For pressure control design, the proportional control valve converts an analog electrical input signal into significant cross sectional opening. While for the controller design of position control by using neural network, the input is the differential pressure and the position as the output. Pressure control where PID is combined with the feedback linearization eliminated the overshoot compared to conventional PID that the overshoot is high. For the friction compensator, either by using neural network or nonlinear observer, the tracking errors which is peak and RMS error were improved even with various amplitudes and frequencies. For the transient part, it can be seen that there are no improvement as the peak error is high when using the neural network and tested by the step input.

Next, the PI controller was used in the study of intelligent pneumatic actuators (IPA) system which requires a better control and accuracy as stated in the study by [31]. The most significant issue in the pneumatic actuators system was the nonlinear attributes, for example, valve dead zone and mass flow rate parameters. In this investigation, on account of the nonlinearities, the PI controller and pole placement feedback controller were introduced. The PI controller controlled the pneumatic system and feedback linearization demonstrated that any single-input single-output (SISO) pneumatic system with a linearization load. In other

parts, input linearization with step type disturbance rejection can quantify disturbance in the pneumatic actuators with static friction. The pole placement used a low order linear approximation for a 2-axes pulse modulation width (PWM) in this study. The pole placement method utilized the self-tuning control that can be adapted with any payload and time-varying parameters. This proposed method is more stable than the PI controller to control the IPA system in terms of transient response and steady-state error.

In a study conducted by [32], it showed how to improve the issue involving the complexity that occurred in procuring the system transfer function precisely. In this study, the cascade PID controller for a practical pneumatic system with good disturbance rejection was introduced. This study provides an identification of the system to build accurate mathematical models of dynamic systems. Particle swarm optimization (PSO) was used as a part of the system identification and control design stages. The cascade PID controller provides advantages to pneumatic system in both position and speed controls. It is because it permits the tracking of the speed profile in the range of speed loop while stopping with high position accuracy. This finding highlighted that the cascade PID structure with PSO tuning provides better transient response and less steady state errors when compared with a single PID.

According to the research by [33], an improvement of a nonlinear PID (NPID) was proposed to control the position of the pneumatic actuator. This study focused on designing the controller so that the actuator can get the desired displacement without overshoot. In a nonlinear PID, there are two parameters need to be specified which are, range of variation (e_{\max}) and rate of variation (α). A modification was made to automatically obtain the parameters to overcome the difficulties of obtaining them. From the previous study, the value of (α) was taken by trial and error method which sometimes the limitation occurred due to the occurrences of speed and chattering in a system. To achieve this goal, a new self-regulation of nonlinear PID (SN-PID) controller with addition of self-regulation function (SNF) was proposed to generate the value of rate variation (α). From the result shown, it can be clearly seen that there is an improvement in the transient part when compared with the nonlinear PID by using different inputs such as step, multistep and random waveform. SN-PID showed a better transient response by a factor of 2.2 times greater than the previous NPID and the robustness of the system was also justified as the proposed controller can handle loads up to 28 kg.

In a subsequent study, an enhanced nonlinear PID (ENPID) once again was proposed in 2015 [34]. The controller consists of two different control strategies, namely multi-nonlinear (MN-PID) controller and self-regulation (SN-PID) controller. Figure 2 shows the structural of MN-PID control strategy. The dead zone compensation was applied to overcome the dead-band of the valve. In addition, the feedforward path also was added to improve the tracking performance. For MN-PID, the fuzzy was used to tune the rate variation of the nonlinear gain, α_x while for SN-PID, it did not use fuzzy to tune the gain, but the gain was generated online through the equation in the SN-PID as stated in the previous study [33]. In this study, both MN-PID and SN-PID performed well in tracking the input trajectories. As a result, the proposed controller, when compared to NPID showed no improvement, but based on the previous study that used a step input, it clearly made an improvement. A variety of amplitude and frequency were used to test the performance of the system with the proposed controller, but did not show a difference which means the proposed control strategies managed to adapt with sudden changes.

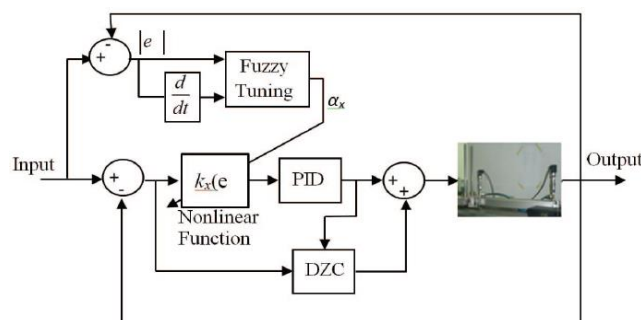

Figure 2. The structural of MN-PID control strategy [32]

Bitauo Yao et al. conducted an experimental investigation on a single pneumatic artificial muscle (PAM) and the hysteresis element was taken into account [35]. An empirical model is any type of computer modelling based on the experimental data that was validated by experiments, then applied to the position control of PAM. PAM is subjected to high nonlinearity and time-variant properties. Therefore, many variable structure control strategies have been proposed by previous researchers. However, in this study

the experiment was compared by using a self-organizing fuzzy controller with model compensation (SOFCMC), a self-organizing controller (SOFC), and a proportional integral derivative (PID) without model compensation. From the result obtained, apparently SOFCMC shows the best result in tracking error compared to SOFC and PID where the error only moved a little which is ± 0.4 mm although the external load was added from 45 N to 85 N. It proved that the robustness of the system is verified and the stability of the controller was maintained. This study also justified that fuzzy controller is the best controller to control the pneumatic artificial muscle.

Furthermore, a study in 2017 by [36] also showed the contribution in the controller design once again is in pneumatic artificial muscle (PAM). This study proposed a conventional PID controller with feed forward control but for this research, it was upgraded with a new adaptive back-propagation (aBP) algorithm. This research proposed the above method because the pneumatic artificial muscle (PAM) is incredibly difficult to control due to the strong nonlinear characteristics and sensitivity towards the working environments such as temperature and other pressure resources. Initially, the inverse neural NARX (INN) model dynamically recognizes all nonlinear elements of the SCARA parallel PAM robot. Then, INN was combined with the conventional PID controller to improve the precision and reduce the steady-state error in the position control. A new adaptive back-propagation was created based on the Sugeno fuzzy system. The introduced control method possesses the capability to learn and update the system automatically and minimize tracking error near to zero. The proposed controller achieved an outstanding control quality, very adaptable and robust without any reference to external disturbances.

As highlighted by [37], this study focused on the pressure tracking control that was applied to the positive and negative pneumatic pressure servo system (PNPPSS). PNPPSS is an important element in the aerospace engineering field where it is used in the aircraft to monitor sealed chamber pressure. However, because of the air compressibility, asymmetry of charging and discharging process, the variation of the parameters due to a leakage that caused the nonlinearities; a control technique of fuzzy proportional integral derivative was introduced and it was accompanied with an asymmetric fuzzy compensator. PID was used because of its simple structure but it has difficulty in obtaining good result owing to the occurrence of nonlinearities. Likewise with fuzzy, which can perform well because it does not require an accurate model but it lacks of adaption to a broad operational range and serious asymmetry. However, the modification was made by adding a fuzzy inference model and an asymmetric fuzzy compensator. This study indicates that the recommended controller overcomes the asymmetric problem and executes better dynamic performance followed by a range of pressure in this field (2-140 kPa).

Research finding by [38] also pointing towards the use of fuzzy PID controller in the pneumatic pressure system. In addition, the fuzzy PID controller was upgraded by adding a fractional order controller and, the proposed controller known as fuzzy fractional-order proportional integral derivative (FFOPID). This study focused on enhancing the robustness of the system due to the load variations and external variations. While the controller was designed, the PID with Ziegler-Nichols tuning method was used to obtain the value of K_p , K_i , and K_d parameters. Then, there are two parameters must be recognize by the fractional-order PID (FOPID) controller: i) integrator order (λ) and ii) differentiator order (μ). The system and derivatives inputs assigned from the fuzzy logic controller (FLC) can be used to perform the scaling factor of the proportional, integral, and derivatives terms. It also improved the performance of the controller using online gain tuning mechanism. The numerical comparison of conventional PID, FOPID, and FFOPID controllers were carried out in the simulation part. From that comparison, it is verified that FFOPID produces the best performance in terms of settling time, overshoot, integral square error, and integral absolute error. It also justified that the system performs well in terms of robustness when the load was added.

Another study by [39] reported that, in order to solve the tracking problem of the servo pneumatic positioning system, the author proposed a nonlinear robust tracking control scheme. The finding highlighted to take into account the pressure, velocity, and position differences of the chambers of pneumatic cylinder as a feedback state. This study achieved success in the simulation, and implemented in the real plant of the pneumatic system and global simulation model. The control strategy was divided into two parts: i) proportional controller as an inner loop to measure the difference of the pressure in the chambers of the pneumatic cylinder, and ii) independent feedback and feedforward (feedforward acts as pre-filter of the reference position trajectory and feedback of the difference between desired and actual state). It was found that the maximum tracking error is approximately 2 mm and the steady-state error is smaller than 1 mm which is better than the previous research's result, 5 mm.

4. CONTROLLER DESIGN BASED ON SLIDING MODE CONTROLLER (SMC)

A sliding mode controller is utilized in most famous controllers that always been used in pneumatic actuator systems. This is because SMC can be implemented in the nonlinear system, therefore previous

researches used this approach to manage the nonlinearities in the pneumatic actuator system as accomplished by J. Song and Y. Ishida [40], Richer and Huzmulu [41], S. R. Pandian et al. [42], Barth et al. [43], G. M. Bone and S. Ning [44], Y. C. Tsai and A. C. Huang [45], Yuan et al. [46], Zhao et al. [47], Chen et al. [48], S. Hodgson et al. [49], A. Estrada and F. Plestan [50], A. Rezoug, B. Tondou, and M. Hamerlain [51], Ayadi et al. [52], and Hidalgo and Gracia [53].

Surveys on the sliding mode controller contributed the information that, it has been used in the pneumatic servo systems since 1997 as reported by [40]. This study came up with a robust sliding mode control strategy by considering the Lyapunov stability theory and the structural properties of a pneumatic servo system. The controller was designed so that the output tracking error cannot be larger than any random small constant, as time, t approach to infinity, strong robustness with respect to large uncertain dynamics can be promised. The controller design commenced with the definition and assumptions from the analysis model of the pneumatic cylinder and equation proved by considering the Lyapunov function. The proposed controller was then applied to the real plant in an experiment to prove the trustworthiness in a practical pneumatic servo system. The implemented load was 30 kg in the forward direction, 100 kg in the backward direction and changed to 100 kg for the forward direction and 30 kg for the backward direction. Both conditions showed that the dynamical tracking error is no larger than 2 mm and the static control precision is approximately 0.2 mm. The control signal was continuous over time. It can be seen that the effects of nonlinear uncertainty factors are endured and a good tracking performance was achieved. However, the control scheme can only be applied for the second-order pneumatic servo system.

In another study by [41], two nonlinear force controllers based on the sliding mode control theory were introduced. The study started with a development of the mathematical model of a pneumatic system, and then the first stage of the controller which required a very complex online computation for the control law was designed. It was followed by the designing of the reduced order of sliding mode controller by neglecting the valve dynamics and time delay. The reduced order controller resulting in the control law becomes simplified. Other researchers tried to control the pneumatic actuators by using a PD and an adaptive controller but that controller was suitable only for low frequencies. However, in this study, the improvement was in the frequencies which a frequency of up to 25 Hz was compared to the previous study's frequency which is only up to 16 Hz. The main focus of this study is to design and test the high-performance force controller suitable for highly demanding applications such as the haptic interfaces. The maximum force tested in this study was 75 N which is suitable for a human operator arm while the maximum frequency used was 25 Hz which can avoid an operator induced oscillation. The study showed both controllers were tested by experiments and simulations. It was found that the reduced controller can only be implemented for a minimum required task such as controlling the shoulder and elbow joints but for any task that requiring high speed and accuracy movements for example wrist and finger joints, it is strongly recommended to use the full order SMC.

In another study presented by [44], the sliding mode control method based on a linear plant (SMCL) and nonlinear plant (SMCN) was implemented to enhance the position tracking control for pneumatic cylinder actuators. The experimental performance in this system was compared both in horizontal and vertical. The motion trajectories are to follow the gravity loading and allow the testing to be performed in various conditions. This research focused on the design and testing of two model-based sliding-mode tracking control algorithms for pneumatic cylinder actuators and a comparison that wasn't conducted in the previous literature was carried out. SMCN performed better in the tracking error, which is 18% better with various operating conditions for both vertical and horizontal compared to SMCL. However, the performance of SMCN is not guaranteed if the complexity is added and the requirement for pressure sensor is higher than in this study.

The sliding mode controller was improved in 2008 by another study in [45]. The improvement materialized when a multiple-surface sliding controller was suggested for the pneumatic servo systems with variable payload and uncertainties. In this proposed controller, the method used is the same type as the backstepping in the [54]'s arrangement, where a sliding controller was designed to minimize the relative degree [55]. The controller design commenced with a few assumptions for the controller to be feasible. The derivation of the MSSC started with the definition of the number of system states sliding surfaces. The result showed the tracking error under MSSC is better than under PID-control but the use of SMC caused chattering effects.

In order to reduce the position error and switching activities as in the study by [49] the system was improved using a seven-mode sliding controller. This study proposed a sliding mode law for a robotic system that utilizes on/off (solenoid) pneumatic actuators. The proposed control design was experimentally justified on a single pneumatic actuator that consists of two chambers driven by four on/off solenoid valves. The sliding mode controller design was initiated with the position-control system where the sliding surface was determined and the stability was analysed by considering the Lyapunov function. However, to apply the controller mode selection involving a seven-mode controller, the current chamber pressures must be intelligent to pick the suitable operating modes. Lastly, controller parameters should be selected to smooth

the motions and reduce the switching activities. Based on the results, the proposed seven-mode controller algorithm is compared with the three-mode sliding mode controller and it reduced the switching activities. The proposed controller also made an improvement in the tracking error which is 0.45 mm.

Other than that, a study of the sliding mode controller with a focus on the switching gain was carried out in 2014 as proposed by [50]. This study focused on a switching gains output feedback controller which is a sample-based on the second order sliding mode. This study highlighted the main common properties of sliding mode (SM) or high order sliding mode (HOSM) control, which are the robustness to the bounded disturbances matched by control and finite approach time. The main advantage of the proposed controller is the reduced number of information where the time derivative of sliding variable is not required.

An improvement to reduce the control valve friction effect was emphasized in a study by [53] in 2017. The controller was proposed in two different approaches. The first approach was to control the flow of the plant using a valve as a control element which integrates SMC under an external topology using different sampling times (1 ms, 10 ms, and 100 ms). The second approach was the integration of SMC under an internal topology. In this approach, SMC acts as a slave control loop for the valve position stem while PI controller acts as a master control loop in regulating the flow. The experimental result showed that the integrated SMC under the external topology without a state observer with the sampling times of 1ms and 10 ms produced the best result. In contrast, the use of 100 ms sampling times yielded a better result but chattering problem occurred. Nevertheless, this integrated SMC is suitable for a very high-performance control loop and in addition, the implementation cost is also high.

5. CONTROLLER DESIGN BASED ON ADAPTIVE CONTROLLER

In a subsequent study, the author must deal with the same previous problem as the pneumatic servo position control system has the typical characteristics of nonlinearity and time-varying [56]. A new improvement to the friction compensation was made in this study with a focus to enhance the accuracy of pneumatic servo position control systems. The proposed controller was an adaptive fuzzy-PD. The fuzzy controller controls the displacement of a pneumatic servo system that can arrive at a set point with a reduced overshoot, but to achieve this goal, the adaptive compensation must be designed and combined with a conventional fuzzy controller to compensate the friction. In the experimental result, it is clear that the settling time and steady state error under a constant load were obtained for less than 1 s and 0.3 mm with a reduced overshoot. It should be noted that this technique was not tested on the system under variations of load.

Next, the model reference adaptive controller (MRAC) that focused on the compensating friction and payload uncertainties in a servo pneumatic actuation system was mentioned by [57]. Based on this research, the most common uncertainties occurred in the mechanical system were friction and payload. Normally, previous researches did not take into account the friction that occurred in the system. The friction occurred when the piston and rod seal contacted during the sliding in the pneumatic actuator system. The position control performance in this paper was compared with its works on the motor systems while the previous research used other three adaptive controllers such as backstepping adaptive controller, self-tuning adaptive controller, and model reference adaptive controller that proposed for a permanent magnet linear synchronous motor position control. From that comparison, it showed that pneumatic actuators can produce accurate position control such as electrical systems. Firstly, the friction model was selected based on the Gaussian exponential static friction model which captures three friction phenomena; Coulomb, viscous and Stribeck friction. Then, the sliding mode controller was designed to maintain the robust, stability, and good performance of a nonlinear control system with nonlinear modelling inaccuracies and MRAC was designed for the adaptive friction compensation. From that proposed control method, the steady-state positioning accuracy was less than 0.05 mm for a 60 mm step input with a rise time of about 200 ms.

Y. Shtessel et al. [58] stated, a novel super-twisting adaptive sliding mode control law was derived using Lyapunov function technique. The proposed method used a dynamically adapted control gain that ensures the establishment in a finite time of a real second order sliding mode. The experimental result showed a reduction in the gain during some of the time intervals that affect the accuracy of tracking performance. Based on the study in 2015 by [59], to control the position of an anthropomorphic robotic hand, an adaptive backstepping algorithm was proposed. The proposed algorithm was a conventional PID controller combined with an adaptive backstepping position control. The performance of the designed controller was assessed only in a simulation test. This study showed that the settling time of 0.2 second with maximum error of only 0.2° was achieved.

In another research, [60] revealed that to control the speed of a vane-type air motor (VAM) pneumatic servo system, an adaptive high-precision controller must be developed. An adaptive dynamic sliding mode controller (ADSMC) was proposed to achieve this objective. The control method for VAM is divided into two categories; the first category is a model-free control such as fuzzy control and PID control. At this stage, it can

derive control signal without realizing the exact model of the system. The second category is a model-based control which includes the backstepping and sliding mode control. The control system was used to control the pressure difference of the output torques. The presence of air in the chamber and friction causes difficulty in implementing parameters in the control laws. It affected the steady state error and caused poor robustness in the VAM application. A few controllers were used as comparisons to the proposed controller. The proposed ADSMC experimental result clearly showed that it improved the speed-tracking performance, better than PID, proportional integral derivative-neural network (PIDNN), fuzzy-neural network (FNN), and proportional integral derivative-fuzzy-neural network (PIDFNN).

6. PERFORMANCE OF THE CONTROLLER

The performance from the previous studies based on three types of controllers that are always used in pneumatic actuator can be illustrated as in Figures 3, 4 and 5. By referring to these Figure, indices a, b, c, d, e represents the performance of the controller achievement in the previous studies. For example, PID controller combined with friction compensator, bounded integral and feedforward give the better performance in term of accurate and transient where it represents as: [a] Next, PID merged with nonlinear compensator and feedback gives the performance of accurate, [b] represents it. For index [c], robust and precise performance happened when global sliding mode controller is implemented into the system. An improvement of NPID with MN-function and SN-function give the performance of [d] which is robust, accurate and fast response. Lastly, [e] appointed accurate and robust. An example to this performance is in adaptive controller when MRAC is applied. The performance of the controllers in Figures 3, 4 and 5 can be summarized as in Table 1.

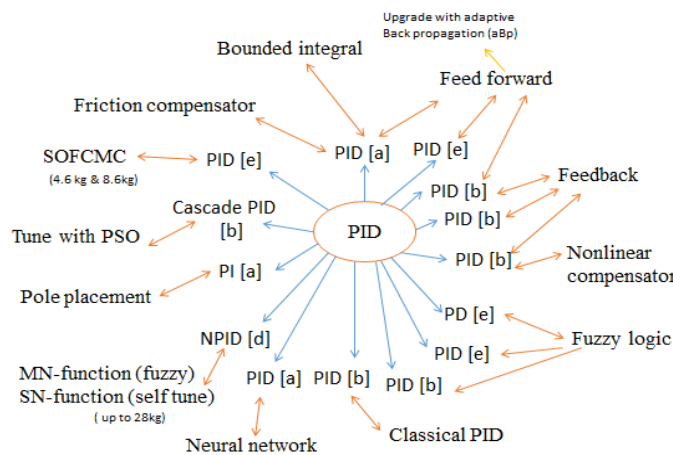

Figure 3. The performance of PID controller in pneumatic actuator

Table 1. Performance of the controller achievement

Index	Performance
a	Accurate and transient
b	Accurate
c	Robust and precise
d	Robust, accurate, and fast response
e	Accurate and robustness

Here are the recommendations that could be developed in future studies to make improvements in the pneumatic field. Many researchers are only concerned with how to get a good steady state performance but only a few of studies aimed at improving transient performance to achieve fast response or to prevent overshoot. Therefore, future studies can improve the method to achieve a good performance in both tracking performance and transient response. In addition, the robustness of the system can be improved once again by increasing the load weight such as more than 30 kg by proposing a new combination technique into the system. This phenomenon would have been more successful if the robustness of the system is achieved along with the accuracy and stability.

Next, the tracking performance studies using sinusoidal and S-curve did not show an improvement when the comparison was made with another existing method such as N-PID controller. It happens because

there are some weaknesses in the proposed method to compensate the dead zone in the valve as it is known that it is one of the nonlinearities occurrences in a pneumatic actuator system. For future research, an adaptive technique can be applied to the dead zone compensator. To conclude, all improvements to be proposed in future studies must comply with the requirements of the industry and must be able to improve the system as well as meet the growing demand in the pneumatic actuators field.

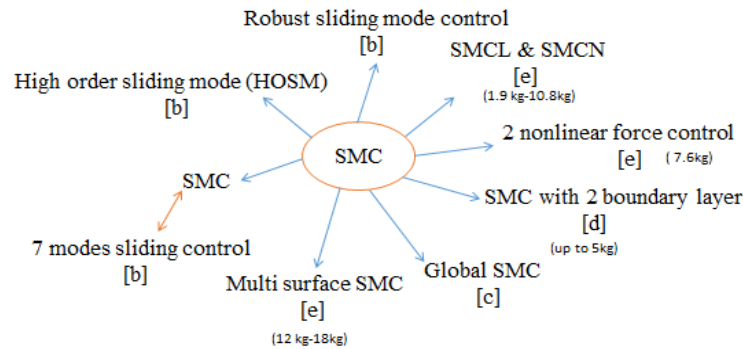

Figure 4. The performance of the sliding mode controller in pneumatic actuator system

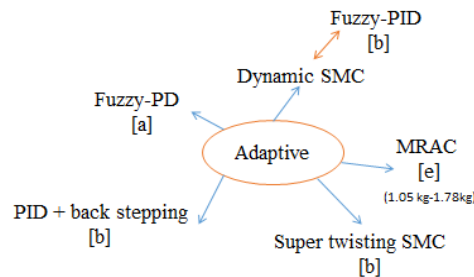

Figure 5. The performance of the adaptive controller in pneumatic actuator system

7. CONCLUSION

Based on previous studies, the most common problem in pneumatic actuator system is caused by the nonlinearities of the system such as the high compressibility of air, frictional force, deadtime and deadband. In addition, based on the demand of the pneumatic to obtain good performances in terms of the robustness, accuracy, and stability, the use of these actuators becomes limited. Previous researchers have produced many controllers to solve those problems. The most widely used controllers in the pneumatic actuator system are proportional integral derivatives (PID), sliding mode controller (SMC), and adaptive controller. The conducted literature review showed that in the 1990s, researches in these actuators increased due to many control strategies were introduced and applied into the system such as PID control, PD control, sliding mode control, and adaptive control. Then, the study in this field became more aggressive when the researchers emerged with many advanced control strategies in the early 2000s. However, most of the recommended control strategies studies involved complex parameters and tied with the complicated mathematical equations. For that reason, over the past few years, most of the researchers still holding to the control loops based on proportional integral derivatives (PID) controller because of its simplicity and easy to understand. This is the most significant option available in the industry of control application due to its simple structure as it has only three parameters to be considered even it might face difficulty in dealing with the highly nonlinear systems.

ACKNOWLEDGEMENTS

This research is supported by Universiti Teknikal Malaysia Melaka (UTeM) and Universiti Teknologi Malaysia (UTM) through Short Term – High Impact grant scheme (PJP-HI) with reference number of PJP/2017 FTK/HI/S01535 and Research University Grant (GUP) Tier 1 vote no. Q.J130000.7123.00H36. Authors are grateful to UTeM and UTM for supporting the present work. A special thanks also goes to the Ministry of Higher Education.

REFERENCES

- [1] S. B. M. Noor, et al., "Design of combined robust controller for a pneumatic servo actuator system with uncertainty," *Sci. Res. Essays*, vol. 6, no. 4, pp. 949-965, 2011.
- [2] T. D. C. Thanh and K. K. Ahn, "Nonlinear PID control to improve the control performance of the pneumatic artificial muscle manipulator using neural network," *Mechatronics*, vol. 16, no. 9, pp. 577-587, Nov 2006.
- [3] J. F. Carneiro and F. G. De Almeida, "A high-accuracy trajectory following controller for pneumatic devices," *Int. J. Adv. Manuf. Technol.*, vol. 61, pp. 253-267, 2012.
- [4] S. Aziz and G. Bone, "Automatic tuning of an accurate position controller for pneumatic actuators," *Proceedings. 1998 IEEE/RSJ Int. Conf. Intell. Robot. Syst. Innov. Theory, Pract. Appl. (Cat. No.98CH36190)*, vol. 3, pp. 1782-1788, 1998.
- [5] B. Lu, et al., "Modeling and control of the pneumatic constant pressure system for zero gravity simulation," *2008 IEEE/ASME International Conference on Advanced Intelligent Mechatronics*, pp. 688-693, 2008.
- [6] R. Rosli, et al., "Active suspension system for passenger vehicle using active force control with iterative learning algorithm," *WSEAS Trans. Syst. Control*, vol. 9, pp. 120-129, 2014.
- [7] F. Bu and H. S. Tan, "Pneumatic brake control for precision stopping of heavy-duty vehicles," *IEEE Trans. Control Syst. Technol.*, vol. 15, pp. 53-64, 2007.
- [8] J. Schröder, et al., "Improved Control of a Humanoid Arm Driven by Pneumatic Actuators," *Int. Conf. Humanoid Robot*, pp. 1-20, 2003.
- [9] B. E. Student, et al., "Electro-Pneumatic Lift and Carry Conveying System," *International Journal of Science Technology & Engineering*, vol. 2, no. 10, pp. 904-907, 2016.
- [10] M. F. Rahmat, et al., "Review on Modeling and Controller Design," *Int. J. Smart Sens. Intell. Syst.*, vol. 4, No. 4, pp. 630-661, Jan 2011.
- [11] B. Taheri, et al., "Design of robust nonlinear force and stiffness controller for pneumatic actuators," *2012 IEEE 51st IEEE Conference on Decision and Control (CDC)*, Maui, HI, pp. 1192-1198, 2012.
- [12] S. C. Hsu and C. Y. Lin, "Periodic motion control of a heavy duty pneumatic actuating table using low-cost position sensors and hybrid repetitive control," *IEEE Int. Symp. Ind. Electron.*, pp. 1-6, 2013.
- [13] G. M. Bone, et al., "Position control of hybrid pneumatic-electric actuators using discrete-valued model-predictive control," *Mechatronics*, vol. 25, pp. 1-10, 2015.
- [14] K. Hamiti, et al., "Position control of a pneumatic actuator under the influence of stiction," *Control Engineering Practice*, vol. 4, no. 8, pp. 1079-1088, 1996.
- [15] S. Cai, et al., "Cylinder position servo control based on fuzzy PID," *J. Appl. Math.*, vol. 2013, pp. 1-10, Nov 2013.
- [16] C. Q. Huang, "Robust Nonlinear PID Controllers for Anti-windup Design of Robot Manipulators with an Uncertain Jacobian Matrix," *Acta Autom. Sin.*, vol. 34, no. 9, pp. 1113-1121, 2009.
- [17] J. Tong and T. Yu, "Nonlinear PID control design for improving stability of micro-turbine systems," *2008 3rd Int. Conf. Electric Utility Deregul. Restruct. Power Technol.*, pp. 2515-2518, 2008.
- [18] L. Reznik, et al., "PID plus fuzzy controller structures as a design base for industrial applications," *Eng. Appl. Artif. Intell.*, vol. 13, no.4, pp. 419-430, 2000.
- [19] P. Mishra, et al., "A novel intelligent controller for combating stiction in pneumatic control valves," *Control Eng. Pract.*, vol. 33, pp. 94-104, December 2015.
- [20] V. Prabhakaran, et al., "Design of a controller for the pneumatic flow control valve and pressure regulation for application related to pneumatically powered orthosis," *2016 International Conference on Information Communication and Embedded Systems (ICICES)*, Chennai, pp. 1-5, 2016.
- [21] R. R. Sumar, et al., "Computational intelligence approach to PID controller design using the universal model," *Inf. Sci. (Ny)*, vol. 180, no. 20, pp. 3980-3991, 2010.
- [22] O. Arrieta, et al., "PID autotuning for weighted servo/regulation control operation," *J. Process Control*, vol. 20, no. 4, pp. 472-480, 2010.
- [23] C. J. Chiang and Y. C. Chen, "Neural network fuzzy sliding mode control of pneumatic muscle actuators," *Eng. Appl. Artif. Intell.*, vol. 65, pp. 68-86, October 2017.
- [24] R. B. Van Varseveld and G. M. Bone, "Accurate Position Control of a Pneumatic Actuator Using On / Off Solenoid Valves," in *IEEE/ASME Transactions on Mechatronics*, vol. 2, no. 3, pp. 195-204, 1997.
- [25] A. Saleem, et al., "Mixed-reality environment for frictional parameters identification in servo-pneumatic system," *Simul. Model. Pract. Theory*, vol. 17, no.10, pp. 1575-1586, 2009.
- [26] J. Wang, et al., "A practical control strategy for servo-pneumatic actuator systems," *Control Eng. Pract.*, vol. 7, no. 12, pp. 1483-1488, 1999.
- [27] A. Ilchmann, et al., "Pneumatic cylinders: Modelling and feedback force-control," *Int. J. Control*, vol. 79, no. 6, pp. 1-21, 2005.
- [28] J. E. Takosoglu, et al., "Rapid prototyping of fuzzy controller pneumatic servo-system," *Int. J. Adv. Manuf. Technol.*, vol. 40, no. 3, pp. 349-361, 2009.
- [29] M. Papoutsidakis, et al., "Modeling and Simulated Control of Non-Linear Switching Actuation Systems," *8th International Conference on System Science and Simulation in Engineering*, pp. 97-102, October 2009.
- [30] H. K. Lee, et al., "A study on tracking position control of pneumatic actuators," *Mechatronics*, vol. 12, no. 6, pp. 813-831, July 2002.
- [31] A. A. M. Faudzi, et al., "Controller design for simulation control of Intelligent Pneumatic Actuators (IPA) system," *Procedia Eng.*, vol. 41, pp. 593-599, 2012.
- [32] A. Saleem, et al., "Identification and cascade control of servo-pneumatic system using Particle Swarm Optimization," *Simul. Model. Pract. Theory*, vol. 52, pp. 164-179, March 2015.

- [33] S. N. S. Salim, et al., "Position control of pneumatic actuator using self-regulation nonlinear PID," *Math. Probl. Eng.*, vol. 2014, pp. 1-12, June 2014.
- [34] S. N. S. Salim, et al., "A Study on Tracking Performance of the Pneumatic System with Enhanced NPID Controller," *2015 10th Asian Control Conference (ASCC)*, pp. 1-6, 2015.
- [35] B. Yao, et al., "Empirical modeling and position control of single pneumatic artificial muscle," *Control Eng. Appl. Informatics*, vol. 18, no. 2, pp. 86-94, 2016.
- [36] N. N. Son, et al., "A novel adaptive feed-forward-PID controller of a SCARA parallel robot using pneumatic artificial muscle actuator based on neural network and modified differential evolution algorithm," *Rob. Auton. Syst.*, vol. 96, pp. 65-80, October 2017.
- [37] G. Yang, et al., "Asymmetric Fuzzy Control of a Positive and Negative Pneumatic Pressure Servo System," *Chinese J. Mech. Eng.*, vol. 30, no. 6, pp. 1438-1446, 2017.
- [38] N. Kanagaraj and K. S. Nisar, "Fuzzy Fractional-Order PID Controller for Fractional Model of Pneumatic Pressure System," *Mathematical Problems in Engineering*, vol. 2018, pp.1-9, 2018.
- [39] C. D. E. Investigaci, "Design of a tracking controller of a siso system of pneumatic servopositioning [in Spanish: Diseño de un controlador de seguimiento para un sistema siso de servoposicionamiento neumatico]," *Ingeniería y Desarrollo*, vol. 36, no.1, 2018.
- [40] J. Song and Y. Ishida, "A robust sliding mode control for pneumatic servo systems," *Int. J. Eng. Sci.*, vol. 35, no. 8, pp. 711-723, June 1997.
- [41] E. Richer and Y. Hurmuzlu, "A High-Performance Pneumatic Force Actuator System Part 2-Nonlinear Controller Design," *ASME J. Dyn. Syst. Meas. Control*, vol. 122, no.3, pp. 426-434, 2000.
- [42] S. R. Pandian, et al., "Pressure observer-controller design for pneumatic cylinder actuators," in *IEEE/ASME Trans. Mechatronics*, vol. 7, no. 4, pp. 490-499, Dec 2002.
- [43] E. J. Barth, et al., "Sliding mode approach to PWM-controlled pneumatic systems," *Proc. 2002 Am. Control Conf. (IEEE Cat. No.CH37301)*, vol. 3, pp. 2362-2367, Feb 2002.
- [44] G. M. Bone and S. Ning, "Experimental comparison of position tracking control algorithms for pneumatic cylinder actuators," *IEEE/ASME Trans. Mechatronics*, vol. 12, no. 5, pp. 557-561, Oct 2007.
- [45] Y. C. Tsai and A. C. Huang, "Multiple-surface sliding controller design for pneumatic servo systems," *Mechatronics*, vol. 18, no. 9, pp. 506-512, 2008.
- [46] D. H. Yuan, et al., "Global sliding mode variable structure control applied to pneumatic servo system," *2008 IEEE International Symposium on Knowledge Acquisition and Modeling Workshop*, pp. 806-809, 2008.
- [47] H. Zhao, et al., "Two-layer Sliding Mode Control of Pneumatic Position Synchro System with Feedback Linearization Based on Friction Compensation," *2008 Int. Work. Rob. Sensors Environments*, pp. 41-45, 2008.
- [48] C. H. Chen, et al., "Design and Realization of a Sliding Mode Control Scheme for a Pneumatic Cylinder X-Y Axles Position Servo System," *IET Int. Conf. Front. Comput. Theory, Technol. and Appl.*, Taichung, 2010, pp. 416-421.
- [49] S. Hodgson, et al., "Sliding-mode control of nonlinear discrete-input pneumatic actuators," *2011 IEEE/RSJ International Conference on Intelligent Robots and Systems*, pp. 738-743, 2011.
- [50] A. Estrada and F. Plestan, "Second order sliding mode output feedback control with switching gains Application to the control of a pneumatic actuator," *J. Franklin Inst.*, vol. 351, no. 4, pp. 2335-2355, 2014.
- [51] A. Rezoug, et al., "Experimental Study of Nonsingular Terminal Sliding Mode Controller for Robot Arm Actuated by Pneumatic Artificial Muscles," *IFAC Proceedings Volumes*, vol. 47, no. 3, pp. 10113-10118, 2014.
- [52] A. Ayadi, et al., "Chattering-free adaptive sliding mode control for pneumatic system position tracking," *16th Int. Conf. Sci. Tech. Autom. Control Comput. Eng. STA 2015*, pp. 752-757, 2015.
- [53] M. C. Hidalgo and C. Garcia, "Friction compensation in control valves: Nonlinear control and usual approaches," *Control Eng. Pract.*, vol. 58, pp. 42-53, January 2017.
- [54] M. Krstic, et al., "Nonlinear and adaptive control design", John Wiley and Sons, 1995.
- [55] J. J. Slotine and W. Li, "Applied Nonlinear Control," Prentice-Hall, Inc., 1991.
- [56] X. Gao and Z. J. Feng, "Design study of an adaptive Fuzzy-PD controller for pneumatic servo system," *Control Eng. Pract.*, vol. 13, no. 1, pp. 55-65, January 2005.
- [57] Y. Zhu and E. J. Barth, "Accurate sub-millimeter servo-pneumatic tracking using model reference adaptive control (MRAC) 1 Introduction," *International Journal of Fluid Power*, vol. 11, no. 2, pp. 43-55, 2010.
- [58] Y. Shtessel, et al., "Lyapunov design of adaptive super-twisting controller applied to a pneumatic actuator," *IFAC Proceedings Volumes*, vol. 44, no. 1, pp. 3051-3056, 2011.
- [59] M. Farag and N. Z. Azlan, "Adaptive Backstepping Position Control of Pneumatic Anthropomorphic Robotic Hand," *Procedia Comput. Sci.*, vol. 76, pp. 161-167, 2015.
- [60] S. Y. Chen and S. S. Gong, "Speed tracking control of pneumatic motor servo systems using observation-based adaptive dynamic sliding-mode control," *Mech. Syst. Signal Process.*, vol. 94, pp. 111-128, Sep 2017.