

# Optimization of Energy Consumption in KUKA KR 16 Articulated Robot Manipulator

Hairol Nizam Mohd Shah, Marizan Sulaiman, Kamarul Syaffiq Mohamad Isa, Zalina Kamis, Mohd Rizuan Baharon

**Abstract:** A study for optimal energy consumption in KUKA KR 16 articulated robot for pick-and-place task is introduced in this paper. In order to achieve the optimal energy consumption, an improved trajectory planning is required. Essentially, trajectory planning encompasses path planning in addition to planning how to move based on velocity, time and kinematics. Trajectory planning gives a path from a starting to a goal point by avoiding collisions in a 2D or 3D space. Therefore, this paper focuses on analyzing the PTP motion and Linear motion in order to determine which is the best motion that can improve the trajectory planning. The optimal energy consumption to minimize the movement based on three main axes where it used a big motor used to drive the axes. This method is much simpler in terms of development process and did not require any additional hardware to be installed to the robot's system. KUKA KR 16 is used to study optimal energy consumption and analyze PTP and Linear motion. The energy performance is measured with respect to two categories of movements known as Default and Optimal movement which do the same task repetitively within specific time. The results show that PTP motion consumed 6% more energy than Linear motion but completed 773 cycles within one hour whereas Linear motion only completed 492 cycles. Energy performance between Default and Optimal movement shows that Optimal movement recorded 21.8% less energy usage when compared to Default movement although the total cycles completed for both movements are almost the same.

**Index Terms:** Optimal energy, KUKA KR 16, Energy consumption, Joints movement.

## I. INTRODUCTION

Industrial robots are often perceived as unsustainable machinery requiring a high energy consumption level. These robots, however, provide accuracy, strength and sensing capacities that can generate end products of high quality. Consequently, for many study organizations and robot producers, robotic energy consumption became a significant goal. Consequently, for many study organizations and robot

producers, robotic power consumption became a significant goal. Several scientists concentrated on defining instruments for measuring and analyzing the energy consumption of the robot.

For example the work reported by Chemnitz [1] contributes to identifying energy efficient strategies in robotic applications. Others [2] summarized various techniques of using prevalent industrial robots energy-efficiently. At the same moment, many scientists submitted robotic solutions to trajectory planning that are capable of optimizing time and energy consumption [3].

These methods, however, place a high priority on minimizing a robot's motion time, which may not necessarily result in energy consumption being minimized. The complete energy consumed by the robot on each joint and operating velocity of the robot is generally influenced by the necessary angle rotation. Other scientists concentrated on optimizing the entire robotic production system [4].

Despite the above attempts, it continues a challenge to minimize robotic energy consumption and needs further research. In the context of industrial robots, energy consumption can be enhanced by optimizing the working timetable of industrial robots and by selecting industrial robots with low energy consumption levels or by optimizing the operating parameters of industrial robots and their apertures.

Different trajectories imply varying degree of freedom (DOF) participation, which in turn implies distinct engines working. The most typical industrial robot has 6 degrees of liberty from which 1 to 3 axis is used for center point place of the instrument (TCP) and orientation axis 4 to 6. Normally, 1 to 3 axis used bigger engines than 4 to 6 axis. Reducing the use of these big engines throughout the entire working phase can lead to the optimization of one of the operating parameters of the industrial robot.

## II. RELATED WORKS

Banga et al. [5] used Fuzzy Logic (FL) and Genetic Algorithms (GA) to provide ideal movement control and trajectory planning for four-degree robots. This study assessed four degree-of-free robotics arm using Fuzzy Logic and Genetic Algorithms. By using Fuzzy Logic and Genetic Algorithms, uncertainties such as motion, friction and settling time in robotic arm motion have been compensated. Only Genetic Algorithm and Fuzzy Genetic Algorithm compare the outcomes. Furthermore, a new technique for time-optimal motion planning based on enhanced Genetic Algorithm has been suggested, incorporating the robotic manipulator's kinematics limitations,



Revised Manuscript Received on September 23, 2019

**H.N.M. Shah**, Center of Excellence for Robotics and Industrial Automation Laboratory, Fakulti Kejuruteraan Elektrik, Universiti Teknikal Malaysia Melaka (UTeM), Malaysia.

**M. Sulaiman**, Center of Excellence for Robotics and Industrial Automation Laboratory, Fakulti Kejuruteraan Elektrik, Universiti Teknikal Malaysia Melaka (UTeM), Malaysia

**K.S.M. Isa**, Center of Excellence for Robotics and Industrial Automation Laboratory, Fakulti Kejuruteraan Elektrik, Universiti Teknikal Malaysia Melaka (UTeM), Malaysia

**Z. Kamis**, Center of Excellence for Robotics and Industrial Automation Laboratory, Fakulti Kejuruteraan Elektrik, Universiti Teknikal Malaysia Melaka (UTeM), Malaysia

**M. R. Baharon**, Department of Computer System and Communication, Faculty of Communication and Information Technology, Universiti Teknikal Malaysia Melaka (UTeM), Malaysia

dynamic limitations and control constraints [6].

One of the main study problems in the field of robotics is the construction of independent, smart robots that can plan a collision-free route. Banga et. Al.[5] outlined a mixed Fuzzy Logic and Genetic Algorithm to fix the four-degree robotic path planning. A fuzzy logic controller is used in the suggested technique to locally discover barrier-free instructions, and Genetic Algorithm is used as optimizers to locate ideal places along the barrier-free paths. A novel algorithm for ideal trajectory planning with barriers for a 2-DOF manipulator is provided using Disjunctive Programming [7].

In the case of multi-arm manipulators, Rana and Zalzal [8] outlined a technique for designing a near-time, collision-free movement. In the joint room, trajectory planning is performed and the route is represented by knots linked through cubic splines. A technique was defined and implemented to mobile robot movement planning to model the movement uncertainty of moving obstacles [9]. This technique took into account three sources of movement uncertainty: ambiguity of route, uncertainty of velocity and uncertainty of observation. They represented the model by a probabilistic distribution over possible position on the path of a moving obstacle.

Using this model, the best robot movement was chosen, minimizing the anticipated time to reach the target due to the uncertainty distribution. Jamisola et. al. [10] provided a technique of searching for a constant obstacle-free room between the starting setup and the required end-effector position defined by a target self-motion manifold in the joint room. This method guarantees completion of critical task in the event of a single locked-joint failure in the presence of obstacles.

McAvoy et. al. [11] suggested a Genetic Algorithms strategy for ideal point-to-point movement planning for cinematic redundant manipulators to meet both the initial conditions and certain other defined requirements. Their strategy combines B spline curves with Genetic Algorithms for ideal solution to generate smooth trajectories. Tian and Collins [12] suggested a Genetic Algorithm using a floating point representation to search for a redundant manipulator's ideal end-effector trajectory. An evaluation function was implemented based on various criteria such as complete displacement of all joints and uniformity of Cartesian and joint space speeds. Simulations are performed in free space and in a workspace with barriers to check their strategy.

Kazem et. al.[13] suggested a genetic algorithm designed to optimize point-to-point trajectory scheduling for a redundant 3-link robot arm. The objective function for the proposed Genetic Algorithm was to minimize the traveling time and space, while not exceeding a maximum pre-defined torque, without collision with any obstacle in the robot workspace. Quadrinomial and quintic polynomials have been used to define the sections at the joint-space that connect original, intermediate and final point. Direct cinematics was used to avoid the robot arm's unique settings.

Also used was the genetic algorithm to optimize point-to-point trajectory scheduling for a robotic arm with 3 links[14]. The objective function of the suggested Genetic Algorithm is to minimize the energy consumed in robotic arm and travel time by the actuators, while not exceeding a maximum pre-defined torque, without collision with any barrier in the robot workspace. The fourth and fifth-order

polynomials are used to define the sections that connect original, intermediate, and final points at the joint-space.

Energy consumption is basically the complete energy that human civilization uses to cater for the socio-economic-political sphere and the industrial sector of humanity. As a consequence, increased general power consumption became one of the main contributions. In this industry, robotics and automation are commonly used. They are used to substitute human employees without neglecting the quality in order to improve productivity. Unfortunately, these robots have to work at high speed and accuracy to fulfill the output production. This will lead to higher energy consumption. On the contrary to expectations it turns out that slow motions are not necessarily the most energy efficient [15-19].

### III. RESEARCH METHODOLOGY

The articulated-arm robot with six degrees of liberty (DOF) KUKA KR 16 was used to create and show an strategy in the real-world experiments. For these robots, the forward and reverse architecture of kinematics must first be identified. To achieve the manipulator's forward kinematic equations, a connection is only regarded as a rigid body that describes a manipulator's connection between two common axes. Joint axes are described in space by lines. Hence, for kinematic purpose, a link can be specified with two numbers which define the relative location of the two axes in space.

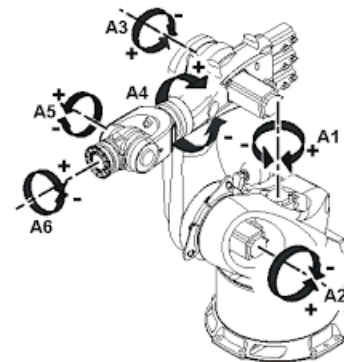

**Figure 1: The coordinate frames of KUKA KR 16**

Referring to Figure 1, at joint 1,  $z_0$  is representing the first joint going upwards as it is a revolute joint. Then the direction of  $x_0$  is chosen to be parallel with the reference frame of x-axis. Next  $z_1$  is assigned at joint 2 and since  $z_0$  and  $z_1$  are intersecting,  $x_1$  will be assigned as common normal. At joint 3,  $z_2$  will have same direction as  $z_1$  and  $x_2$  will be common normal between  $z_1$  and  $z_2$ . Direction of  $z_3$  and  $z_5$  is the same because both representing the same frame. So the direction of  $x_3$ ,  $x_4$  and  $x_5$  is the same because in the direction of the common normal between  $z_2$ ,  $z_3$ ,  $z_4$  and  $z_5$ .  $z_4$  represent the motions of joint 5 and  $z_6$  represent the motions of the end effectors.

The most popular technique for describing robot kinematics is the Denavit-Hartenberg technique using four parameters. When assigning the coordinate frames, the standard 4x4 homogeneous transformation matrix can be used to represent the transformation between adjacent coordinate frames (Verma et al. 2010). Frame[i-1] and frame[i] should be consider in order to find the transformation matrix relating two frames attached to the adjacent links. The transformations of frame[i-1] to frame[i] consists of four basic transformations.

- i. A rotation about  $z_{i-1}$  axis by an angle  $\theta_i$  ;
- ii. Translations along  $z_{i-1}$  axis by distance  $d_i$  ;
- iii. Translation by distance  $a_i$  along  $x_i$  axis and
- iv. Rotation by an angle  $\alpha_i$  about  $x_i$  axis

Every joint has a position and orientation relative to its previous joint. These relations are described by transformation matrices. A general formulation for calculation of these matrices is show in Eq. 1.

$${}^{i-1}T_i = R_x(\alpha_{i-1})D_x(a_{i-1})R_z(\theta_i)D_z(d_i) \quad (1)$$

The KUKA KR 16 is a six-axis degree of freedom (D.O.F) manipulator with nonzero offset (denoted by the nonzero link length ( $a_i, i = 0,1,\dots,6$ ) at each of the joints. This robot has its own limitation on its workspace as shown in Figure 2. It is more efficient to numerically compute the forward kinematics function  ${}^0T_6$  via a link-by-link iteration of the form as show in Eq. 2.

$${}^0T_6 = {}^0T_1 {}^1T_2 {}^2T_3, \quad i = 0,1,\dots,6 \quad (2)$$

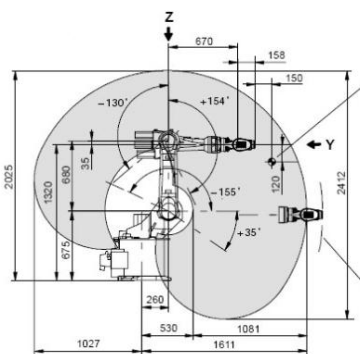

Figure 2: KUKA KR 16 dimension

By using Eq. 2, we considering the initial position where the value for all  $\theta = 0$ . The forward kinematics equation of the robot can derived as Eq. 3 and 4.

$${}^0T_6 = {}^0T_1 {}^1T_2 {}^2T_3 {}^3T_4 {}^4T_5 {}^5T_6, \quad i = 0,1,\dots,6 \quad (3)$$

$${}^0T_6 = \begin{bmatrix} 1 & 0 & 0 & 435 \\ 0 & -1 & 0 & 0 \\ 0 & 0 & -1 & 710 \\ 0 & 0 & 0 & 1 \end{bmatrix} \quad (4)$$

The KUKA KR 16 arm robot has six-axis degree of freedom (D.O.F) with nonzero offset also denoted by the nonzero link length  $a_i$ , at each of the joints. The forward kinematics equation of the robot can derived as Eq. 5.

$${}^0T_6 = \begin{bmatrix} 1 & 0 & 0 & 975 \\ 0 & -1 & 0 & 0 \\ 0 & 0 & -1 & 1460 \\ 0 & 0 & 0 & 1 \end{bmatrix} \quad (5)$$

As forward kinematics utilizes the joint parameters to calculate the manipulator setup, this calculation is reversed by reverse kinematics to determine the joint parameters that achieve a required setup. Inverse cinematics relates to the use of a robot's cinematic equations to determine the joint parameters which provide the required end-effector position.

### A. KUKA KR 16

An optimization motion for the KUKA KR 16 robot is created on the basis of previous experimental outcomes. The tests are split into two motion classifications: Default movement and Optimal motion. Details are discussed individually in the sub chapter for both movements. The aim of this experiment is to compare the energy consumption and task finished between these movements within a particular moment, thus verifying the efficacy of this technique. This experiment's pick-and-place assignment varies from the KUKA KR 16 experiment. Although for one full cycle it still uses eight steps, but the atmosphere is distinct. Figure 3 shows the pick-and-place job performed from the top perspective for both movements.

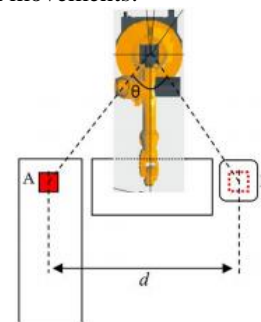

Figure 3: Pick-and-place task illustration for KUKA KR 16 from top view

### B. Energy Measurement

Using Fluke 435 Power Quality Analyzer, the energy for the general assignment was evaluated in the KUKA KR 16 robot. The pick-and-place robot motions used all of its joint engine including the controller energy that was connected with the robot. Hence, the measurement was done for energy consumption of the robot and the controller.

The energy was evaluated at the single-phase supply input cable and three-phase supply. Figure 4 and Figure 5 illustrate how the analyzer meter connects to the supply. The energy will be tracked by the analyzer meter once the robot starts moving from home until the job is complete.

It will generate actual power (kWh) measurement. Upon completion of the assignment, the energy reading is stopped by executing the stop command on the analyzer meter panel. The investigator records the measurement values manually for each phase of the movements and experiments.

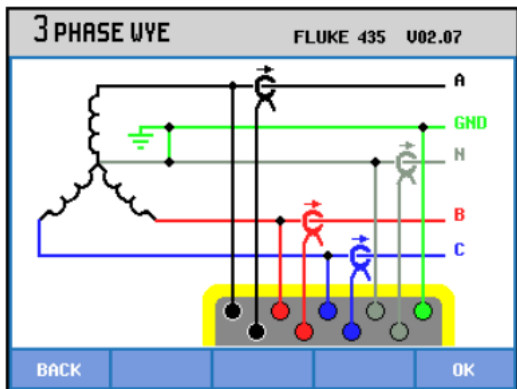

Figure 4: Connection of Fluke 435 to 3-phase system



Figure 5: Fluke 435 Connected to KUKA KR 16 control unit

#### IV. RESULTS

##### A. Experimental Setup

The real-time application experimental is designed to assist the outcomes of the simulation with experimental outcomes. In this studies, the experimental verification for the optimal energy usage motion has been achieved. The run time is set at 5 minutes, 15 minutes, 30 minutes and 1 hour.

The experiments were performed 3 times for both Default and Optimal movements to decrease the random error in the 74 measurement method. The average test results values were taken as the robot's real energy consumption. Figure 6 to Figure 8 shows the pick-and-place assignment experiment set-up.



Figure 6: KUKA KR 16 Pick Object Position



Figure 7: KUKA KR 16 Place Object Position



Figure 8: KUKA KR 16 Experiment Setup

##### B. Simulation Results

Using RoboAnalyzer software, the simulation findings for KUKA KR 16 shown in Figure 9 and Figure 10 were acquired. The findings indicate the Joint Value, Joint Velocity acquired through the differentiation of the information of the Joint Position and Joint Acceleration acquired by the subsequent differentiation of the information of the velocity.

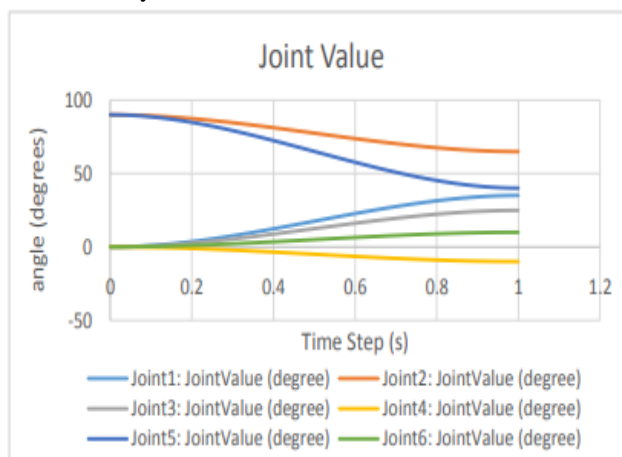

(a) Joint Value

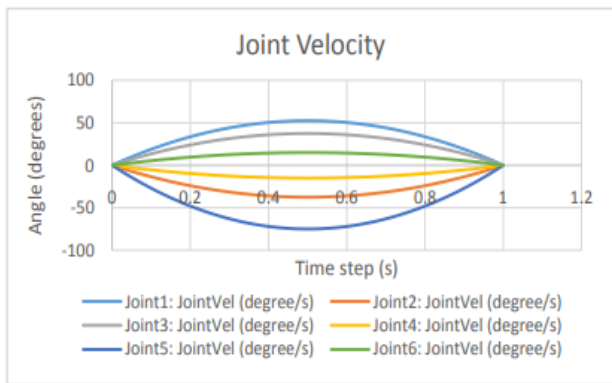

(b) Joint Velocity

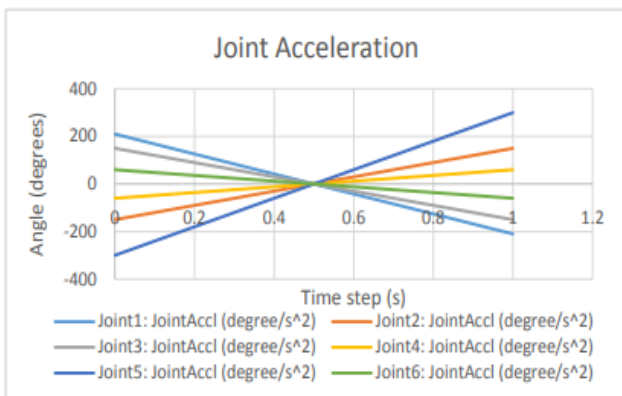

(c) Joint Acceleration

Figure 9: Graph for Pick Cube Movement for KUKA KR 16

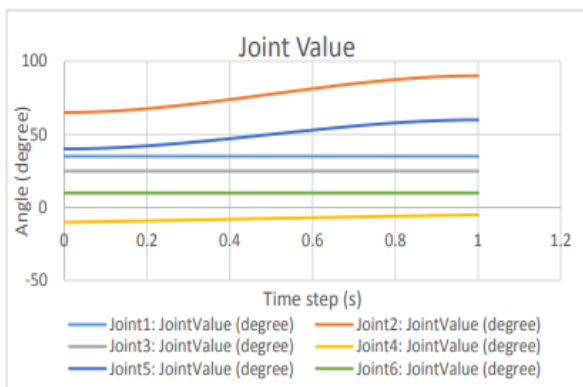

(a) Joint Value

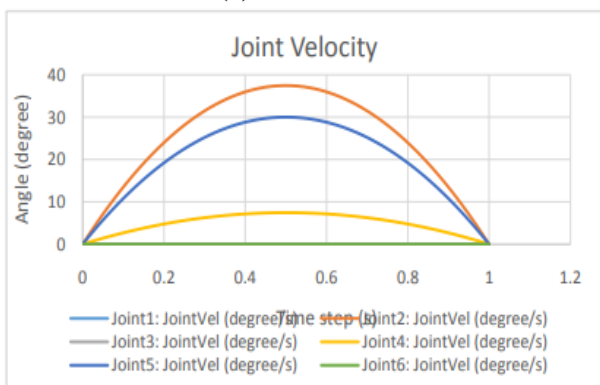

(b) Joint Velocity

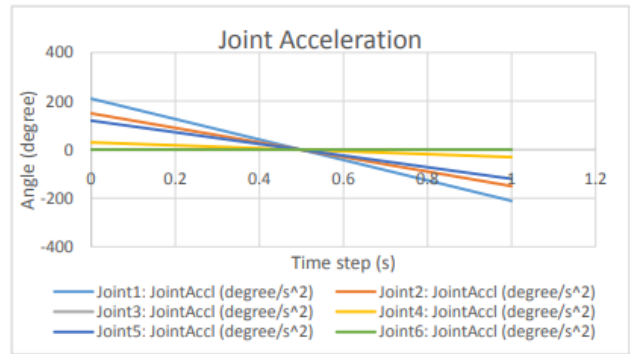

(c) Joint Acceleration

Figure 10: Graph for Return to Position 1 Movement for KUKA KR 16

### C. KUKA KR 16 Results

The results for comparison of measured energy usage for one complete cycle and energy measurement within specific time frame for KUKA KR 16.

#### Comparison of Measured Energy Usage for one (1) Complete Cycle

The experiment was done to determine one (1) complete cycle time performance of pick-and-place task for Default and Optimal movement using KUKA KR 16 robot. During the experiment, the energy consumption was measured and recorded using a Fluke 435 power quality analyzer. The time taken for one (1) complete cycle also was recorded.

In Default movement, for 10% of operating speed energy usage recorded 0.0089 kWh and the time taken to complete one task was 26.09s. At 30% of 0 0.05 0.1 0.15 0.2 0.25 0.3 0.35 0.4 0.45 0.5 min 15 min 30 min 1 hour Energy measure (kWh) Time Linear motion Energy Measurement 3% 10% 30% 50% 98 operating speed, the energy usage was 0.0041 kWh and completed a task in 10.26s. For 50% of operating speed, the time recorded was 6.94s and energy measured was 0.0036 kWh. As for 75% of operating speed, the energy usage was 0.0031 kWh and took 5.07s to complete a task. Lastly, at 100% of operating speed, energy usage recorded was 0.0029 kWh and time taken to complete one (1) task was 3.89s.

Meanwhile, for Optimal movement, at 10% of operating speed recorded 0.0081 kWh and took 24.65s to complete a task. For 30% of operating speed, the energy usage was 0.0037 kWh and took 9.42s to complete one (1) cycle. At 50% of operating speed, the time recorded was 6.31s and energy measured was 0.0028 kWh. For 75% of operating speed, one (1) cycle energy usage was 0.0023 and took 4.59s to complete one (1) cycle. Lastly, at 100% of operating speed, energy usage was 0.0019 kWh and complete one (1) cycle at 3.25s. Figure 11 shows graph for comparison of energy consumption between Default and Optimal movement for 1 complete cycle.

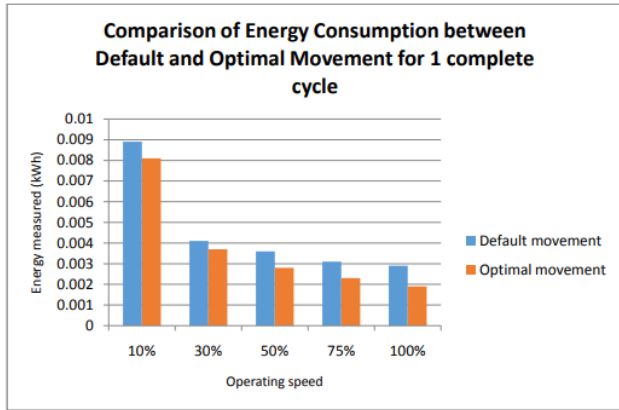

Figure 11: Graph for Comparison of Energy Consumption between Default and Optimal Movement for 1 complete cycle

Energy Measurement within Specific Time Frame

These experiments are to determine the energy performance of pick-and-place task for Default movement and Optimal movement using KUKA KR 16 robot. Five experiments were conducted for each type of movement within one hour session. During the experiments, the electrical energy being used was measured and recorded using a Fluke 435 power quality analyzer meter. The 0 0.001 0.002 0.003 0.004 0.005 0.006 0.007 0.008 0.009 0.01 10% 30% 50% 75% 100% Energy measured (kWh) Operating speed Comparison of Energy Consumption between Default and Optimal Movement for 1 complete cycle Default movement Optimal movement 100 number of cycle completed for each repetitive pick-and-place task also was recorded.

After one hour of repetitive task, energy measured for Default movement are 1.175 kWh at 10% of operating speed, 1.425 kWh at 30% of operating speed, 1.829 kWh at 50% of operating speed, 2.213 kWh at 75% of operating speed and 2.693 kWh at 100% of operating speed. The total cycles completed within one hour were 144 cycles for 10% of operating speed, 379 cycles for 30% of operating speed, 585 cycles for 50% of operating speed, 781 cycles for 75% of operating speed and 1055 cycles for 100% of operating speed. Figure 12 shows graph for Default movement energy measurement.

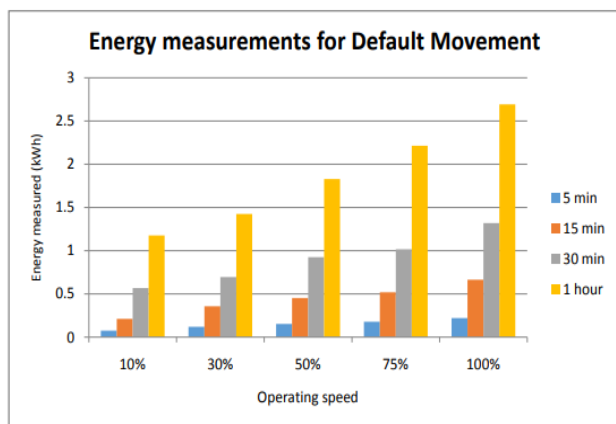

Figure 12: Graph for Default Movement Energy Measurement

Whereas energy measurement within one hour for Optimal Movement recorded 1.140 kWh for 10% of operating speed, 1.417 kWh for 30% of operating speed, 1.598 kWh for 50% of operating speed 1.817 kWh for 75% of operating speed

and 2.106 kWh for 100% of operating speed. The total cycles completed within one hour were 146 cycles for 10% of operating speed, 382 cycles for 30% of operating speed, 587 cycles for 50% of operating speed, 784 cycles for 75% of operating speed and 1058 cycles for 100% of operating speed. Figure 13 shows graph for Optimal movement energy measurement.

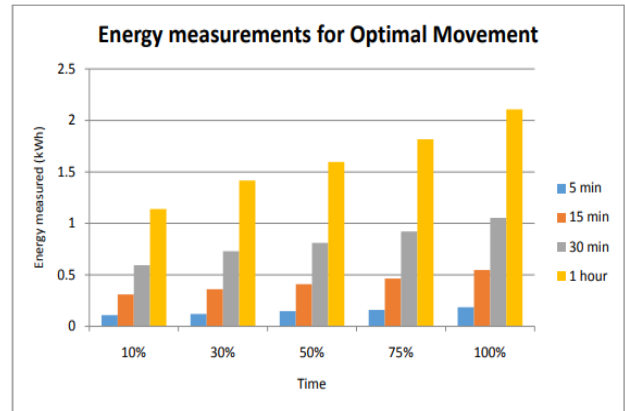

Figure 13: Graph for Optimal Movement Energy Measurement

V. CONCLUSION

This paper describes that the dynamic performance of the arm manipulator’s task can be optimized without using special tools. The pick-and-place task can be done automatically by the manipulator itself. It was a pre-defined motion. Thus it needs to move with the movement that can provide the minimal energy usage and least motion time. The experiments results shows that the movement with less cycle time and with the fastest operating speed is more efficient in their overall dynamic performance. In the energy measurements, it is obvious that the Default movement used about 21.8% more energy compared to Optimal movement. Surprisingly, the slow motions need much more energy than the fast ones for one (1) complete cycle.

In order to further investigation the effectiveness of this paper output, another type of task can be implemented using this system and its applicability can be then re-appraised. It is suggested that to conduct a task which similar and are used widely in the industry so that the result from the research can directly be implement to the real industrial environment. Other future work involves an experimental campaign to assess the precision and effectiveness of the technique on multi-robot cells, the creation of internet programming algorithms and the application of specialized simulation tools to be incorporated into proprietary software. Moreover, using distinct payloads, the same task and method can be used from this studies to determine energy consumption.

ACKNOWLEDGMENT

The authors are grateful for the support granted by by Center for Robotics and Industrial Automation, Universiti Teknikal Malaysia Melaka (UTeM) in conducting this research through grant JURNAL/2018/FKE/Q00007 and Ministry of Higher Education.



## REFERENCES

1. Chemnitz, M., Schreck and G., Kruger, J. Analyzing Energy Consumption of Industrial Robots. In: 16th IEEE Conference on Emerging Technologies and Factory Automation (ETFA), Toulouse, France, 5-9, pp. 1-4, 2011.
2. Meike, D. and Ribickis, L. Analysis of the Energy Efficient Usage Methods of Medium and High Payload Industrial Robots in the Automobile Industry. In: 10th International Symposium "Topical Problems in the Field of Electrical and Power Engineering" 2011, Parnu, Estonia, 10-15, pp. 62-66, 2011.
3. Hansen, C., Oltjen, J., Meike, D. and Ortmaier, T., 2012. Enhanced Approach for Energy Efficient Trajectory Generation of Industrial Robot. In: 8th IEEE International Conference on Automation Science and Engineering, Seoul, Korea, 20-24 August 2012, pp. 1-7.
4. Vergnano, A., Thorstensson, C., Lennartson, B., Falkman, P., Pellicciari, M., Leali, F. and Biller, S. Modeling and Optimization of Energy Consumption in Cooperative MultiRobot Systems. IEEE Transactions on Automation Science and Engineering, 9(2), pp. 423-428, 2012.
5. Banga, V. K., Kumar, R. and Singh, Y. Fuzzy-Genetic Optimal Control for Four Degree of Freedom Robotic Arm Movement. International Journal of Mechanical, Aerospace, Industrial, Mechatronic and Manufacturing Engineering, 3(12), pp. 1537-1540, 2009.
6. Sharma, G. S. and Kaur, A. Optimization of Energy in Robotic Arm Using Genetic Algorithm. International Journal of Computer Science and Technology (IJCSST), 2(2), pp. 315-317, 2011.
7. Anjana, K., Sudheer, A. P. and Mija, S. J. Optimal Trajectory Planning and Control of 2 DOF Robotic Manipulator. Asian Journal of Engineering and Technology (Special Issue for ICETTAS '15), 3(4), pp. 363-367, 2015.
8. Rana, A. S. and Zalzal, A. M. S. Near Time-Optimal Collision-Free Motion Planning of Robotic Manipulators Using an Evolutionary Algorithm. Journal of Robotica, 14 (6), pp. 621-632, 1996.
9. Miura, J. and Shirai, Y. Modeling Motion Uncertainty of Moving obstacles for Robot Motion Planning. In: Proceedings of IEEE International Conference on Robotics & Automation, 24 – 28 April 2000, pp. 2258-2263, 2000.
10. Jamisola, R. S., Maciejewski, A. A. and Roberts, R. G. A Path Planning Strategy for Kinematically Redundant Manipulators Anticipating Joint Failures in the Presence of Obstacles. In: Proceedings of IEEE/RSJ International Conference on Intelligent Robots and Systems, 27–31 October 2003, pp. 142-148, 2003.
11. McAvoy, B., Sangolola, B. & Szabad, Z. Optimal Trajectory Generation for Redundant Planar Manipulator. In: Proceedings of the IEEE International Conference on Systems, Man, and Cybernetics, Nashville, pp. 3241-3246, 2000.
12. Tian, L. and Collins, C. Motion Planning for Redundant Manipulators using a Floating Point Genetic Algorithm. Journal of Intelligent and Robotic Systems: Theory and Applications, 38 (3-4), pp. 297-312, 2003.
13. Kazem, B. I., Mahdi, A. I. and Oudah, A. T. Motion Planning for a Robot Arm by Using Genetic Algorithm. Jordan Journal of Mechanical and Industrial Engineering (IJMIE), 2(3), pp. 131-136, 2008.
14. Gouri, S. S. and Amanpreet, K. Optimization of Energy in Robotic arm using Genetic Algorithm. International Journal of Computer Science and Technology, 2 (2), pp. 315-317, 2011.
15. EA Alandoli, M Sulaiman, MZA Rashid, HNM Shah, Z Ismail, "A review study on flexible link manipulators", Journal of Telecommunication, Electronic and Computer Engineering (JTEC), 8(2), pp. 93-97, 2016.
16. M Kazim, MN Fakhzan, M Shah, H Nizam, MD bin Muhammad Nasir. "Theoretical Analysis on Energy Consumption For Industrial Robots", Applied Mechanics and Materials, 699, pp. 846-852, 2015.
17. EA Alandoli, HNM Shah, M Sulaiman, MZA Rashid, MSM Aras, "PD/H-∞ Integrated Controller for Position Tracking and Vibration Suppression of Flexible Link Manipulator System", International Journal of Mechanical & Mechatronics Engineering, 18(3), pp. 54-61, 2018.
18. HNM Shah, M Sulaiman, AZ Shukor, Z Kamis, "An experiment of detection and localization in tooth saw shape for butt joint using KUKA welding robot", The International Journal of Advanced Manufacturing Technology, 97 (5-8), pp. 3153-3162, 2018.
19. HNM Shah, M Sulaiman, AZ Shukor, MZ Ab Rashid, "Recognition of butt welding joints using background subtraction seam path approach

for welding robot", International Journal of Mechanical & Mechatronics Engineering, 17 (01), 57-62, 2017.