

## Automatic Sliding Gate System using Tap Water Pressure

M. B. Ali

Fakulti Teknologi Kejuruteraan Mekanikal dan Pembuatan, Universiti Teknikal Malaysia Melaka

K. A. Zakaria

Fakulti Kejuruteraan Mekanikal, Universiti Teknikal Malaysia Melaka

Sivakumar, D.

Fakulti Kejuruteraan Mekanikal, Universiti Teknikal Malaysia Melaka

Hadzley, AB

Fakulti Teknologi Kejuruteraan Mekanikal dan Pembuatan, Universiti Teknikal Malaysia Melaka

他

<https://doi.org/10.5109/4480722>

---

出版情報 : Evergreen. 8 (2), pp.408-413, 2021-06. Transdisciplinary Research and Education Center for Green Technologies, Kyushu University

バージョン :

権利関係 :



# Automatic Sliding Gate System using Tap Water Pressure

M. B. Ali<sup>1,3,\*</sup>, K. A. Zakaria<sup>2,3</sup>, D. Sivakumar<sup>2,3</sup>, AB Hadzley<sup>1</sup>, Norfauzi Tamin<sup>1</sup>, Kevin Tan<sup>2</sup>, Faiz Aswad<sup>2</sup>

<sup>1)</sup> Fakulti Teknologi Kejuruteraan Mekanikal dan Pembuatan, Universiti Teknikal Malaysia Melaka, Hang Tuah Jaya, 76100 Durian Tunggal, Melaka, Malaysia

<sup>2)</sup> Fakulti Kejuruteraan Mekanikal, Universiti Teknikal Malaysia Melaka, Hang Tuah Jaya, 76100 Durian Tunggal, Melaka, Malaysia

<sup>3)</sup> Centre for Advanced Research on Energy, Universiti Teknikal Malaysia Melaka, Hang Tuah Jaya, 76100 Durian Tunggal, Melaka, Malaysia

E-mail: basri@utem.edu.my

(Received January 7, 2021; Revised April 26, 2021; accepted April 26, 2021).

**Abstract:** Current automatic gates control utilizes electrically powered motor, which is relatively expensive in term of installation, operation, and maintenance that increases the cost of automatic gates. For this, a new idea with automatic gate control system that uses a source directly from tap water pressure to operate the movement of gate that is controlled with fluid power valves and cylinders is developed. Tap water is directly connected to the system and does not use any additional pump to increase the pressure. A double acting cylinder, solenoid valves and a remote-control switch are the main components in this product. The type of gate that are consider for this paper are swing gate and sliding gate. For sliding gate type, an additional device that is able to extend the maximum reach of the piston cylinder is required. It is because the length of the piston cylinder is not long enough to open the gate. After choosing the best design from some design, the selected design was further analysed and simulated using Computer Aided Design (CAD) software. Then the CAD software could determine the motion by simulation what the distance is through which the gate can move or travel. The comparison between simulation data and actual data had a percentage of error of 24.68% which refers to the movement or distance of gate travelled. Finally, both type of gate refers to swing gate and sliding gate able to work using directly tap water. In conclusion the newly developed automatic gate control for each type is cheaper in term of initial and operating cost.

Keywords: Automatic gate, sliding gate, swing gate

## 1. Introduction

A fence or gate is a structure that is used to divide certain places that have different purposes or to prevent something uninvited to enter their territory. There are various designs of fence that are available in the market since few decades ago. In the past, the main purpose of fence was used for security purpose where to keep enemy or wild animal away from their home or livestock. The best example of fence that was used for defencing purpose was the great wall of China. The invention of fence has been around the world since even before civilization exist and keep on evolving until today. According to an article wrote by Brett Crouse (2014), a barbed wire fence was first invented at DeKalb Country Fair in Illinois during year 1873.

A gate is considered as a type of fence where it provides a pathway at the fence to allow people to cross the fence without the need to turn a whole big round around fence

in order to move to the other side. According to the book written by Kiyoshi Toko <sup>1)</sup>, the idea of automatic door or gate had been introduced more than 2000 years ago by Heron of Alexandria in a temple in Egypt. The concept of the automatic system was using water vapour and pneumatically open and close the door. Currently there are plenty mechanism of gate that available in the market. Some of the mechanisms are only suitable for certain application and have their own working principle. Therefore, choosing which mechanism of gate is very important where it depend on the condition of the area that going to be installed. There are several mechanisms for gate such as sliding gate, swing gate, vertical lift gate, vertical pivot lift gate, and barrier arm gate <sup>2,3)</sup>.

Nowadays automatic sliding gate has a wide range of use. Sliding gate is a type of gate that implemented the sliding mechanism that slide on a rail. To slide smoothly, a device that reduces the friction between the contact of the gate and ground is needed. Example of the device is

wheel or roller. By using wheels or rollers, a gate can slide easily even though the gate is very heavy <sup>14-19)</sup>. Sliding gate can be divided into a few types that apply different type of mechanism. The advantage of using sliding gate is it is space saving during operation when compared to swing gate <sup>4)</sup>. The swing gate, on the other hand can be divided into two types which are single and double swing fence opening. This type of gate is common use for home because it is easy to install and the cost is less than other type of fence. The fence can open inwards or outwards <sup>5)</sup>. When the automatic system attaches to this type of fence, the fence usually can open in one direction only, either inwards or outwards.

The installation fee for the conventional automatic gate is high because the cost to purchase a motor is high as shown in Table 3 the comparison overall price. Therefore, a low-income household will have difficulty to acquire it. Besides that, even after the installation user still must spend some extra cost for the maintenance fee because only specialist technician can do the maintenance and the spare part for the automatic gate is costly too. Therefore, the cost for maintenance will be slightly higher <sup>2,3,6)</sup>. In additional most of the system that in the market do not provide a full efficiency system and those system have plenty of large, heavy, and complicated mechanism <sup>27)</sup>.

To solve this problem, this project with newly developed automatic gate control is cheaper in terms of initial and operating cost. Thus, the major contribution is to improve capability for the home automation <sup>7-11)</sup>, by considering the low cost of budget in selecting suitable infrastructure <sup>12, 13, 20)</sup>. To assure maximum cost benefit, appropriate component, maintenance, durability and operating condition are important parameters that need to be considered <sup>26)</sup>.

For this project, the double acting valve will be used to operate the swing gate and sliding gate. The valve will be moved by using water pressure supplied from the tap. The valve will be operated remotely by using an Arduino system.

## 2. Methodology

The flow chart in Fig. 1 shows the flow of this project. The first part is to require customer feedback related on the topic of the project. The feedback was required by using survey form. Then a quality function development (QFD) was used to develop a house of quality to translate customer requirement to engineering characteristic. By combining the voice of customer and QFD we can obtain customer satisfaction.

Afterward, a concept design was generated. It will be based on the customer requirement and engineering characteristics resulted from the QFD. From the concept design, few new concept designs were generated using morphology chart. Finally, the final concept design was selected by using Pugh method.

After choosing the concept for gate type, the simulation needs to be done before fabrication process. It is to

confirm that the system can run in good condition. This simulation had been tested using FluidSIM software platform. The result for simulation is successful and the entire component functioning as planned. For sliding gate, the simulation was done by using Computer Aided Design software <sup>21, 24, 25)</sup>. Kinematic simulation was done to simulate the movement of the design before fabrication <sup>22, 23, 24)</sup>. For this gate type the length of the piston cylinder is not long enough to fully open the gate. Therefore, an additional device that able to extend the maximum reach of the piston cylinder is required. After obtained the best design, the design was further analysis, and three more designs were generated from it.

The first design is three pairs of scissors with 500mm length of linkage, second design is four pairs of scissors with 500mm length of linkage and final design is four pairs of scissors with 700mm of linkage length. A general setup of the first design is shown in Fig. 5(a) where the device is connected to a sliding gate. The piston at the middle of the device will extend which allow the device to extend as well that result in the sliding movement of the gate which open and close the gate. After fabricating and test run the product for both type gate then the comparison with existing automatic gate using electrical power such as the cost and electric consumption were discussed thoroughly.

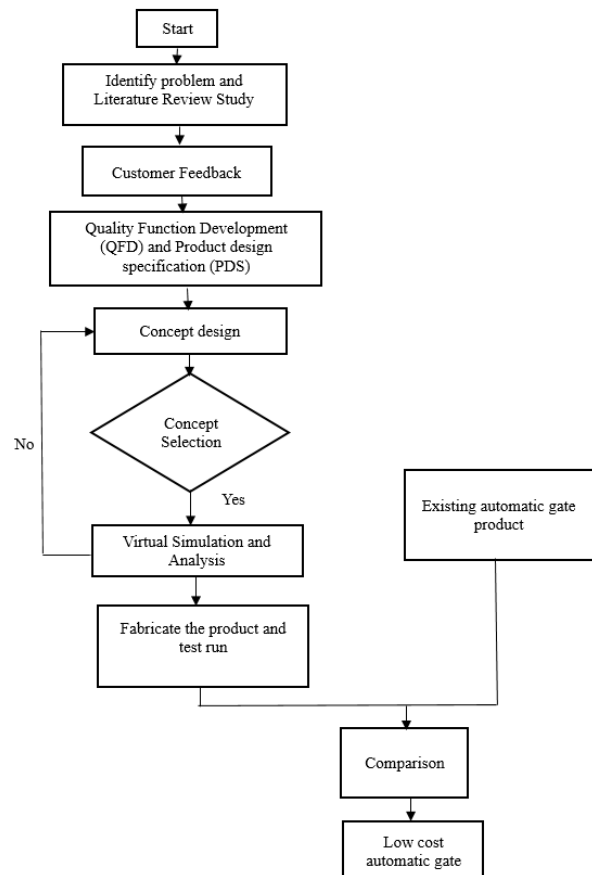

Fig. 1: Flow chart of this project

## Survey Analysis

According to the survey analysis, the most important characteristic for the product is low initial cost. The result show that customer tend to get attracted by product will lower price. The second more important is a product that easy to maintain or maintenance. This characteristic is also important because user do not require to hire expert to maintain the product because they able to maintain it themselves and at the same time can save maintenance cost. Moving on, third most important is the durability of the product. Every user would prefer product that has higher life span. Moreover, fourth most important characteristic is having other function other than opening and closing gate.

## House of Quality (HOQ)

The result for HOQ shows that material is the most important engineering characteristic during the development of the product because a good material will determine many characteristics of the product such as durability, cost, and strength. Second most important is weight because too heavy weight will increase the shipping cost and very difficult during installation and maintenance. Third most important is dimension of the product because large dimension will affect the cost, weight, and occupy large space. Forth rank for the ranking is speed because this characteristic will be used to determine time require to open and close gate. Finally, for fifth and sixth place are strength and force respectively.

## 3. Result and Discussion

### Pressure of the Tap Water Supply

The data of the pressure was obtained from previous report<sup>2)</sup> where he had done the research on the swing gate by using the same piston cylinder. The stability of the pressure of water throughout the day is important so that this project able to function as expected. The data of the pressure is shown in Fig. 2 below. According to the figure, the water pressure is at the lowest during the morning. For daily water pressure, it is on the average of 41 psi while the highest pressure is on Tuesday with 43 psi. Therefore, we can assume the total average of the pressure to be around 41.8 psi.

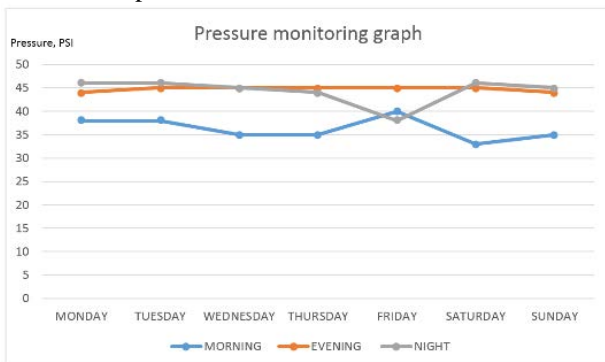

Fig. 2: Pressure of water throughout the day

### Simulation of selected concept for swing gate

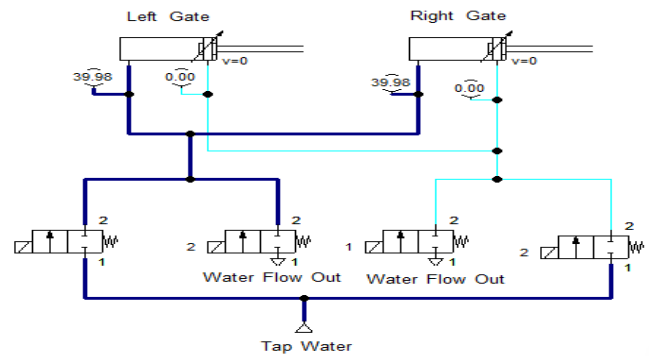

Fig. 3: Hydraulic Circuit of the Project by Using FluidSIM

Fig. 3 shows the system hydraulic circuit of the project using FluidSIM. A normal swing gate requires two double acting cylinders to open both side of the gate at once. The design of the circuit is shown in Figure 3.

After completing fabrication proses of each part, all parts will assemble as shown in Fig. 4 (a) and (b) for product testing. In overall, the testing was run smoothly and successful as planned. The fence can be open and closed automatically.



Fig. 4 (a) and (b): Fabrication and product testing for swing gate

### Simulation for sliding gate

For sliding gate type, an additional device that can extend the maximum reach of the piston cylinder is required. Fig. 5(a) shows the distance for 3 pairs with 500mm length and follow 4 pairs with 500 mm (Fig. 5(b)) and final design is 4 pairs of scissors with 700mm length (Fig. 5(c)). The measurement was taken between the surface of the block (red in colour) and the surface of gate.

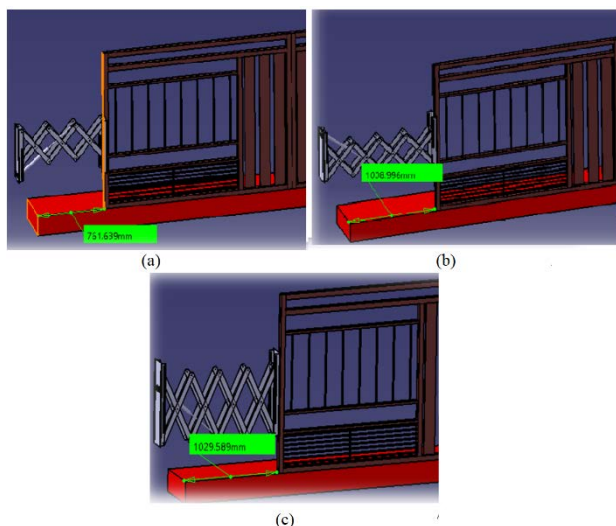

Figure 5 (a)(b) and (c): Simulation for sliding gate.

All the data of the distance are shown in Table 1 below. Among the three designs, design number 2 was chosen as the best design. One of the factors why design number 2 is the best even though design number 3 showed a longer in distance is because the material required for design 3 is more than those in design 2. Therefore, it is not worth it to get an extra 20mm with the exchange of more weight, space, material, and cost.

Table 1. Total travel distance for each design.

Design	Type	Travel distance[mm]	Different
1	3 Pairs of 500mm linkage	761.46	
2	4 pairs of 500mm linkage	1009.00	
3	4 pairs of 700mm linkage	1029.60	20.6

The distance travel by the actual gate when the gate was opened is shown in Fig. 6. The measuring tape showed that the length of the distance obtained from actual data is 760 mm. Meanwhile, simulation data obtained was 1009 mm which has 249 mm difference from the actual data. This experiment showed that the simulation data and actual data obtained for the distance of the gate travelled had a percentage of error of 24.7 %.



Fig. 6: Distance travel by the actual gate

#### Cost and power supply

This project is power by water pressure and used electric to control the flow of the water. Therefore, this

project main resource is water. The piston cylinder will extend and retract for every 1 cycle. During each of the motion, water will be extracted out of the piston cylinder. The amount of the water used for each cycle is 0.45L which is 0.25L to close the gate and 0.2L to open the gate for sliding gate but for swing gate the amount of water used is double (0.90 L) because swing gate need two piston cylinder. The detail of cost and the comparison with existing product (using electric motor) are shown in Table 2. Its show that the cost for existing product using electric motor is higher compare to the swing gate and sliding gate using tap water supply and remote control.

Table 2. Detail of cost and the comparison with existing product.

Existing product (using electric motor)	2.5 hours (0.5 min x 10 times/day x 30 days = 150 min) x 0.925 kW = 2.3125 kWh  2.3125 kWh x RM 0.218 (electric tariff/kWh) = <b>RM 0.504 per month</b>
Swing gate	Water supply 0.9 L/time x 10 times x 30 days = 270 L/month 270/1000 m <sup>3</sup> x RM 0.60/water tariff/m <sup>3</sup> = <b>RM 0.162/month</b> (note 1000 L = 1m <sup>3</sup> )
Sliding gate	Water supply 0.45 L/time x 10times x 30 days = 135 L/month 135/1000 m <sup>3</sup> x RM 0.60/water tariff/m <sup>3</sup> = <b>RM 0.081/month</b> (note 1000 L = 1m <sup>3</sup> )

Lastly, the product had been compared to existing product for the total cost and the power supply consumption. The overall cost required to build the project is cheaper compare to existing product. The overall cost to build both of gate using tap water around RM604 - RM821 while the total cost for existing product around RM1438 -RM 1450 about 50% lower. This project is much cheaper in price between exiting products because this project uses low-cost mechanical price component and without any electrical motor. Table 3 show the comparison overall price between the existing local/overseas product with swing and sliding gate using tap water as a power supply consumption.

Table 3. The comparison overall price

Local product (using motor)	Overseas product (using motor)	Swing gate	Sliding gate
<b>RM 1450</b> (Source: Dc Motor 925W Hybrid Auto gate.)	<b>RM 1438.05</b> (\$329.51) (Source: eBay)	<b>RM 821.25</b> (Include 2-unit double acting cylinder, solenoid valve, remote control etc.)	<b>RM 604.42</b> (Include 1-unit double acting cylinder, solenoid valve, remote control, material cost etc.)

#### 4. Conclusions

The main objectives of this project are to design devices that use water pressure as the power source to operate a swing gate and sliding gate used in every household. The fabrication of the device was successfully completed. The testing of the device was done at one of residential area, in Melaka where most of the houses in that area are using

swing gate and sliding gate. The device manages to move the gate as simulated in the simulation. For swing gate the result of the testing is successful because the double acting cylinder work as simulated. The water pressure does not need additional water pump to increase the pressure. From monitoring the water pressure, the minimum pressure was 33 psi and it is enough to actuate the common swing type fence. The main component of this project is double acting cylinder, solenoid valve and remote-control switch.

For sliding gate type the cylinder length is not long enough to open the sliding gate to the desired distance. Therefore, a scissor mechanism was fabricated, and the cylinder was attached to the scissor mechanism. As a result, the mechanism successfully achieved a longer distance that unreachable by the current size of the cylinder. The results which shown and prove that the distance travel is extendable. Before attaching to the mechanism, the cylinder was only able to achieve a maximum distance of 300 mm which was lower compared to after attach with scissor mechanism. The result from the simulation showed that the distance travel was slightly higher than the achieved actual distance by 249mm which equivalent to 24.68% of percentage of error. Therefore, the objective of this project to move the sliding gate and increase the distance of the gate to open are achieved.

Lastly, the product had been compared to existing product for the total cost and the power supply consumption. The total cost required to build the project is cheaper compare to existing product. The total cost to build current size of the scissor mechanism device is around RM 82.50. The component that has the highest cost for this project is double acting cylinder which cost around RM 280. Moving on, the water that flow out from the piston cylinder can be used for an automatic plant watering system.

### Acknowledgments

This works has initially been accepted and presented at the MERD'20. The authors would like to thank to the reviewer community who greatly help to produce this manuscript. Special thanks also to Universiti Teknikal Malaysia Melaka for support this research.

### References

- 1) Kiyoshi Toko. "Biomimetic Sensor Technology," Cambridge University Press, (2004).
- 2) Faiz Aswad. "Design and Analysis of Hydraulic House Fence Opening Using Tap Water Pressure," Thesis Bac. of Mechanical Engineering Universiti Teknikal Malaysia Melaka, (2018).
- 3) A. Hadi, F.C.Yang, S.M.Kit, L.K.Sing, M.Ikhwan, Design and Development of Low Cost Auto Gate System for House, Part 4, 2nd Integrated Design Project Conference (IDPC), Faculty of Mechanical Engineering, Universiti Malaysia Pahang, (2015).
- 4) Loidolt, Peter, "Ceta Elektromechanik GmbH, Sliding Gate". E.U. Patent No. EP3228791. (2017).
- 5) M. Hagaman (2013). "Autogate Swing Arm Type," Available at: <https://securetypesystem.wordpress.com/autogate-swing-arm-type/>(Accessed on 15 October 2016)
- 6) Nathan David, Abafor Chima et al. "Design of a Home Automation System Using Arduino," *International Journal of Scientific and Engineering Research* 6(6) (2015).
- 7) Engel, G.L., et al., "Automatic power control system which automatically activates and deactivates power to selected peripheral devices based upon system requirement," Google Patents (1988).
- 8) Merensky, K., "Water Conservation by means of an Automatic Water Level Control System" (1985).
- 9) Petite, T.D. and R.M. Huff, "System and method for monitoring and controlling remote devices," Google Patents (2002).
- 10) Spaur, C.W., et al., "Mobile portable wireless communication system," Google Patents (1998).
- 11) Mishra, Y., G.K. Marwah, and S. Verma., "Arduino Based Smart RFID Security and Attendance System with Audio Acknowledgement," *International Journal of Engineering Research and Technology*. ESRSA Publications (2015).
- 12) Javier, B., "Low cost AUV based on Arduino open-source microcontroller board for oceanographic research applications in a collaborative long term deployment missions and suitable for combining with an USV as autonomous automatic recharging platform Autonomous Underwater Vehicles (AUV)," IEEE/OS Southampton, UK. ISSN (2012).
- 13) Beni, N. et al., "Rapid prototyping of low cost 1 DOF haptic interfaces" Haptics Symposium (HAPTICS), IEEE, (2014).
- 14) Zungeru, A.M. and P.O. Abraham-Attah, "A Digital Automatic Sliding Door with a Room Light Control System," arXiv preprint arXiv:1303.1728 (2013).
- 15) Patil, S.P., J.R. Dhabuwala and L.A. Patel, "Automatic Sliding Window." (2019).
- 16) Yu, H. and M. Leiser. "Automatic sliding window operation optimization for FPGA-based. in Field-Programmable Custom Computing Machines," FCCM'06. 14th Annual IEEE Symposium on. (2006).
- 17) Imtiaz, A., Q.T.I. Masud, and Z.F. Chowdhury, "An automated railway system: railway network automation for Bangladesh railway," BRAC University (2014).
- 18) Islam, M., A. Halder, and F. Ahmed, "Enhancing security by Automatic Railway Gate Control using Microcontroller and IR Sensor," (2015).
- 19) Weaver, B., et al., "The failure of recall to prison: early release, front-door and back-door sentencing and the revolving prison door in Scotland," *European Journal of Probation*, 4(1): p. 85-98 (2012).

- 20) Nathan David, Abafor Chima, Aronu Ugochukwu and Obinna Edoga “Design of a Home Automation System Using Arduino,” *International Journal of Scientific & Engineering Research*, Volume **6** (6), 795 ISSN 2229-5518. 2015.
- 21) Yudan Whulanza, Taufik A. Hakim, Muhammad S. Utomo, Ridho Irwansyah, Jerome Charmet, Warjito “Design and Characterization of Finger-Controlled Micropump for Lab-on-a-Chip Devices,” *EVERGREEN Joint Journal of Novel Carbon Resource Sciences & Green Asia Strategy*, Vol. **06**, Issue 02, pp.108-113, June (2019).
- 22) M. M. Takeyeldein, Tholudin Mat Lazim, Nik Mohd, N.A.R, Iskandar Shah Ishak, Essam Abubakr Ali “Wind Turbine Design Using Thin Airfoil SD2030,” *EVERGREEN Joint Journal of Novel Carbon Resource Sciences & Green Asia Strategy*, Vol. **06**, Issue 02, pp.114-123, June (2019).
- 23) Mehak Sharma<sup>1</sup>, Manoj Soni “A musculoskeletal Finite Element Study of a Unique and Customised Jaw Joint Prosthesis for the Asian Populace,” *EVERGREEN Joint Journal of Novel Carbon Resource Sciences & Green Asia Strategy*, Vol. **07**, Issue 03, pp351-358, September, (2020).
- 24) Shailendra Singh Chauhan, S C Bhaduri “Structural analysis of a Four- bar linkage mechanism of Prosthetic knee joint using Finite Element Method” *EVERGREEN Joint Journal of Novel Carbon Resource Sciences & Green Asia Strategy*, Vol. **07**, Issue 02, pp209-215, June (2020).
- 25) Nagendra Kumar Maurya, Vikas Rastogi, Pushpendra Singh “Experimental and Computational Investigation on Mechanical Properties of Reinforced Additive Manufactured Component,” *EVERGREEN Joint Journal of Novel Carbon Resource Sciences & Green Asia Strategy*, Vol. **06**, Issue 03, pp207-214, September (2019).
- 26) Young-Deuk Kim, Kyaw Thu and Kim Choon Ng “Evaluation and Parametric Optimization of the Thermal Performance and Cost Effectiveness of Active Indirect Solar Hot Water Plants,” *EVERGREEN Joint Journal of Novel Carbon Resource Sciences & Green Asia Strategy*, Vol. **02**, Issue 02, pp50-60, September, (2015).
- 27) Hassan Taheri, Jonathan Becerra, “Viking Access Systems LLC, High torque gearless actuation at low speeds for swing gate, roll-up gate, slide gate, and vehicular barrier operators”. U.S. Patent No. US20090189560A1, (2008).