



Design Optimization & Analysis of a Soft Crawling Robot

Mariam Md Ghazaly^{1,2*}, Siti Norazlin Mohd Basar^{1,2}, Muhammad Shadiq Lagani^{1,2}

¹Centre for Robotics and Industrial Automation (CeRIA), Faculty of Electrical Engineering, Universiti Teknikal Malaysia Melaka, Hang Tuah Jaya, 76100 Durian Tunggal, Melaka, MALAYSIA

²Faculty of Electrical Engineering, Universiti Teknikal Malaysia Melaka, Hang Tuah Jaya, 76100 Durian Tunggal, Melaka, MALAYSIA

*Corresponding Author

DOI: <https://doi.org/10.30880/ijie.2021.13.06.025>

Received 25 November 2020; Accepted 08 June 2021; Available online 31 August 2021

Abstract: Soft crawling robots (SCRs) are the kind of robots that use soft and flexible material for motion. These soft robots capable to sustain huge distortions with vast degree-of-freedom which makes them more suitable to be employed in unstructured location compared to the conventional rigid robots. Unlike soft robotics, the conventional rigid robots are capable to be employed in situations where precision is required. However, soft robots are preferable in tight spaces such as in medical surgery and earthquake search and rescue operations due to its flexibility and adaptability capability. In this research, two types of soft robots were design using i.e.: (a) inchworm design and (b) quadrupedal design. The similarities between the inchworm and quadrupedal design are both use pressure input for motion. The SCRs also bend by using the expansion of chambers at their body. Both designs have the same length fixed at 86mm, but with different topology. The design optimization for maximum bending motion with respect to input pressure were evaluated using Finite Element Method (FEM) via Abaqus software, where the results shows that the highest bending was observed for the inchworm design. The maximum bending value (extension) of 130.4 mm was obtained with the optimized parameters set at 4mm base thickness, 5mm chamber gap, and 2mm width for the air chamber, respectively.

Keywords: Soft crawling robot, pressurized air, finite element method (FEM)

1. Introduction

Research on animal movements has been carried out since previous years and it was the crawling motion without limbs that caught researcher's attention as an efficient way of movement, in a delicate way. The soft crawling robots (SCRs) are in general composed of soft materials. The soft and simple design makes them reliable and safe, so that they can be used effectively in real life situations [1]. Majority of the designs of the soft robots are derived from the movements of invertebrates, which are animals without a backbone. These invertebrates animals do not have stiff body and skeleton so they are able to move freely [2]. These soft robots can move in a confined space place in a better motion in comparison to the conventional rigid robots [3]. Many kinds of actuators and constituents have been examined by the scholar in order to select the best design. Some of the latest designs created by the researcher focus on enabling the robots to adhere, stick or slip as per the requirements [4].

Unlike the animals with rigid skeletons, invertebrates' animal such as earthworms or caterpillars have soft structures that allow them to move with vast degree-of-freedom. Such animals can move more flexibly making them a significant subject for investigation for the real-life uses of these days. This soft robotics which is inspired by these creatures emphasize on designing these robots in such a manner that their movements can be easily regulated. Some of these robots

*Corresponding author: mariam@utem.edu.my

2021 UTHM Publisher. All rights reserved.

penerbit.uthm.edu.my/ojs/index.php/ijie

are employed for transportation of small loads due to their capacity to bear and move the loads. These soft robots can make movements in confined space making them preferable over the conventional rigid robots. The SCRs can make movement delicately since they have flexible structures that can sustain huge structural distortions [5].

Soft crawling robots (SCRs) are the kind of robots that use soft and flexible material for movement. Majority of the robots of this kind employ pneumatic concept due to high efficiency but require several accessories, therefore making them difficult to control. These soft robots can sustain huge distortions with vast degree-of-freedom which makes them more suitable to be employed in unstructured location compared to the conventional rigid robots. Unlike soft robotics, the conventional rigid robots are capable to be employed in situations where precision is required. However, soft robots are preferable in tight spaces such as in medical surgery and earthquake search and rescue operations due to its flexibility and adaptability capability. Basically, robots are employed to provide higher safety to the humans as they lower the possibility of harm to the humans by working in a hazardous environment in place of the humans. The main problem with the conventional rigid robots is that they are not flexible enough which renders them less safety for human interaction.

1.1 Types of Soft Crawling Robot Design

There are several kinds of soft robots, particularly in the crawling robot division. In this category, there are the earthworm robots, starfish-like robots, and the quadrupedal robots. The soft robots that resemble the starfish shape and are designed with a symmetrical framework [2, 6]. These robots can move across barriers due to its multiple rays. These robots have bendable rays, and they are made using the 3D printing technology with shape memory alloy (SMA) spring embedded inside it for regulating the movement. The design of the mechanism was derived from living creatures, which possess soft skeletons. The drawback of the robots with such a design is that they are only able to make movement on a flat plane because of their structural limitations [2]. The starfish of the ocean have huge distortions and can adjust to unstructured surroundings easily [7]. Fig. 1 shows the starfish-like robot structure [2].

In contrast, earthworm robots use peristalsis wave movement and friction from their body against the surface of the ground to move in a straight line [8]. These earthworm robots have metamers, or, in other words, their bodies have segmented units that allow them to move. The contraction and expansion of muscles create peristalsis waves. With the help of both these mechanisms, the robot can crawl using pneumatically powered soft actuators. An earthworm-inspired burrowing robot utilising the same mechanism is illustrated in [9]. Since the worm robot was designed for pipe inspection purposes, its movement is limited within the constrained tube. Optimization of the design can be done to build more versatile robots that can be utilised for various applications [8]. However, one of its disadvantages is that it is only able to crawl on a flat surface [8, 9]. Fig. 2 shows the earthworm inspired soft robot and soft burrow earthworm robot [8, 9].

Numerous studies have been inspired by the inchworm mechanism of inching and crawling locomotion systems [10]. It utilizes a mechanism similar to the caterpillar-like soft robots due to their familiar shape [11]. This is an ideal design for transport functions in congested spaces. The robot only has a single degree of freedom and only one material is used, which is silicone. This robot moves via continuous locomotion using air pressure. The inchworm design is equipped with a chamber that allows the robots to bend as it expands. Furthermore, the inchworm robots are only able to move in a straight line. Fig. 3 shows the inchworm robot compared to a real inchworm and the inchworm design [10, 12].

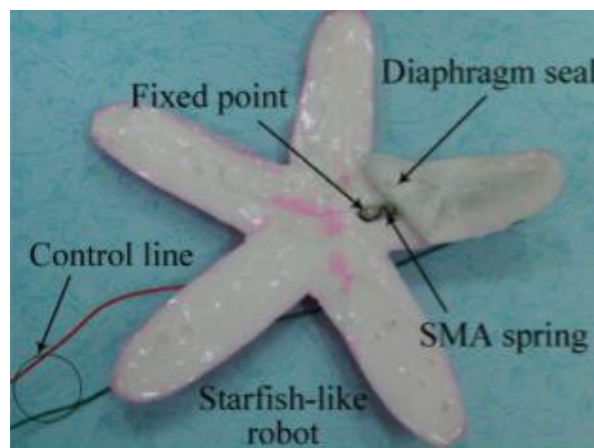

Fig. 1 - Starfish-like robot [2]

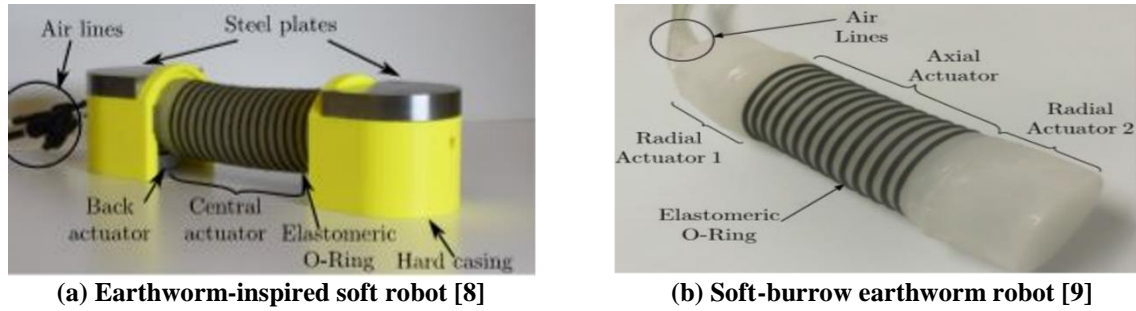

Fig. 2 - Earthworm soft robot design

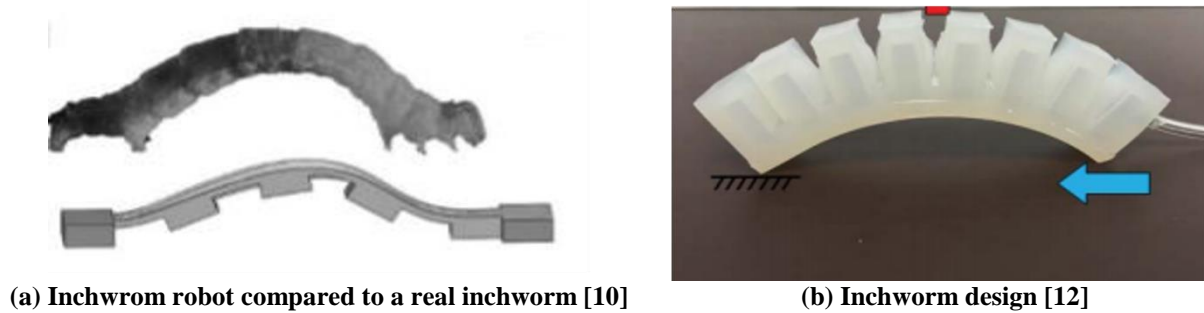

Fig. 3 - Inchworm soft robot design

Quadrupedal robots utilize inflate mechanisms to move. It rhythmically inflates its legs so it can move in favorable direction and motion. The robot does not utilize sensors and instead utilizes five actuators with simple pneumatic valving. Quadrupedal robots are capable to navigate through obstacle due to its multiple legs. However, the disadvantage that comes with using this type of robots is that they have the tendency to be exposed to punctures and cuts from shape objects. The basis of the design is the Pneu-net (PN) design [14]. The body of the robots is inflated using pressurized air that also thins their walls. The air pressure will also increase the volume of the channels. The inflation of the chamber within the body allows it to expand and makes motion possible. Fig. 4 shows the quadrupedal robot structure [13].



Fig. 4 - Quadrupedal robot [13]

1.2 Types of Materials

Elastomers are a commonly used material for soft robotics since it imparts the elasticity that is required by a soft actuator. [15]. The soft robots utilized EcoFlex 00-30 as their primary materials because it imparts the required properties [9, 15]. Fabrication of the burrowing worms is done using 3D-printed molds, butadiene rubber elastomeric O-rings, and EcoFlex 00-30 [9]. This silicone is an elastic platinum-catalyzed silicone that is easy to handle. The material exhibits zero shrinkage and can undergo curing at room temperature. It has a tensile strength value of 200 psi under a cure time of 4 hours. Elastosil® RT 622 can be cured at room temperature. The primary applications of this material are for encapsulation of electrical and electronic components, making moulds, and coating and production of technical moulded parts by casting [16]. For the soft actuator used in [16], construction of the main elastic body is executed using these materials due to their characteristics. The robot body is made up of multiple chambers that are assemble together to make a complete soft robot [17]. This material has a tensile strength value of 942.745 psi. This material has a curing time of 12 hours.

1.3 Types of Optimizations

The Soft Crawling Robot in [18-21] moves using the inchworm design. This study examined the optimization for the bending elongation of the robot using finite element method (FEM) analysis. To alter the bending elongation of the soft robot, the value of the air volume was varied from 10 ml to 30 ml [19]. Fabrication of the soft crawling robot was done using silicone elastomer, hollow glass microspheres, and polyaramid fabric [22]. The robot carried the miniature air compressors that in turn enabled its movement. To determine the maximum load that the robot could hold, the pressure within the robot was varied [22]. To find the most appropriate material, the material utilized was also varied. The soft crawling robot is shaped like an earthworm and it also mimics the muscle movement functions of an earthworm. It moves by contracting and expanding its body. To examine the deformation of the soft robot, pressure was also varied [9].

2. Construction and Design of the Soft Actuator

The flowchart in Fig. 5 illustrates the analysis and optimization processes for the two designs, i.e.: (a) inchworm design and (b) quadrupedal design. The first steps to optimize the design involves the creation of two designs based on robot specifications. Next steps involve the analysis and optimization of the robots through the Finite Element Method (FEM) using Abaqus simulation. The similarities between the inchworm and quadrupedal design are both designs use pressurized air to move. The robots also bend by using the expansion of chambers at their body. Both design use silicone to fabricate and design with the same length, which fix at 86mm. The base of both robots also consists of paper that will allow them to bend when pressurized. The differences between the Inchworm design with Quadrupedal design are inchworm has only one part of body while quadrupedal has main body and four legs. Table 1 shows the difference and similarities between both designs.

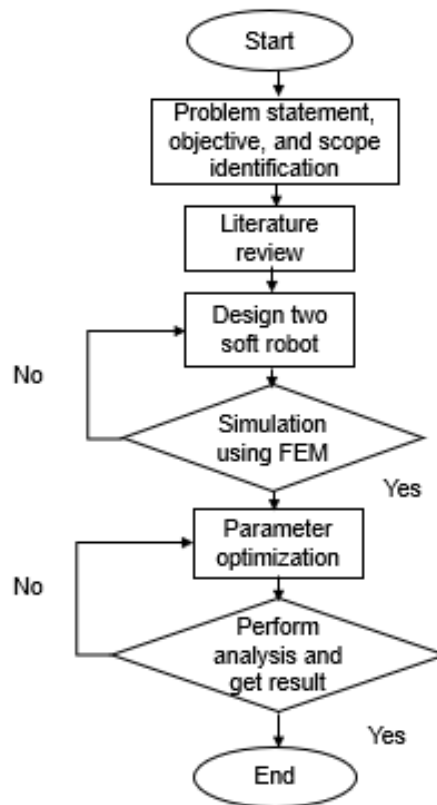

Fig. 5 - Flowchart of design and analysis of soft crawling robot

Table 1 - Difference and Similarities between both designs

Design	Difference	Similarity (Design Specification)
Inchworm	Has only one part of body	Design with same length. Use pressurized air to move.
Quadrupedal	Has main body and 4 legs	Bending elongation by using the expansion of chambers. Both use silicone to fabricate.

2.1 Soft Crawling Robot Design

Based on the inchworm mechanism, the inchworm soft crawling robot design was selected as the first design to be optimized. The body of the robot is made up of chambers that undergo expansion under pressure. The chambers' lower parts are equipped with air gap holes. These holes are connected in such a way that when there is pressure applied, every chamber will be included. The robot will then move via the contraction and expansion of the chambers. The body of an inchworm robot is made up of a main body and a base. The inchworm's base has a paper that allows for the bending elongation of the robot under pressure. Fig. 6 illustrates the inchworm soft crawling robot. Fig. 7 and Fig. 8 shows the technical drawing for the main body and base. The hollow parts in Fig. 7 indicates the air chambers.

The second design to be optimized is the quadrupedal soft crawling robot, which refers to a soft robot with four legs and one body. Within the robot are air chambers that expand under pressure. The robot's base is also made up of paper that allows it to bend. Fig. 9 illustrates the Quadrupedal Soft Crawling Robot. Fig. 10 and Fig. 11 shows the technical drawing for the main body and base. The hollow parts in Fig. 10 indicates the air chambers. Both the inchworm and quadrupedal designs use pressurized air for motion. Furthermore, the robots bend by utilizing the expansion of chambers within their body. The two designs also have the same length, which is fixed at 86mm. The two robots have a base that consist of paper, which as a constraining element allowing them to bend under pressure. However, unlike quadrupedal soft crawling robots that have one main body and four legs, inchworm soft crawling robots only have one body part. In order to have a forward motion, in general the soft robot should be fabricated to have a sharp-edged front bottom, and a chamfered back bottom edge. The design was done in such a way so that the front end has a different friction coefficient value when the robot bends up and down, allowing for locomotion to take place. Fig. 12 shows an example of the back bottom (back leg) that is chamfered to add friction and the full cycle of the locomotion of the inchworm soft robot [12]. Based on this friction concept, the designs for the two soft crawling robots, the inchworm and quadrupedal design have chamfered back legs after fabrication to help achieve the forward locomotion under pressure.

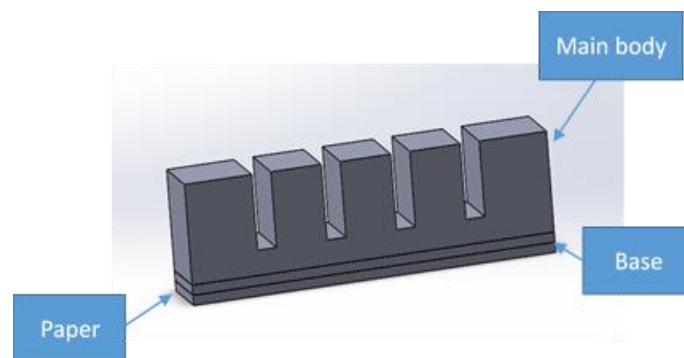
**Fig. 6 - Inchworm soft crawling robot design**

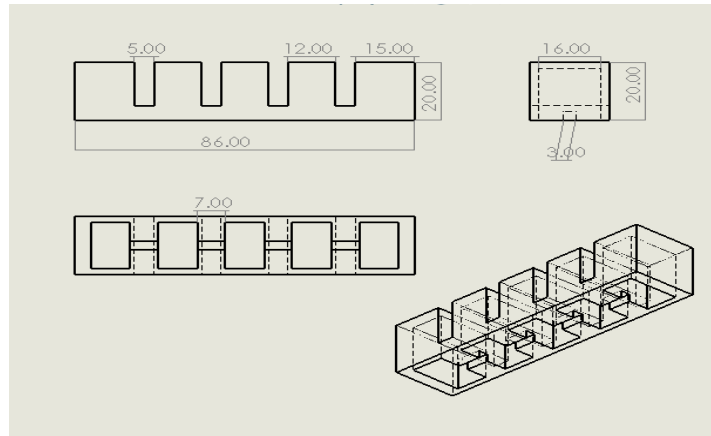

Fig. 7 - Main Body technical drawing (in mm)



Fig. 8 - Base technical drawing

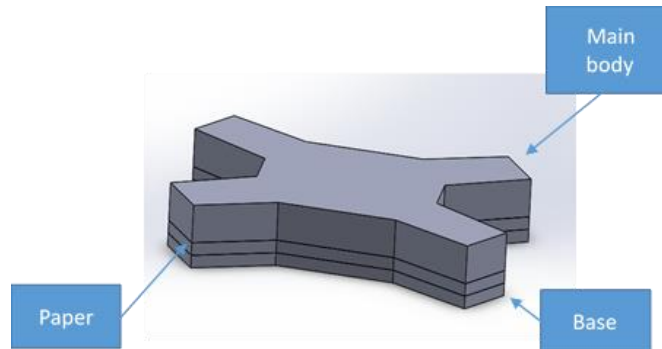

Fig. 9 - Quadrupedal soft crawling robot design

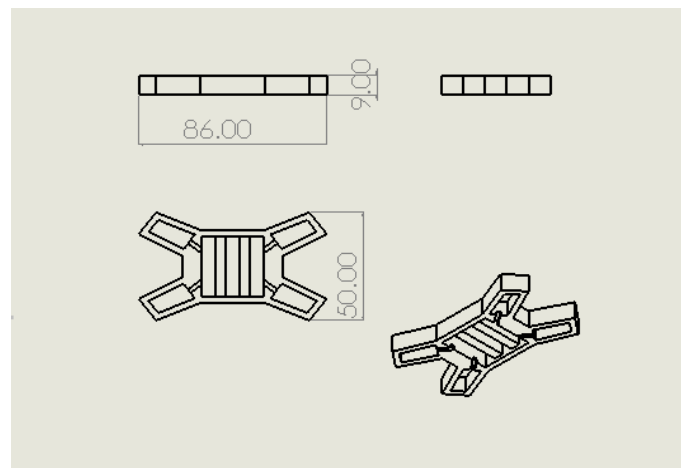

Fig. 10 - The dimension of the body of quadrupedal soft crawling robot (in mm)

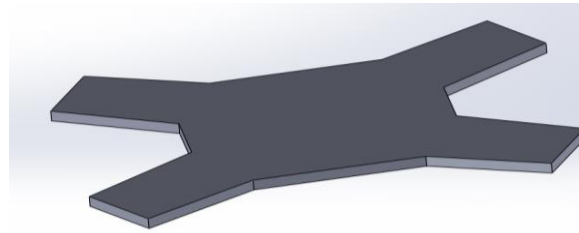

Fig. 11 - The base of quadrupedal soft crawling robot

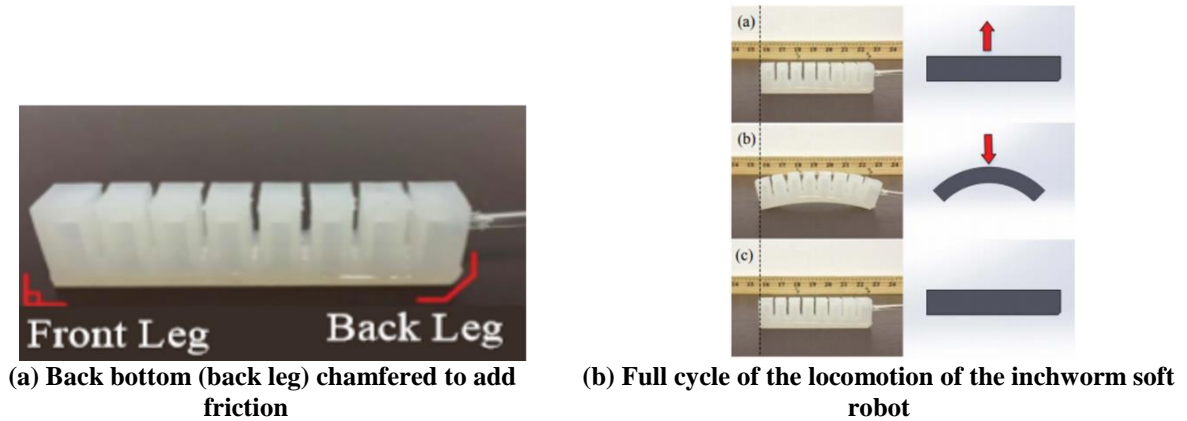

Fig. 12 - Soft crawling robot locomotion phase [12]

2.2 Assembly procedure of the Soft Crawling Robot

SolidWorks software is used for the design and assembly of the soft crawling robot. Fig. 13 shows the four (4) step procedures for assembly process of the inchworm soft crawling robot. To fabricate the main body of the robot, silicone is poured into the main body mould. A strain limiting paper, along with the silicone, is then put at the base mould. The remaining silicone is then poured into the base mould to attach the main body. Curing of the main body is then done before it is demoulded. A silicone tube is used to connect the soft crawling robot to the compressor in order to actuate the robot by pressurized air. A solenoid valve is used to control the pressure so that the main body can deflate and inflate accordingly, hence giving forward motion to the robot. To ensure locomotion of the soft crawling robot, the robot's back leg is cut with an angle (chamfered) after fabrication process to enhance the friction between the soft robot and its surface. This concept is applicable to both designs, the inchworm design and the quadrupedal design.

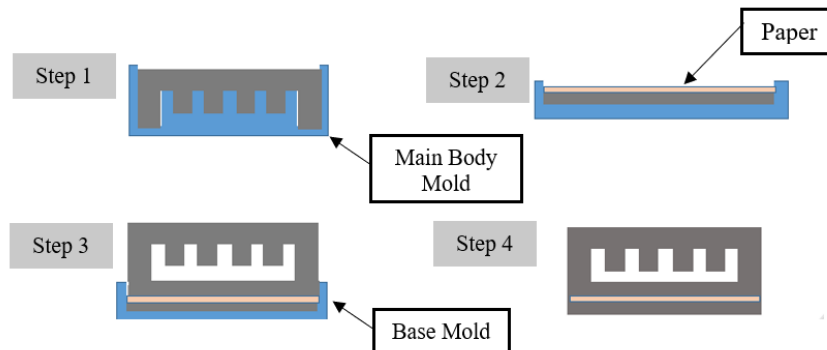

Fig. 13 - Four (4) step procedures for assembly process of inchworm soft crawling robot

2.3 Parameter Optimization

After the completion of the design of inchworm design and quadrupedal design using SolidWorks, the analysis of design and its optimization is carried out using the Abaqus software. In this research, the Abaqus software is used for the Finite Element Method (FEM) analysis of the Soft Crawling Robots (SCRs). FEM enables the modelling of the behaviour of the actuator and assesses the influence of different varying parameters such as chamber dimensions and material

stiffness. The steps involved in the FEM analysis of the design of SCRs begin with importing the robot parts in the Abaqus as a STEP file. Thereafter, at the base part of the robot, the placeholder surface is developed for the paper layer. Then the material attributes are assigned to the parts of the design. Table 2 shows the properties of elastosil and paper used in the analysis. Next, before setting the boundary conditions, the loads such as pressure and gravity are applied on the inner cavity. Finally, the contact interaction and creation of the mesh to perform the FEM analysis. Silicone elastosil is identified as the material to be used for the main body of the robot because the robot is required to withstand the pressure of air to inflate. At the base of the main body, the limiting strain is added, so that the robot bends upward when it is inflated.

For inchworm design, air chamber width, base thickness and chamber gap are the parameters that will be optimized. The initial dimensions for the inchworm design are (a) chamber gap = 2mm, (b) based thickness = 2mm, and (c) air chamber width = 2mm, respectively. Table 3 presents the lists of parameters that enable optimization of inchworm design, where for each analysis one (1) parameter will be varied while the other two (2) parameters will be fixed. For the quadrupedal design, the parameters that selected for optimization include air chamber width, number of chambers, and base thickness. The initial dimensions for the quadrupedal design are (a) chamber gap = 2mm, (b) number of chambers = 3, and (c) air chamber width = 2mm, respectively. Table 4 presents a list of parameters that can enable optimizations of the design of quadrupedal design. Based on the FEM analysis, the optimize design will be chosen based on the design that will produce the maximum bending elongation. In this research, the two-design specification were compared by fixing it at the similar robot length, i.e., length is fix at 86mm.

The primary aim is to derive the best design in terms of efficiency and appearance by varying different parameters. With the application of a range of input pressure values from 1psi to 8psi, the bending elongation value and von mises stress level are compared and analysed. The von mises stress is evaluated to determines if the material will yield or fracture when applied pressurized air between 1psi to 8psi. In this research, pressure is used as the dependent variable and the outcomes are recorded through a range of pressure values. The responding variables that are analysed include the level of stress and bending elongation of the robot design.

Table 2 - Properties of materials

Elastosil	Paper
<ul style="list-style-type: none"> • Yeoh strain energy potential defined by the coefficients $C_{10} = 0.11$, $C_{20} = 0.02$. • Density of 1130 Kg/m³, assumed isotropic 	<ul style="list-style-type: none"> • Density of 750 Kg/m³, a Young's Modulus of 6.5 GPa and a Poisson's ratio of 0.2

Table 3 - List of parameters optimization for inchworm design

Varied Parameter	Fixed parameter
Base thickness (2mm, 4mm, 6mm)	<ul style="list-style-type: none"> • Chamber gap (5mm) • Air chamber width (2mm)
Chamber gap (5mm, 4.5mm, 4mm)	<ul style="list-style-type: none"> • Base thickness (2mm) • Air chamber width (2mm)
Air chamber width (3mm, 2.75mm, 2.5mm)	<ul style="list-style-type: none"> • Base thickness (2mm) • Chamber gap (5mm)

Table 4 - List of parameters optimization for quadrupedal design

Varied Parameter	Fixed parameter
Base thickness (2mm, 3mm, 4mm)	<ul style="list-style-type: none"> • Number of chambers (3) • Air chamber width (2mm)
Number of chambers (1, 2, 3)	<ul style="list-style-type: none"> • Base thickness (2mm) • Air chamber width (2mm)
Air chamber width (2mm, 3mm, 4mm)	<ul style="list-style-type: none"> • Base thickness (2mm) • Number of chambers (3)

3 Results and Discussion

3.1 FEM Analysis of the Inchworm Design

The design for the soft crawling robot is conducted by utilising the SolidWorks software, and the von mises stress and bending elongation analysis via FEM are achieved using Abaqus software. The pressure employed to the robot is

ranging from 1psi to 8psi. The fixed side is at the back end of actuator. The initial dimensions for the inchworm design are (a) based thickness = 2mm, (b) chamber gap = 5mm, and (c) air chamber width = 2mm. For the FEM analysis, the based thickness parameter is varied according to Table 3, i.e.: 2mm, 4mm and 6mm, respectively. The graphs in Fig. 14 depicts the outcomes of pressure against von mises stress and bending elongation for the based thickness parameter. Table 5 depicts the summary for the von mises stress and bending elongation of the inchworm design after pressure is exerted. The maximum von mises stress attained is at 60.90MPa at pressure interval 8 psi for base thickness 2mm and the maximum bending attained at 130.40mm for based thickness value 4mm.

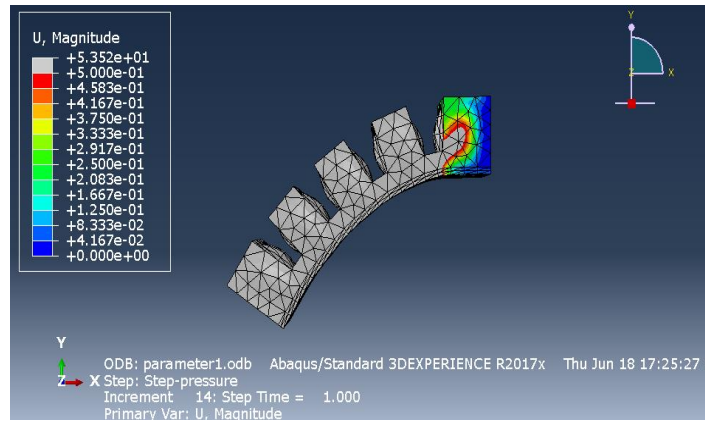

(a) Example of FEM via Abaqus for inchworm design

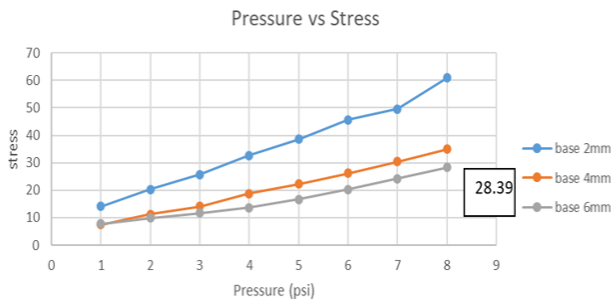

(b) Pressure vs. von mises stress

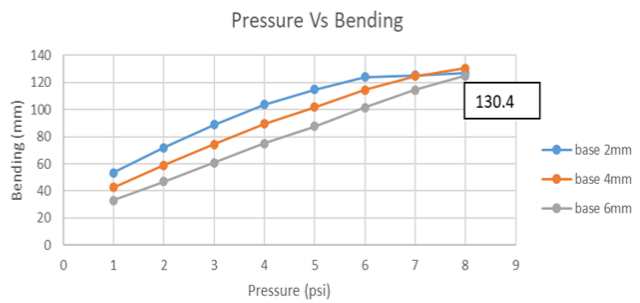

(c) Pressure vs. bending elongation

Fig. 14 - Optimization graphs for based thickness

Table 5 - Result for inchworm soft robot FEM

Parameters	Optimize value (maximum stress and maximum bending elongation) vs pressure			
	Stress (von mises, MPa)	Pressure (psi)	Bending elongation (mm)	Pressure (psi)
Based thickness = 2mm	60.90	8	127.10	8
Based thickness = 4mm	34.93	8	130.40	8
Based thickness = 6mm	28.39	8	124.90	8

Next, the FEM analysis is executed by varying the chamber gap shown in Fig. 15. The chamber gap is varied according to Table 3, i.e.:5mm, 4.5mm and 4mm, respectively. Table 6 depicts the summary for the von mises stress and bending elongation of the inchworm design. Based on the graph, the maximum stress at pressure interval 8psi is at 60.90MPa for chamber gap 5mm. The maximum bending elongation attainable is 127.10mm at pressure interval 8 psi for chamber gap 5mm.

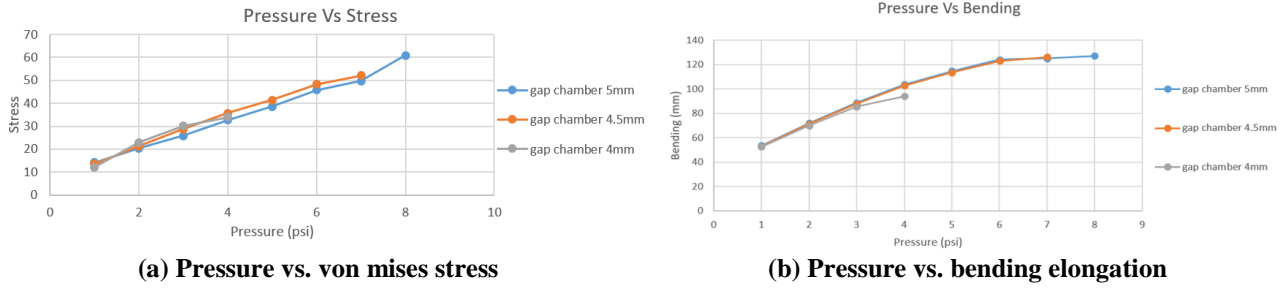

Fig. 15 - Optimization graphs for chamber gap

Table 6 - Result for inchworm soft robot FEM

Parameters	Optimize value (maximum stress and maximum bending elongation) vs pressure			
	Stress (von mises, MPa)	Pressure (psi)	Bending elongation (mm)	Pressure (psi)
Chamber gap = 5mm	60.90	8	127.10	8
Chamber gap = 4.5mm	52.17	7	126.30	7
Chamber gap = 4mm	33.90	4	94.020	4

The last parameter to evaluate for the inchworm is the air chamber width. The air chamber width is varied according to Table 3, i.e.: 3mm, 2.75mm and 2.5mm, respectively. Fig. 16 depict the outcomes of pressure against bending elongation and von mises stress for the air chamber width parameter. Table 7 depicts the summary for the bending elongation and von mises stress of the inchworm design when pressure is exerted. Based on the analysis, the maximum von mises stress selected is at 60.90MPa at pressure interval 8 psi for air chamber width 3mm. The maximum bending elongation which is obtained at 127.40mm at pressure interval 7 psi for air chamber width 2.75mm.

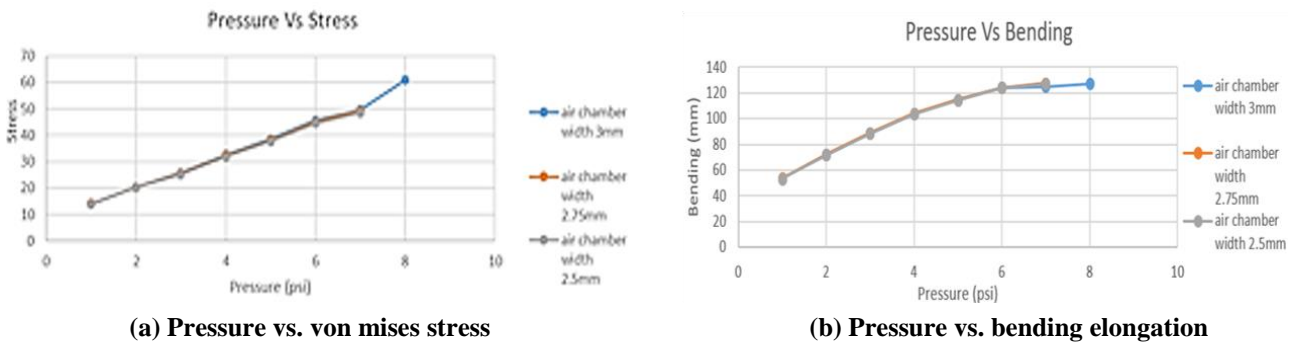

Fig. 16 - Optimization graphs for air chamber width

Table 7 - Result for inchworm soft robot FEM

Parameters	Optimize value (maximum stress and maximum bending elongation) vs pressure			
	Stress (von mises, MPa)	Pressure (psi)	Bending elongation (mm)	Pressure (psi)
Air chamber width = 3mm	60.90	8	127.10	8
Air chamber width = 2.75mm	49.07	7	127.40	7
Air chamber width = 2.5mm	48.50	7	127.30	7

3.2 FEM Analysis of the Quadrupedal Design

Similar to the FEM analysis done to the inchworm design, the quadrupedal design was also evaluated for comparison to further select the best design. The initial dimensions for the quadrupedal design are (a) based thickness = 2mm, (b)

number of chambers = 3, and (c) air chamber width = 2mm. Fig. 17 depict the outcomes of pressure against von mises stress and bending elongation for the based thickness parameter. The base thickness parameter is varied according to Table 4, i.e.: 2mm, 3mm and 4mm, respectively. Table 8 depicts the summary for the von mises stress and bending elongation of the quadrupedal design after pressure is exerted. Based on Fig. 17, the maximum von mises stress attained is at 143.70MPa at pressure interval 7 psi for base thickness 2mm. The maximum bending elongation attainable is 41.73mm at pressure interval 8 psi for base thickness of 2mm.

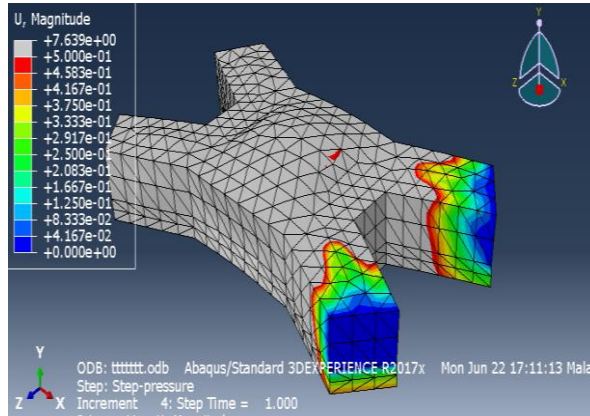

(a) Example of FEM via Abaqus for quadrupedal design

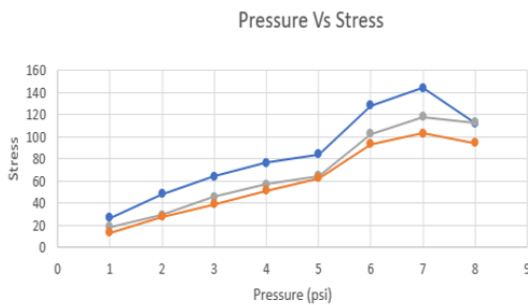

(a) Pressure vs. von mises stress

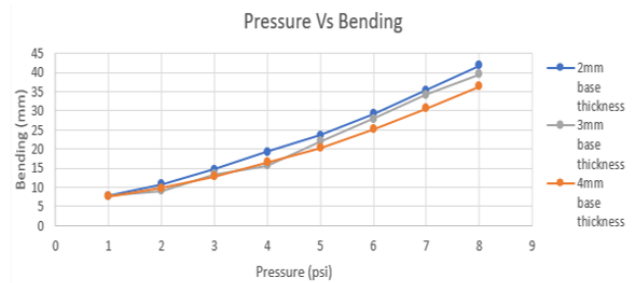

(b) Pressure vs. bending elongation

Fig. 17 - Optimization graphs for based thickness

Table 8 - Result for quadrupedal soft robot FEM

Parameters	Optimize value (<i>maximum stress and maximum bending elongation</i>) vs pressure			
	Stress (von mises, MPa)	Pressure (psi)	Bending elongation (mm)	Pressure (psi)
Based thickness = 2mm	143.70	7	41.73	8
Based thickness = 3mm	117.88	7	39.47	8
Based thickness = 4mm	103.10	7	36.41	8

Furthermore, the FEM analysis was also evaluated by varying the number of chambers for the quadrupedal design. The number of chambers varied was 3 chambers, 2 chambers and 1 chamber, respectively as shown in Table 4. Table 9 depicts the summary for the von mises stress as well as bending elongation of the quadrupedal design. According to the FEM anlysis shown in Fig. 18, the maximum von mises stress is at 143.70MPa at pressure interval 7 psi for 3 chambers. The maximum bending elongation evaluated is 44.06mm at pressure interval 8 psi for a single chamber.

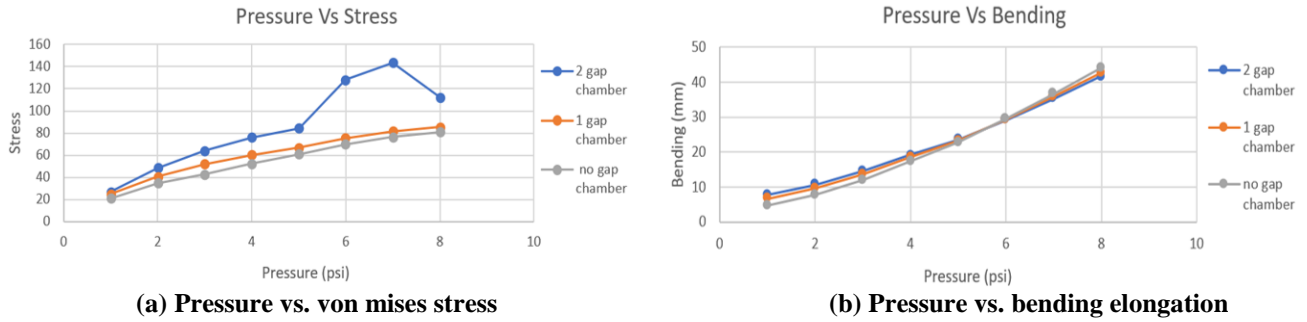

Fig. 18 - Optimization graphs for number of chambers

Table 9 - Result for quadrupedal soft robot FEM

Parameters	Optimize value (<i>maximum stress and maximum bending elongation</i>) vs pressure			
	Stress (von mises, MPa)	Pressure (psi)	Bending elongation (mm)	Pressure (psi)
Number of chambers = 3	143.70	7	41.73	8
Number of chambers = 2	85.51	8	42.71	8
Number of chambers = 1	80.73	8	44.06	8

Finally, the air chamber width was also varied and evaluated via FEM analysis according to Table 4, i.e.: with the value of 2mm, 3mm, and 4mm, respectively. Fig. 19 shows the optimization value for varying air chamber width. Table 10 depicted that the summary for the bending elongation and von mises stress of the quadrupedal design, when air chamber width is varied. According to the results, the maximum von mises stress is at 143.70Mpa at a pressure interval 7 psi, for a 2mm width of the air chamber. The maximum bending elongation is obtained at 42.56mm at a pressure interval 8 psi for a 3mm air chamber width.

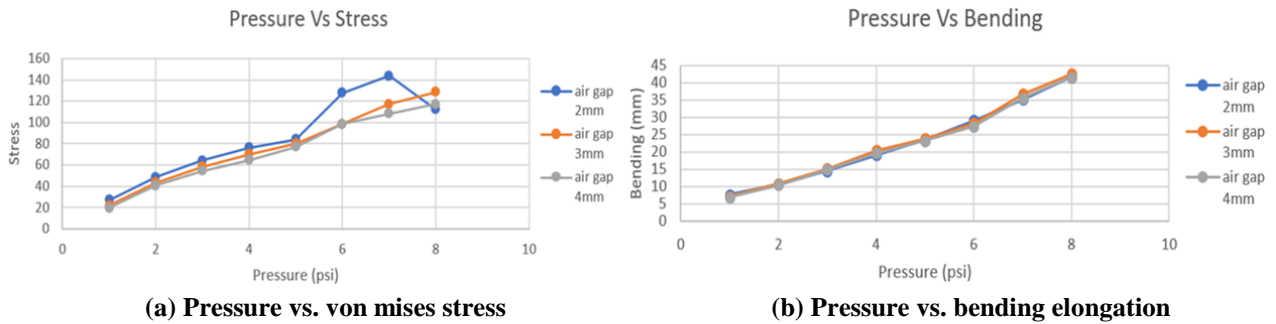

Fig. 19 - Optimization graphs for air chamber width

Table 10 - Result for quadrupedal soft robot FEM

Parameters	Optimize value (<i>maximum stress and maximum bending elongation</i>) vs pressure			
	Stress (von mises, MPa)	Pressure (psi)	Bending elongation (mm)	Pressure (psi)
Air chamber width = 2mm	143.70	7	41.73	8
Air chamber width = 3mm	128.60	8	42.56	8
Air chamber width = 4mm	117.20	8	41.69	8

3.3 Design Optimization Summary

This section summarises the parameter optimization of both inchworm design and quadrupedal design. Regarding the design optimization, the aspect of bending elongation is more significant in comparison to von mises stress, as the movement of soft robot progresses according to bending elongation values. Therefore, the superior scheme is selected with reference to the bending elongation values based on the discussion obtained from Table 5 to Table 10. Table 11 shows the conclusions of the selected parameter optimization. The highest bending elongation observed is for the inchworm design at a value of 130.40 mm. The optimized parameters for this comprise 4mm base thickness, 5mm chamber gap, and 2mm width for the air chamber, with the input pressure 8psi. The scheme of the quadrupedal design features a lower bending elongation value at 44.06mm, with an input pressure 8psi. This could be due to that the quadrupedal design topology require more optimization due to its segmented chambers. As a summary based on Table 11, it can be summarised that of both the design, the optimized design is the inchworm soft crawling robot, due to its higher bending elongation value.

Table 11 - Summary of optimization

Robot design	Optimize value (<i>maximum stress and maximum bending elongation</i>)	
	Optimized parameter	Optimized parameter
Inchworm soft robot	Based thickness = 2mm	Based thickness = 4mm
	Chamber gap = 5mm	Chamber gap = 5mm
	Air chamber width = 2mm	Air chamber width = 2mm
	Pressure = 8psi	Pressure = 8psi
Quadrupedal soft robot	Based thickness = 2mm	Based thickness = 2mm
	Number of chambers = 3	Number of chambers = 1
	Air chamber width = 2mm	Air chamber width = 2mm
	Pressure = 7psi	Pressure = 8psi
	Stress (von mises, MPa)	Bending elongation (mm)
	60.90	130.40
	143.70	44.06

4 Conclusions

As a conclusion, the design, optimization, and analysis of two types of soft crawling robots were evaluated and discussed in this paper. The two designs that were selected further to be evaluated were the inchworm design and quadrupedal design. In this research, elastosil was selected as the material due to its higher tensile strength in comparison to others. SolidWorks software was used to design the soft crawling robot. Then, Abaqus software was further used to analyse and optimized the designs using the Finite Element Method (FEM). The FEM results presented is based on the bending elongation and von mises stress analysis results with respect to applied pressure. The optimized design that was selected is the inchworm design, with optimized parameters comprises of 4mm base thickness, 5mm chamber gap, and 2mm width for the air chamber, respectively for a maximum bending elongation of 130.4mm.

Acknowledgement

The authors wish to express their gratitude to Motion Control Research Laboratory (MCon Lab), Center for Robotics and Industrial Automation (CeRIA) and Universiti Teknikal Malaysia Melaka (UTeM) for supporting the research and publication. This research is supported by Ministry of Education Malaysia (MOE) under the Fundamental Research Grant Scheme (FRGS) grant no. FRGS/2018/FKE-CERIA/F00353.

References

- [1] Tang, X., Li, K., Liu, Y., Zhou, D., & Zhao J. (2019). A soft crawling robot driven by single twisted and coiled actuator. *Sensors and Actuators A: Physical*, 291, 80–86
- [2] Mao, S., Dong, E., Jin, H., Xu, M., Zhang, S., Yang, J., & Low, K. H. (2014). Gait study and pattern generation of a starfish-like soft robot with flexible rays actuated by SMAs. *Journal of Bionic Engineering*, 11(3), 400–411
- [3] Yeh, C. Y., Chou, S. C., Huang, H. W., Yu, H. C., & Juang, J. Y. (2019). Tube-crawling soft robots driven by multistable buckling mechanics. *Extreme Mechanics Letters*, 26, 61–68
- [4] Zhou, X., Majidi, C., & O'reilly, O. M. (2015). Flexing into motion: A locomotion mechanism for soft robots. *International Journal of Non-Linear Mechanics*, 74, 7–17
- [5] Wang, J., Fei, Y., & Liu, Z. (2019). Locomotion modeling of a triangular closed-chain soft rolling robot. *Mechatronics*, 57, 150–163
- [6] Cole, L. J. (1913). Direction of locomotion of the starfish (*Asterias forbesi*). *Journal of Experimental Zoology*, 14(1), 1–32
- [7] Kidawa, A. (2001). Antarctic starfish, *odontaster validus*, distinguish between fed and starved conspecifics. *Polar Biology*, 24(6), 408–410
- [8] Ge, J. Z., Calderon, A. A., & Perez-Arancibia, N. O. (2017). An earthworm-inspired soft crawling robot controlled by friction. 2017 IEEE International Conference on Robotics and Biomimetics (ROBIO)
- [9] Calderon, A. A., Ugalde, J. C., Zagal, J. C., & Perez-Arancibia, N. O. (2016). Design, fabrication and control of a multi-material-multi-actuator soft robot inspired by burrowing worms. 2016 IEEE International Conference on Robotics and Biomimetics (ROBIO)
- [10] Joyee, E. B., & Pan, Y. (2019). A fully three-dimensional printed inchworm-inspired soft robot with magnetic actuation. *Soft Robotics*, 6(3), 333–345
- [11] Li, G., Li, W., Zhang, J., & Zhang, H. (2015). Analysis and design of asymmetric oscillation for caterpillar-like locomotion. *Journal of Bionic Engineering*, 12(2), 190–203
- [12] Ning, J., Ti, C., & Liu, Y. (2017). Inchworm inspired pneumatic soft robot based on friction hysteresis. *Journal of Robotics and Automation*, 1(2), 54–63
- [13] Shepherd, R. F., Ilijevski, F., Choi, W., Morin, S. A., Stokes, A. A., Mazzeo, A. D., Chen, X., Wang, M., & Whiteside, G. M. (2011). Multigait soft robot. *Proceedings of the National Academy of Sciences*, 108(51), 20400–20403
- [14] Ilijevski, F., Mazzeo, A. D., Shepherd, R. F., Chen, X., & Whitesides, G. M. (2011). Soft robotics for chemists. *Angewandte Chemie*, 50(8), 1890–1895
- [15] Chossat, J. B., Park, Y. L., Wood, R. J., & Duchaine, V. (2013). A soft strain sensor based on ionic and metal liquids. *IEEE Sensors Journal*, 13(9), 3405–3414
- [16] Chen, W., Xiong, C., Liu, C., Li, P., & Chen, Y. (2019). Fabrication and dynamic modeling of bidirectional bending soft actuator integrated with optical waveguide curvature sensor. *Soft Robotics*, 6(4), 495–506
- [17] Case, J. C., White, E. L., & Kramer, R. K. (2002). Soft material characterization for robotic applications. *Soft Robotics*, 2(2), 80–87
- [18] Lee, H. K., Chang, S. I., & Yoon, E. (2009). Dual-mode capacitive proximity sensor for robot application: implementation of tactile and proximity sensing capability on a single polymer platform using shared electrodes. *IEEE Sens. J.*, 9(12) 1748–1755
- [19] Kramer, R. K., Majidi, C., Sahai, R., & Wood, R. J. (2011). Soft curvature sensors for joint angle proprioception. *IEEE Int. Conf. Intell. Robot. Syst.*, 1919–1926
- [20] Coyle, S., Majidi, C., LeDuc, P., & Hsia, K. J. (2018). Bio-inspired soft robotics: material selection, actuation, and design. *Extreme Mechanics Letter*, 22, 51–59
- [21] Elgeneidy, K., Lohse, N., & Jackson, M. (2016). Bending angle prediction and control of soft pneumatic actuators with embedded flex sensors – A data-driven approach. *Mechatronics*, 50, 234–247
- [22] Tolley, M. T., Shepherd, R. F., Mosadegh, B., Galloway, K. C., Wehner, M., Karpelson, M., Wood, R. J., & Whitesides, G. M. (2014). A resilient, untethered soft robot. *Soft Robot*, 1(3), 213–223