

DOI: [https://dx.doi.org/10.21123/bsj.2021.18.4\(Suppl.\).1397](https://dx.doi.org/10.21123/bsj.2021.18.4(Suppl.).1397)

Evaluation Method of Mesh Protocol over ESP32 and ESP8266

Nur Azzurin Afifie¹ Adam Wong Yoon Khang^{*1} Abd Shukur Bin Ja'afar²
Ahmad Fairuz Bin Muhammad Amin¹ Jamil Abedalrahim Jamil Alsayaydehahmad¹
Win Adiyansyah Indra¹ Safarudin Gazali Herawan³ Arnidza Binti Ramli⁴

¹Broadband & Networking Research Group (BBNET), Center for Telecommunication Research and Innovation, Faculty of Electrical & Electronic Engineering Technology (FTKEE), Universiti Teknikal Malaysia Melaka (UTeM), Hang Tuah Jaya, Melaka, Malaysia

²Center for Telecommunication Research & Innovation (CeTRI), Faculty of Electronic and Computer Engineering (FKEKK), Universiti Teknikal Malaysia Melaka (UTeM), Hang Tuah Jaya, Melaka, Malaysia

³Industrial Engineering, Department Faculty of Engineering Bina Nusantara University, Jakarta, Indonesia

⁴Lightwave Communication Research Group(LCRG), Universiti Teknologi Malaysia, Johor Bahru, Malaysia

*Corresponding author: adamwong@utem.edu.my

E-mails: m022020020@student.utem.edu.my , shukur@utem.edu.my , ahmadfairuz@utem.edu.my , jamil@utem.edu.my , adiyansyah@utem.edu.my , safarudin.gazali@binus.edu , arnidza@utm.my

Received 14/10/2021, Accepted 14/11/2021, Published 20/12/2021



This work is licensed under a [Creative Commons Attribution 4.0 International License](https://creativecommons.org/licenses/by/4.0/).

Abstract:

Internet of Things (IoT) is one of the newest matters in both industry and academia of the communication engineering world. On the other hand, wireless mesh networks, a network topology that has been debate for decades that haven't been put into use in great scale, can make a transformation when it arises to the network in the IoT world nowadays. A Mesh IoT network is a local network architecture in which linked devices cooperate and route data using a specified protocol. Typically, IoT devices exchange sensor data by connecting to an IoT gateway. However, there are certain limitations if it involves to large number of sensors and the data that should be received is difficult to analyze. The aim of the work here is to implement a self-configuring mesh network in IoT sensor devices for better independent data collection quality. The research conducted in this paper is to build a mesh network using NodeMCU ESP 8266 and NodeMCU ESP 32 with two types of sensor, DHT 11 and DHT 22. Hence, the work here has evaluated on the delay performance metric in Line-of-Sight (LoS) and Non-Line-of-Sight (nLoS) situation based on different network connectivity. The results give shorter delay time in LoS condition for all connected nodes as well as when any node fail to function in the mesh network compared to nLoS condition. The paper demonstrates that the IoT sensor devices composing the mesh network is a must to leverage the link communication performance for data collection in order to be used in IoT-based application such as fertigation system. It will certainly make a difference in the industry once being deployed on large scale in the IoT world and make the IoT more accessible to a wider audience.

Keywords: IoT, LoS, Mesh Network, , nLoS, NodeMCU.

Introduction:

The IoT is a new area of technology that allows physical objects to communicate with one another, with the aim of making human life better and more convenient. The fundamental principle behind this concept is the omnipresent of diversity of sources– such as Radio-Frequency Identification (RFID) tags, sensors, tablets, wearable devices, and others – that are able to communicate with one another and collaborate with their peers to achieve mutual objectives due to special addressing schemes

¹. The quantity of IoT components with its devices rise by 31% last year to 8.4 billion, and is predicted to hit 7.1 billion in 2020 ². Using multisensory networks and other IoT devices, the Internet of Things can now collect data from varied locations and build control interfaces. This wireless mesh networking can make a big difference when it comes to the effective and efficient networking solutions in the IoT world today. Among the numerous benefits of mesh networks are their high

dependability, high bandwidth, cheap implementation cost, broad coverage, and excellent scalability^{3, 4}. Mesh networking is a local network topology in which nodes are individually, dynamically, and non-hierarchically linked to one another and work with others to route data from/to clients efficiently⁵. It also supports auto-networking meaning when the user setup a mesh network, any node can scan access point and can connect easily by form an artificial grid of APs to

intelligently direct traffic across the network^{6, 7}. Furthermore, the mesh networks are easier to build and manage than static network infrastructure. As a result, they are more convenient to install since they automatically adjust to the network settings, and the devices utilized combine two functions into a single device: routing and providing access to the network⁸. Without centralized control, these mesh routers are dynamically self-organizing, self-configurable, and self-healing⁹.

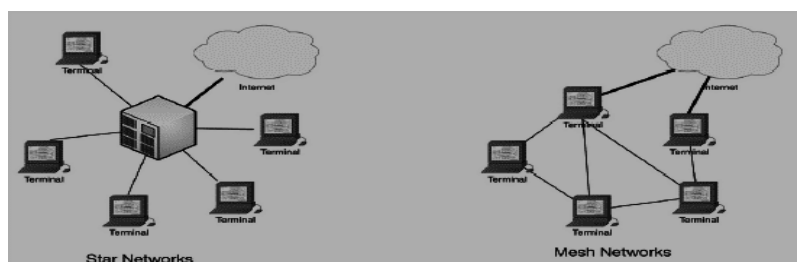

Figure 1. Wireless Mesh Network [5]

For static network, every device or node in the network typically has a dedicated point-to-point connection to every other node¹⁰. But when it comes to mobility, there are two kinds of wireless mesh network (WMNs): static mesh networks and mobile mesh networks¹¹. Usually, the routing data in a mesh network was taken care by the protocol itself. Under mesh network topology, guaranteed performance can be obtain with interconnection of all nodes^{12, 13}. The performance element metrics often used in quality assessment for mesh networks are hop count metrics, capacity metrics, delay metrics and others¹⁴. Generally, this paper carries the objective to demonstrate the performance proficiency of the mesh network idea in IoT connected network through the use of the ESP 32 and ESP 8266 for the remote monitoring purpose. The rest of the paper is organized as follow: the next section describes the related work. Follow by is the proposed method section and results section. Finally, is the conclusion section for the work here.

Related Work:

A mesh network with wireless feature consists of a number radio node that are arranged based on mesh configuration of communication network. Each node in WMNs is linked to one or more other nodes through multi-hop connections, allowing the network transmission to take place through more than one path¹⁵. The project proposed by¹⁶ create a Wi-Fi mesh network architecture for Internet of Things applications. This study's operating system is quick mesh project (QMP).

Based on the benchmarking, the study here has built a mesh network using the ESP32 and

Also, the role of the Wi-Fi node considered as a client for IoT applications. These nodes use MQTT to broadcast and subscribe. The Wi-Fi mesh architecture is functioning well, with an average throughput of 110.5 kbps. The development of a local wireless local area network connecting numerous nodes without the use of the internet was shown effectively here. As nodes are accountable for transmitting message to each other's, this mesh network architecture may support quite a wider number of nodes^{17, 18}. Hence, this paper has benchmarked the similar idea as in¹⁹. However, the author did not carry out the link performance. Hence, the work here would further extend the study by examining the delay time required to create the mesh network in LoS situation, nLoS and disconnect one node to show the efficiency of mesh network.

Proposed Work Methodology:

Table 1. List of parameters

Parameter	Specifications
Microcontroller	NodeMCU ESP 32 and NodeMCU 8266
Sensor	DHT 11 and DHT 22
Protocol	Dynamic Source Routing (DSR)
Power Voltage	3.3V
Communication	Bluetooth connection with half duplex mode
Topology	Full mesh (3 hops) and partially-mesh (2 hops) connected topology

provided 4 nodes without utilizing the internet or a router as shown in Figure 2. The table 1 had lists the

parameters utilized in this work. So, in this system architecture has implemented four independent NodeMCU boards for IoT framework. Both the NodeMCU runs on 3.3V. Technically based on the Figure 2, the four nodes would be communicating with each other by interacting with the input device

known as the sensors which are the DHT 11 and DHT 22. The sensors are used to measure temperature and relative humidity. The output device would be the computer which is to acquire the desired sensor output at each node.

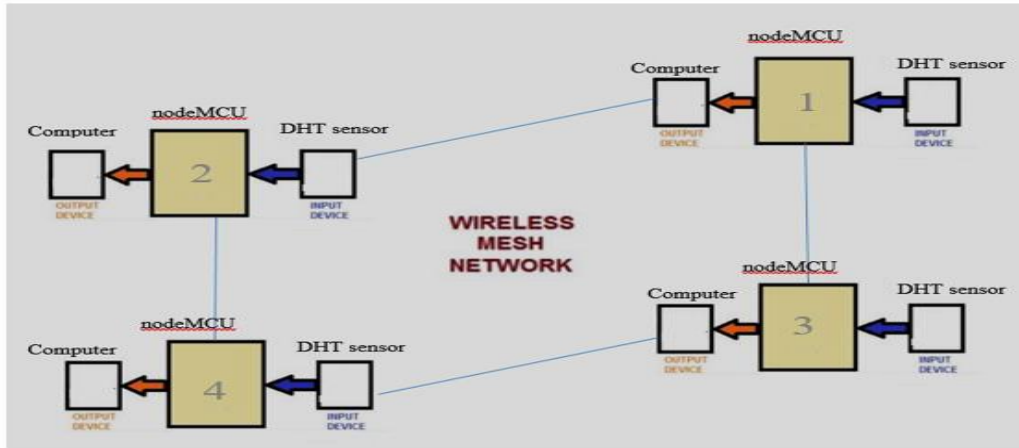

Figure 2. System Architecture

By applying the mesh topology in the IoT network is an efficient way in which the infrastructure nodes to maintain connectivity between these nodes. Specifically, the effectiveness of mesh networks will be shown through the delay performance metric in 2 conditions which were LoS and nLoS. The delay time is used to test how long all nodes react to

each other in a given situation and to indicate the mesh network is dynamic routing where it can select the fastest and safest route automatically. Furthermore, mean formula is used to calculate the delay time readings for nodes communicating with each other.

$$x, \text{ time taken between Nodes} = (\text{Node a} - \text{Node b}) + (\text{Node b} - \text{Node c}) + \dots$$

$$\text{mean, } m = \frac{\sum(x_1 + x_2 + x_3 + \dots)}{100} \tag{1}$$

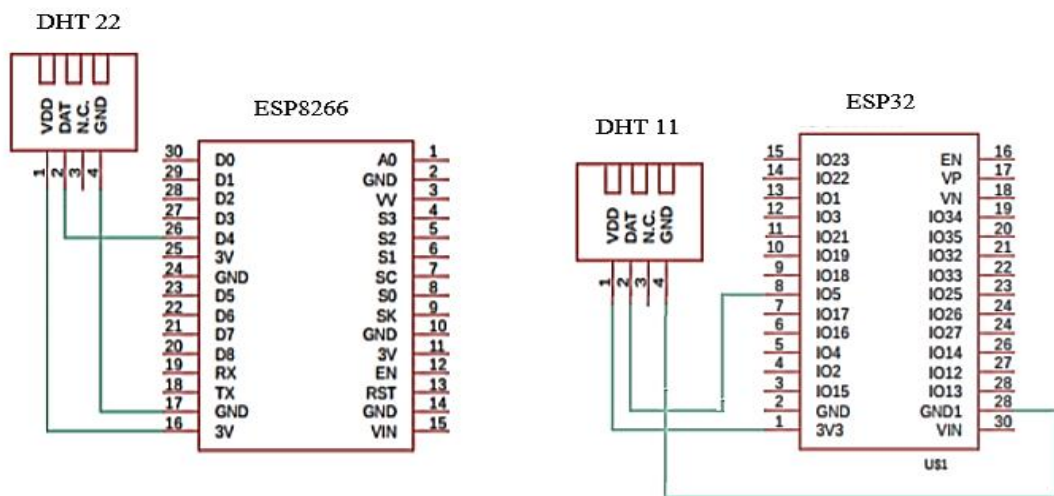

Figure 3. Circuit diagram

The Figure 3 demonstrate the schematic shown above is used to construct the hardware section for nodeMCU and DHT sensor modules based non-WiFi Mesh Network while at Figure 4 and Figure 5 shows the experimental set up of respective mention four hardware modules that communicating with each by sending data over a mesh network.

NodeMCU 1 module was integrated with:

- Input component: DHT-22 Sensor Module
- Output component: Computer

NodeMCU 2 module was integrated with:

- Input component: DHT-22 Sensor Module

- Output component: Computer
- NodeMCU 3 & 4 module was integrated with:
- Input component: DHT-11 Sensor Module
- Output component: Computer

All the nodes here were connected in a mutual distance as long it can discover the other nodes to evaluate the link performance under 2 scenarios and collect environmental data for monitoring objective. For the first scenario and second scenario in this experiment that are based on LoS condition for the fully-mesh and partially-mesh connected network of nodes.

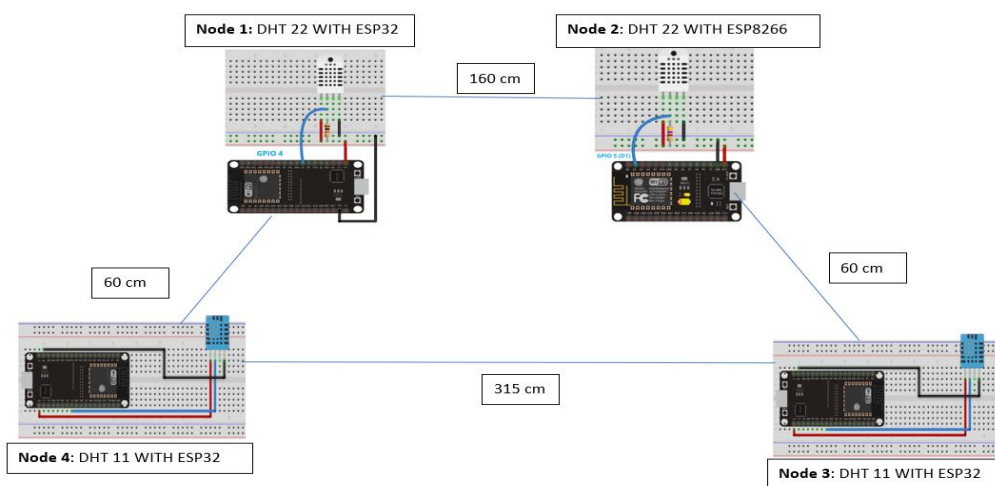

Figure 4. LoS Full-mesh Experiment setup without blockage for scenario 1

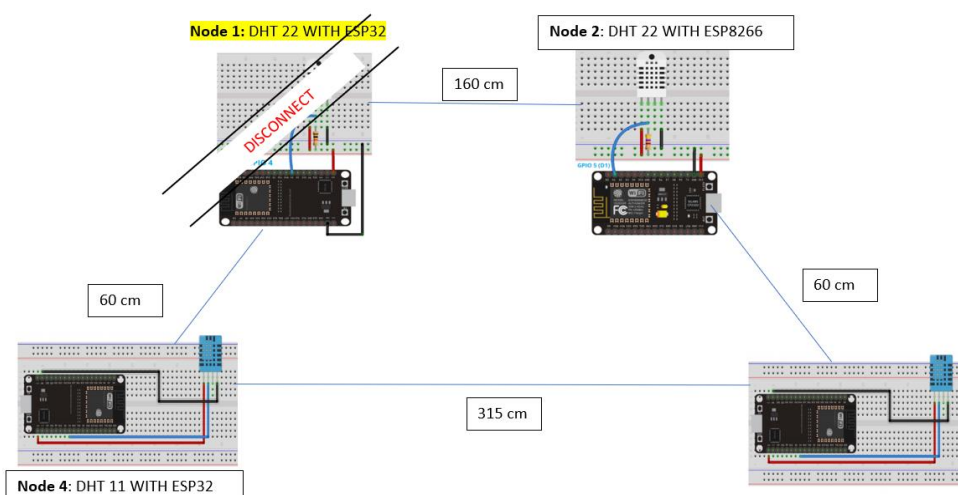

Figure 5. LoS Partial-mesh Experiment setup without blockage and with node 1 off for scenario 2

Meanwhile for Figure 6 and Figure 7 shows the third scenario and fourth scenario that are based on

nLoS condition for the fully-mesh and partially-mesh connected network of nodes.

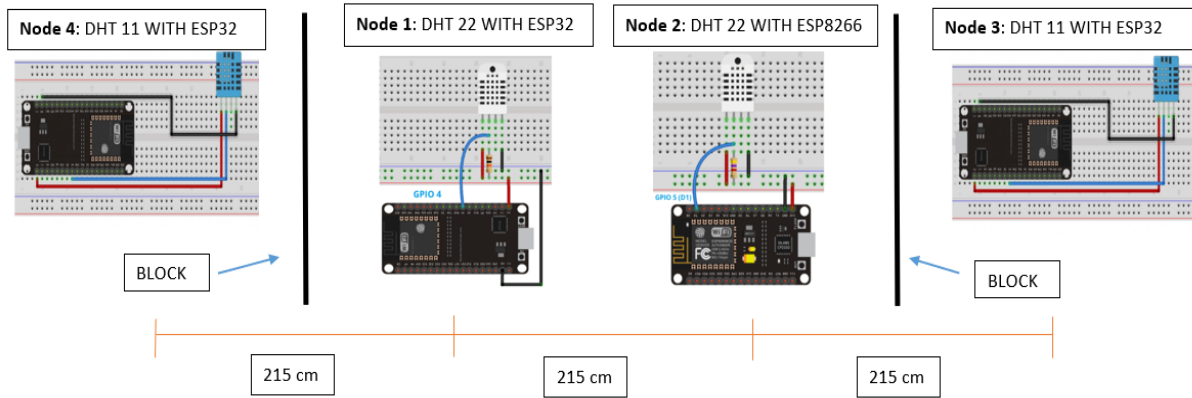

Figure 6. nLoS Full-mesh with blockage for scenarios 3

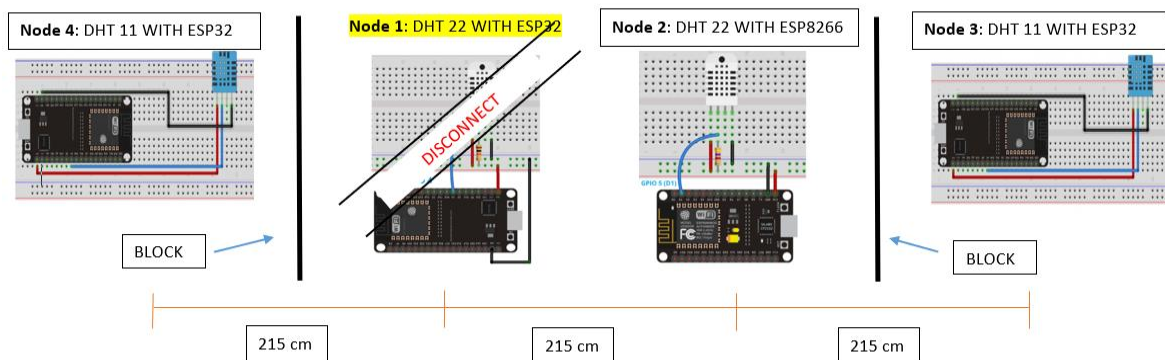

Figure 7. nLoS Partially-mesh with node 1 in off mode with blockage for scenario 4

Results:

The study here was carry out by a working prototype where the results obtained was tested for each input to ensure that it matched the intended output. Explicitly, it was using the serial port controller to get the outputs of each node in the mesh network. The serial port display used in this project was Arduino IDE. Each serial monitor

window had a different COM port address but the baud rate used by all the nodes was same i.e., 115200 bps. The serial monitor window would display the sensor reading at each node. Also, the timestamp features in the Arduino IDE serial monitor would tell us when the PC receives strings from Arduino Serial. The results are display as below:

```

COM3
13:34:34.525 -> New Connection, nodeId = 540953200
13:34:34.525 -> Changed connections
13:34:35.104 -> Changed connections
13:34:35.104 -> New Connection, nodeId = 3818269957
13:34:35.104 -> Adjusted time 773809020. Offset = 761369121
13:34:35.339 -> Adjusted time 774063027. Offset = 10902
13:34:35.572 -> Adjusted time 774263755. Offset = -11598
13:34:35.761 -> Adjusted time 774477627. Offset = 2187
13:34:37.294 -> Received from 3818269957 msg={"node":4,"temp":32.900001525878906,"hum":63.299999237060547}
13:34:37.294 -> Node: 4
13:34:37.294 -> Temperature: 32.90 C
13:34:37.294 -> Humidity: 63.30 %
13:34:38.498 -> Received from 540953200 msg={"node":2,"temp":31.399999618530273,"hum":69.699996948242188}
13:34:38.498 -> Node: 2
13:34:38.498 -> Temperature: 31.40 C
13:34:38.498 -> Humidity: 69.70 %
13:34:38.723 -> dhcp: send_nak>>udp_sendto result 0
13:34:38.946 -> Received from 3187118473 msg={"node":3,"temp":30.60000381469727,"hum":70}
13:34:38.946 -> Node: 3
13:34:38.946 -> Temperature: 30.60 C
13:34:38.946 -> Humidity: 70.00 %
13:34:39.526 -> dhcp: send_nak>>udp_sendto result 0
13:34:42.204 -> Received from 3818269957 msg={"node":4,"temp":32.900001525878906,"hum":63.400001525878906}
    
```

Figure 8. Readings from Node 1

```
COM6
13:36:15.987 -> Node: 4
13:36:15.987 -> Temperature: 1.00 C
13:36:15.987 -> Humidity: 1.00 %
13:36:20.511 -> Received from 3187118473 msg={"node":3,"temp":30.600000381469727,"hum":70}
13:36:20.511 -> Node: 3
13:36:20.511 -> Temperature: 30.60 C
13:36:20.558 -> Humidity: 70.00 %
13:36:20.558 -> Received from 682271221 msg={"node":1,"temp":30,"hum":72}
13:36:20.558 -> Node: 1
13:36:20.558 -> Temperature: 30.00 C
13:36:20.558 -> Humidity: 72.00 %
13:36:20.786 -> Received from 3818269957 msg={"node":4,"temp":32.900001525878906,"hum":63.299999237060547}
```

Figure 9. Readings from Node 2

```
COM3
13:37:10.542 -> Received from 540953200 msg={"node":2,"temp":31.700000762939453,"hum":68.699996948242188}
13:37:10.542 -> Node: 2
13:37:10.542 -> Temperature: 31.70 C
13:37:10.542 -> Humidity: 68.70 %
13:37:11.818 -> Received from 3818269957 msg={"node":4,"temp":32.900001525878906,"hum":63.400001525878906}
13:37:11.818 -> Node: 4
13:37:11.818 -> Temperature: 32.90 C
13:37:11.818 -> Humidity: 63.40 %
13:37:15.393 -> Received from 682271221 msg={"node":1,"temp":30,"hum":72}
13:37:15.442 -> Node: 1
13:37:15.442 -> Temperature: 30.00 C
13:37:15.442 -> Humidity: 72.00 %
13:37:15.491 -> Received from 540953200 msg={"node":2,"temp":31.700000762939453,"hum":68.699996948242188}
```

Figure 10. Readings from Node 3

```
COM3
13:36:34.185 -> Temperature: 31.70 C
13:36:34.232 -> Humidity: 68.90 %
13:36:39.082 -> Received from 682271221 msg={"node":1,"temp":30,"hum":72}
13:36:39.082 -> Node: 1
13:36:39.129 -> Temperature: 30.00 C
13:36:39.129 -> Humidity: 72.00 %
13:36:39.129 -> Received from 3187118473 msg={"node":3,"temp":30.600000381469727,"hum":70}
13:36:39.129 -> Node: 3
13:36:39.129 -> Temperature: 30.60 C
13:36:39.129 -> Humidity: 70.00 %
13:36:39.176 -> Received from 540953200 msg={"node":2,"temp":31.700000762939453,"hum":68.800003051757812}
13:36:39.223 -> Node: 2
13:36:39.223 -> Temperature: 31.70 C
13:36:39.223 -> Humidity: 68.80 %
13:36:44.098 -> Received from 682271221 msg={"node":1,"temp":30,"hum":72}
```

Figure 11. Readings from Node 4

Figure 8 until 11 depicts that mesh network topology successfully formed from Node 1 until Node 4 using LoS concept by knowing the MAC address of other boards to authenticate the transmitting the sensor data in the multi-hop fashion. The data is transmitted sequentially and the other boards would get the acknowledgement whether the sensor data is delivered or not. Figure 12 illustrates the delay distribution from the wireless mesh network for 100 readings under the mention condition and scenarios at the proposed work section. All scenarios show positively skewed

distribution. Both the LoS and nLoS conditions show almost similar delay distribution with median of ~2ms but with clear outliers outside the whiskers up to 9ms for nLoS. In third scenario, one of the nodes is turn off and the delay distribution show almost similar interquartile range with the two scenarios before. In last scenario, beside the Node 1 is turn-off but with some obstacle in between to make it like nLoS condition. The delay clearly shows long whiskers on positively skewed with larger interquartile range than before. It has median of 3ms with some outliers on 9ms. These indicate

that the delay dispersed and scattered more widely when in nLoS condition with one node turn off. This shows that the mesh network topology can

automatically make connections between each node and heal itself in the event of a disabled path.

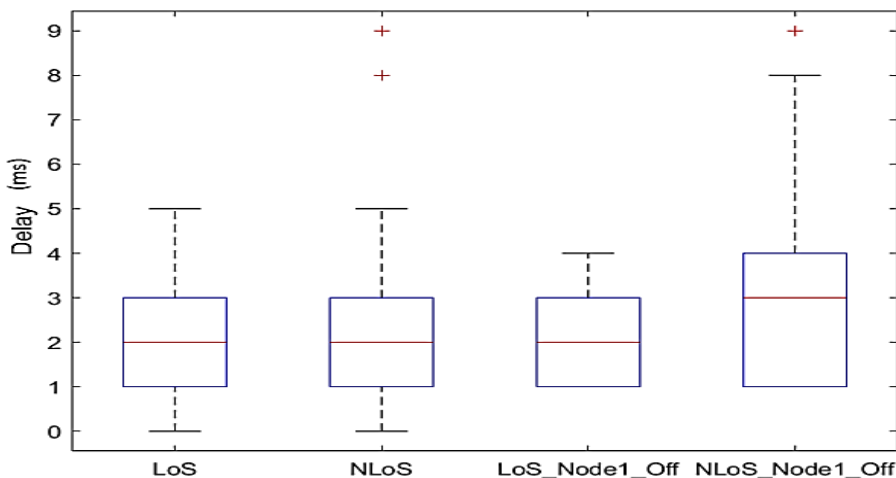

Figure 12. Delay distribution

From the mean formula in (1), the average time for LoS, nLoS, line-of-sight with node 1 in off mode (LoS_Node1_Off), and non-line-of-sight with

node 1 in off mode (nLoS_Node1_Off) were measured and calculated as shown in Table 2.

Table 2. Average delay time for LoS (Full-mesh), nLoS (Full-mesh), LoS_Node1_Off (partial-mesh) & nLoS_Node1_Off (partial-mesh)

Node	Average Delay Time (ms)			
	LoS	nLoS	LoS_Node1_Off	nLoS_Node1_Off
1	1.74	2.17	Disconnected	Disconnected
2	1.89	2.54	2.12	2.61
3	1.90	2.44	1.99	2.49
4	1.76	2.58	1.83	2.65
Average	1.82	2.43	1.98	2.58

According to the findings, the average delay time required in LoS is about 1.82ms, nLoS is 2.43ms, LoS_Node1_Off is 1.98ms and nLoS_Node1_Off is 2.58ms. It can be proved here that the mesh network can be formed more quickly in LoS condition either all nodes functioning and communicating to each other or when one node is off since it has shorter delay time when compared to nLoS condition. One of the reason is where the full-mesh topology in IoT sensor network can provides full redundancy and better performance with lowest value of time delay (1.82ms) which are without network facing blockage condition or any failure node occur. Under the same LoS condition, it can be observed for the partial-mesh connection the delay time would be higher due to lower hop count (2 hops) than the full-mesh topology (3 hops). Despite the higher delay time, the proposed work

here predicted would be useful when compared to the non-mesh connection which is point-to-point (p2p) communication. It would cause the loss of data collection for remote monitoring to occur by using p2p topology if any 1 node fail to operate.

Conclusion:

In this work, the mesh network of IoT sensor devices established without using the router or internet in between has better performance in both defined scenarios (connection of Full-mesh and partial-mesh) under LoS condition when compared to nLoS condition since a full open path without blockage is available for any node to transmit and receive data from other. Besides that, the nodes in mesh topology always find the best possible path to reroute data in case of failure which made it reliable in data handling and collection. As for the

future work, the work here will be integrated for further development in the soilless hydroponic system. It is because by combining agriculture with the mesh technology will allow and qualify a wide variety of new applications for highly efficient workflows in consumer and industrial technologies.

Acknowledgment:

The authors would like to express their deepest gratitude to Centre for Research and Innovation Management of Universiti Teknikal Malaysia Melaka (UTeM) under the Grant PJP/2020/FTKKE/PP/S01752

Authors' declaration:

- Conflicts of Interest: None.
- We hereby confirm that all the Figures and Tables in the manuscript are mine ours. Besides, the Figures and images, which are not mine ours, have been given the permission for republication attached with the manuscript.
- The author has signed an animal welfare statement.
- Ethical Clearance: The project was approved by the local ethical committee in University of Teknikal Malaysia Melaka.

Authors' contributions:

Nur Azzurin Afifie and Adam Wong Yoon Khang conceived of the presented idea. Nur Azzurin Afifie developed the theory and performed the computations. Abd Shukur bin Ja'afar and Ahmad Fairuz Bin Muhammad Amin verified the analytical methods. Jamil Abedalrahim Jamil Alsayaydehahmad encouraged Win Adiyansyah Indra to investigate the delay performance and supervised the findings of this work. Safarudin Gazali Herawan and Arnidza Binti Ramli helped to draft the manuscript. All authors discussed the results and contributed to the final manuscript.

References:

1. M. Ayaz, M. Ammad-Uddin, Z. Sharif, A. Mansour, E. H. M. Aggoune. Internet-of-Things (IoT)-based smart agriculture: Toward making the fields talk. *IEEE Access*, 2019;7:129551–129583.
2. R. Kashyap, M. Azman, J. G. Panicker. Ubiquitous Mesh: A Wireless Mesh Network for IoT Systems in Smart Homes and Smart Cities. 3rd IEEE International Conference on Electrical, Computer and Communication Technologies, ICECCT. 2019;2019(Article ID 19065315):1–3.
3. Q. Wang, H. Wang, M. He, H. Chen, X. Zhang. Optimization Deployment of WL-MESH Network with Base-station in Nature Environment. 9th IEEE Int. Conf. Cyber Technol. Autom. Control Intell. Syst. CYBER. 2020; 2020(Article ID 19533195):1–3.
4. Y. S. Song, S. K. Lee, K. W. Min. Analysis of Smart Street Lighting Mesh Network Using I2I Communication Technology. Int. Conf. ICT Converg., 2020; 2020(Article ID 20300170):981–983.
5. S. Pandi, S. Wunderlich, F. H. P. Fitzek. Reliable low latency wireless mesh networks - From Myth to reality. CNC 2018 - 2018 15th IEEE Annu. Consum. Commun. Netw. Conf. 2018;2018(Article ID 17649756):1–2.
6. E. Di Pascale, I. Macaluso, A. Nag, M. Kelly, and L. Doyle. The Network As a Computer: A Framework for Distributed Computing over IoT Mesh Networks. *IEEE Internet Things J.* 2018;5(3):2107–2119.
7. W. Li and H. Bai. A new wireless mesh network based on network coding technology. Proc. - 2018 Int. Conf. Sens. Networks Signal Process. 2019;2019(Article ID 18421355):35–39.
8. R. Rotsching, D. Tudose. Versatile Wireless Mesh Networking Platform. Proc. - RoEduNet IEEE Int. Conf. 2019;2019(Article ID 19187001):1–5.
9. M. Filho, M. Ribeiro, I. Silva, A. Santos, C. Oliveira, R. Braga. Performance Issues in a Low Cost Multi-Channel Multi-Interface Wireless Mesh Network. Proc. - IEEE Symp. Comput. Commun. 2018;2018(Article ID 18268899):00792-00795.
10. S. Lucero. IoT platforms: enabling the Internet of Things. *IHS Technol.* 2017; 1–19.
11. S. M. Darroudi, C. Gomez. Modeling the Connectivity of Data-Channel-Based Bluetooth Low Energy Mesh Networks. *IEEE Commun. Lett.* 2018;22(10):2124–2127.
12. H. C. Lee, K. H. Ke. Monitoring of Large-Area IoT Sensors Using a LoRa Wireless Mesh Network System: Design and Evaluation. *IEEE Trans. Instrum. Meas.* 2018;67(9):2177–2187.
13. M. R. Yamarthy, M. V. Subramanyam, K. S. Prasad. An efficient resource management algorithm for mobility management in wireless mesh networks. Int. Conf. Energy, Commun. Data Anal. Soft Comput. ICECDS, 2018;2018(Article ID 17859542):3249–3255.
14. H. Fujinaka, T. Ohta, and Y. Kakuda. Evacuation Route Guidance Scheme for Building Evacuation Using Wireless Mesh Network Systems. Proc. - 2020 8th Int. Symp. Comput. Netw. Work. CANDARW, 2021;2021(Article ID 20489482):8–13.
15. A. Hirata, T. Oda, N. Saito, K. Kanahara, M. Hirota, and K. Katayama. Approach of a Solution Construction Method for Mesh Router Placement Optimization Problem. 2020 IEEE 9th Glob. Conf. Consum. Electron. GCCE. 2020;2020(Article ID 20300625):467–468.
16. R. Muhendra, A. Rinaldi, M. Budiman, Khairurrijal. Development of WiFi Mesh Infrastructure for Internet of Things Applications. *Procedia Eng.* 2017;170:332–337.
17. Y. Chai, W. Shi. Access-enhanced hybrid routing protocol for hybrid wireless mesh network. 2017 9th IEEE Int. Conf. Commun. Softw. Networks, ICCSN. 2017;2017(Article ID17450898):138–141.

18.J. Liu, P. Wang, J. Lin. Real time scheduling for wireless mesh networked control systems. 9th IEEE Int. Conf. Commun. Softw. Networks, ICCSN, 2017;2017(Article ID 17450710):382–386.

19.M. S. K. M. Ms. Manvi. Implementing Wireless Mesh Network Topology between Multiple Wi-Fi Powered Nodes for IoT Systems. International Research Journal of Engineering and Technology. 2020;7(10):1242–1244.

طريقة تقييم بروتوكول الشبكة على ESP32 و ESP8266

نور عزورين عفيفي¹ آدم وونغ يون خانغ^{1*} عبد شكر بن جعفر² أحمد فيروز بن محمد أمين¹
جميل عبد الرحيم جميل السيايدة¹ وين اديانسيه اندرا¹ سفر الدين غزالي حراوان³ أرنيزة بنت رملي⁴

¹مجموعة أبحاث النطاق العريض والشبكات (BBNET)، مركز أبحاث الاتصالات السلكية واللاسلكية والابتكار، كلية الهندسة الكهربائية والإلكترونية (FTKEE)، جامعة ماليزيا التقنية (UTeM)، ملقا، ماليزيا
²مركز أبحاث الاتصالات السلكية واللاسلكية والابتكار (CeTRI)، كلية الهندسة الإلكترونية والحاسوب (FKEKK)، جامعة ماليزيا التقنية (UTeM)، ملقا، ماليزيا
³قسم الهندسة الصناعية، كلية الهندسة، جامعة بينا نوسانتارا، جاكارتا، إندونيسيا
⁴مجموعة أبحاث الاتصالات لايت ويف (LCRG)، جامعة ماليزيا للتكنولوجيا، جوهور باهرو، ماليزيا

الخلاصة:

بعد إنترنت الأشياء (IoT) أحد أحدث الأمور في كل من الصناعة والأوساط الأكاديمية في عالم هندسة الاتصالات. من ناحية أخرى، يمكن للشبكات المعشقة اللاسلكية، وهي طوبولوجيا الشبكة التي ظلت موضع نقاش منذ عقود ولم يتم استخدامها على نطاق واسع، أن تحدث تحولاً عندما تظهر في الشبكة في عالم إنترنت الأشياء في الوقت الحاضر. شبكة Mesh IoT هي بنية شبكة محلية تتعاون فيها الأجهزة المرتبطة وتوجه البيانات باستخدام بروتوكول محدد. عادةً تتبادل أجهزة إنترنت الأشياء IoT بيانات المستشعر عن طريق الاتصال ببوابة IoT. ومع ذلك، هناك حدود معينة إذا كان الأمر يتعلق بعدد كبير من أجهزة الاستشعار (sensor) فهذا يعقد عملية تحليل البيانات التي ينبغي تلقيها. الهدف من البحث هنا تنفيذ شبكة شبكية ذاتية التكوين في أجهزة استشعار IoT لتحسين جودة جمع البيانات المستقلة. البحث الذي تم إجراؤه في هذه الورقة هو بناء شبكة شبكية باستخدام NodeMCU ESP 8266 و NodeMCU ESP 32 مع نوعين من أجهزة الاستشعار، DHT 11 و DHT 22. ومن ثم، فقد تم تقييم العمل هنا على مقياس أداء التأخير في خط البصر (LoS) و (Non-Line-of-Sight (nLoS) بناءً على اتصال الشبكة المختلفة. تعطي النتائج وقت تأخير أقصر في حالة خط البصر لجميع العقد المتصلة وكذلك عندما تفشل أي عقدة في العمل في الشبكة المعشقة مقارنة بحالة nLoS. توضح هذا البحث أن أجهزة استشعار إنترنت الأشياء التي تتكون منها الشبكة المعشقة ضرورية للاستفادة من أداء اتصال الرابط لجمع البيانات من أجل استخدامها في التطبيقات القائمة على إنترنت الأشياء مثل نظام الإخصاب. من المؤكد أنه سيحدث فرقاً في الصناعة بمجرد نشره على نطاق واسع في عالم إنترنت الأشياء وسيجعل إنترنت الأشياء في متناول جمهور أوسع.

الكلمات المفتاحية: NodeMCU، nLoS، Mesh Network، LoS، IoT.