

Design and Mathematical Analysis of Reconfigurable Frequency and Function Between Feeding Network and SPDT Switch

N. Edward¹, N. A. Shairi¹ and Z. Zakaria¹

¹ *Microwave Research Group (MRG), Centre for Telecommunication Research & Innovation (CeTRI), Fakulti Kejuruteraan Elektronik dan Kejuruteraan Komputer (FKEKK), Universiti Teknikal Malaysia Melaka (UTeM), Hang Tuah Jaya, 76100, Durian Tunggal, Melaka, Malaysia.*

Abstract

This paper proposes a reconfigurable frequency and function between the feeding network and Single Pole Double Throw (SPDT) switch in a single design. In order to realize a reconfigurable function and frequency for the feeding network and SPDT switch, a Positive Intrinsic Negative (PIN) diode is used. The feeding network consists of two modified Wilkinson power dividers (WPDs), which operates at 2.5 GHz and 3.5 GHz. For the SPDT switch function, PIN diodes are added in the input and output ports of the feeding network to turn on or off the output port. Then, shorted stub is placed into the output port for matching when the feeding network function is changed to a SPDT switch. The proposed design realized a reconfigurable function that can either operate as a feeding network or SPDT switch by using PIN diodes and can be used for antenna array or power amplifiers applications. The proposed design shows good S-parameters performance at 2.5 GHz and 3.5 GHz based on simulation results acquired from a software of the Advanced Design System (ADS). The measurement results, however, indicate a frequency shift. Although the results of measurements were correlated to simulations, the resonant frequency was shifted due to the parasitic reactance of the PIN diode.

Keywords: Feeding network, PIN diode, Reconfigurable, Shorted stub, SPDT Switch

I. INTRODUCTION

Reconfigurable mobile terminals have recently become a trend. Many reconfigurable antennas were, therefore, validated and tested in practice [1]-[3]. Advanced feeding networks are essential to helpfully achieve systems such as smart antennas and phase-array antennas [4]-[6]. One of the main parts in a different type of microwave circuit is the Wilkinson Power Division (WPD) that has commonly used for antenna power division and combination feeding networks [6]-[8]. Two quarter-wavelength transmission lines are utilized by the conventional Wilkinson power divider and it operates only at a certain frequency [9].

There are few methods that can be done to achieve the reconfigurable function of the feeding network, including varactor [10]-[13]. However, the design of WPD will be more complicated with the implementation of varactors. In [14], electrification of the top and bottom surface electrode of the liquid crystal (LC) with an alteration of the voltage values are

the methods used in designing a reconfigurable feeding network. Nevertheless, this design would make the fabrication process more complex. Besides, the reconfigurable feeding network capabilities can also be obtained by utilizing PIN diode [15], [16]. In our previous research works, PIN diodes were used in the reconfigurable filter of SPDT switch [17], multiband isolation of SPDT switch [18], and filter integrated SPDT switch [19]. Therefore, the SPDT switch function can also be achieved using PIN diodes in the feeding network design. In designing a SPDT switch, the PIN diode is the main component. The feeding network function can be switched into a power divider or SPDT switch using PIN diodes in a single design [20]. However, the size of the proposed design is large and hard to fabricate.

In this article, a reconfigurable frequency and function between the feeding network and SPDT switch is presented at 2.5 GHz and 3.5 GHz operating frequencies. The feeding network consists of two modified WPDs that can be individually reconfigured by PIN diode switches for its length. The operating frequency of the proposed design can be varied between two frequency bands by varying the bias voltages of these PIN diodes. In comparison to [15], the proposed design can also switch its function between a power divider and a SPDT switch. In addition, a new feature is presented in the proposed design, which is multiband, compared with [20] for both functions. Nevertheless, when the function switches to a SPDT switch, a mismatch is observed. Thus, two shorted stubs for the 2.5 GHz and 3.5 GHz SPDT switches are introduced at the output ports. In this paper, the reconfigurable feeding network is designed, simulated, and investigated.

II. RECONFIGURABLE FREQUENCY AND FUNCTION BETWEEN FEEDING NETWORK AND SPDT SWITCH

Figure 1 shows the proposed design of the reconfigurable feeding network; and the position of the PIN diodes (D1-D16). A parametric study is done to make the design narrowband. In this proposed design, a narrowband is required to allow only signals at 2.5 GHz or 3.5 GHz. Since this proposed design is required to be operated either at 2.5 GHz or 3.5 GHz, there are two modified WPDs are designed at different frequencies. Both designs are then combined using the PIN diode to make it a single design. In this design, PIN diodes are used to reconfigure the feeding network's transmission line length. Meanwhile, one of the output ports will be turn off using PIN diodes for the

SPDT switch function. In this proposed design, PIN diodes play a vital role in ensuring that this design are able to reconfigure its functionality and operating frequencies at the same time.

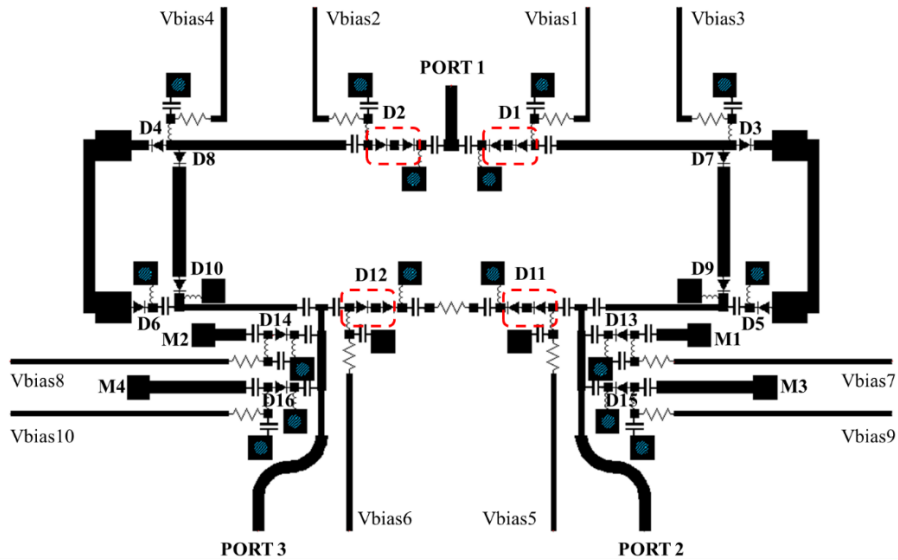

Fig. 1. The diagram of the reconfigurable frequency and function between the feeding network and SPDT switch

From Figure 1, when D7, D8, D9, D10, D13, D14, D15, and D16 are turned off, the feeding network operates at a frequency of 2.5 GHz. While PIN diodes, D3, D4, D5, D6, D13, D14, D15, and D16 are turned off, the feeding network operates at a frequency of 3.5 GHz. Figure 2 (a) and (b) show the circuit configuration when the feeding network operates at frequency of 2.5 GHz and 3.5 GHz, respectively.

Based on Figure 1, in order to turn off Port 3, PIN diodes, D2, D11, and D12, will be turned off to achieve a SPDT switch function. However, there will be a mismatch when one of the output ports is turned off. This can be compensated by placing

stubs at the output ports. Two stubs are placed at each of the output ports for matching SPDT switch at 2.5 GHz and 3.5 GHz. These matching stubs are controlled by the PIN diodes, D13 to D16, upon the state of the proposed design itself. The SPDT switch function is also reconfigurable in terms of its operating frequency. It can operate either at 2.5 GHz or 3.5 GHz. Figure 2 (c) and (d) show the circuit configuration for the SPDT switch at 2.5 GHz and 3.5 GHz, respectively. The summary of the process during power divider and SPDT switch function at 2.5 GHz and 3.5 GHz of the proposed reconfigurable feeding network are represented in Table 1.

Table 1. The process summarization of the reconfigurable frequency and function between the feeding network and SPDT switch

	Feeding Network (Modified WPD)		SPDT Switch	
	2.5 GHz	3.5 GHz	2.5 GHz (PORT 2 ON)	3.5 GHz (PORT 2 ON)
+5 Volt	Vbias1, 2, 3, 4, 5, & 6	Vbias1, 2, 5, & 6	Vbias1, 3, & 7	Vbias1 & 9
-5 Volt / 0 Volt	Vbias7, 8, 9, & 10	Vbias3, 4, 7, 8, 9, & 10	Vbias2, 4, 5, 6, 8, 9, 10	Vbias2, 3, 4, 5, 6, 7, 8, & 10
ON State	D1, 2, 3, 4, 5, 6, 11, & 12	D1, 2, 7, 8, 9, 10, 11, 12,	D1, 3, 5, & 13	D1, 7, 9, & 15
OFF State	D7, 8, 9, 10, 13, 14, 15, & 16	D3, 4, 5, 6, 13, 14, 15, & 16	D2, 4, 6, 7, 8, 9, 10, 11, 12, 14, 15, & 16	D2, 3, 4, 5, 6, 8, 10, 11, 12, 13, 14, & 16

The circuit configurations of the proposed feeding network are simulated to obtain the S-parameters results at 2.5 GHz and 3.5 GHz, respectively. The following Figure 3 shows the result for S11, S21, S31, and S23. Based on Figure 3 (a) and (b), the return loss for both frequencies of power divider function is greater than 15 dB, the insertion loss is less than 4.2 dB, and

the isolation is less than -15 dB. Meanwhile, Figure 3 (c) and (d) show the return loss, S11, insertion loss, S21, and isolation, S23 and S31, for both frequencies at 2.5 GHz and 3.5 GHz for SPDT switch function, respectively. It can be seen that both frequencies have return loss less than -15 dB, insertion loss less than -2 dB, and isolation less than -30 dB for S23 and S13.

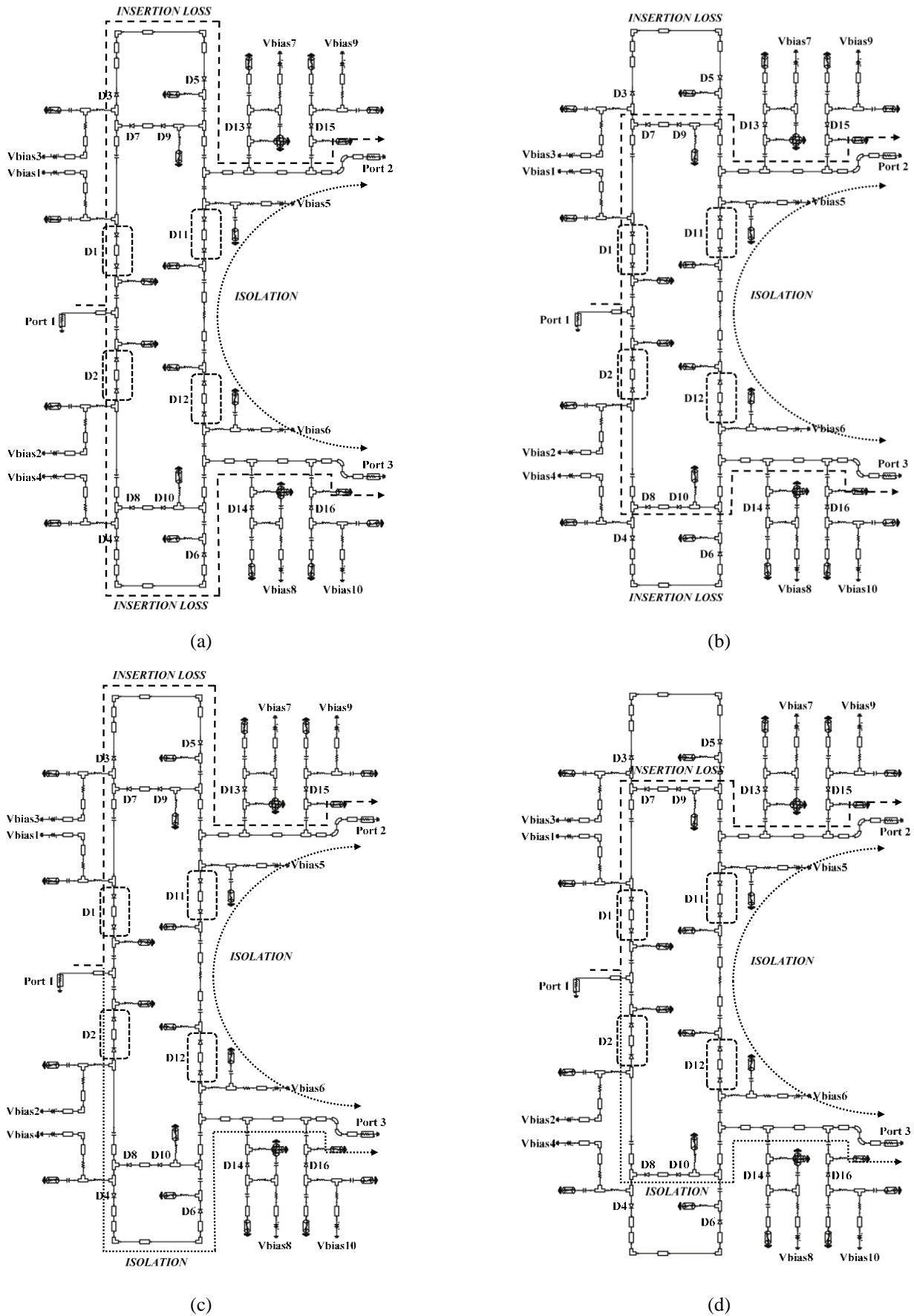

Fig. 2. The circuit configuration of the reconfigurable feeding network; (a) Power divider at 2.5 GHz; (b) Power divider at 3.5 GHz; (c) SPDT switch at 2.5 GHz; (d) SPDT switch at 3.5 GHz

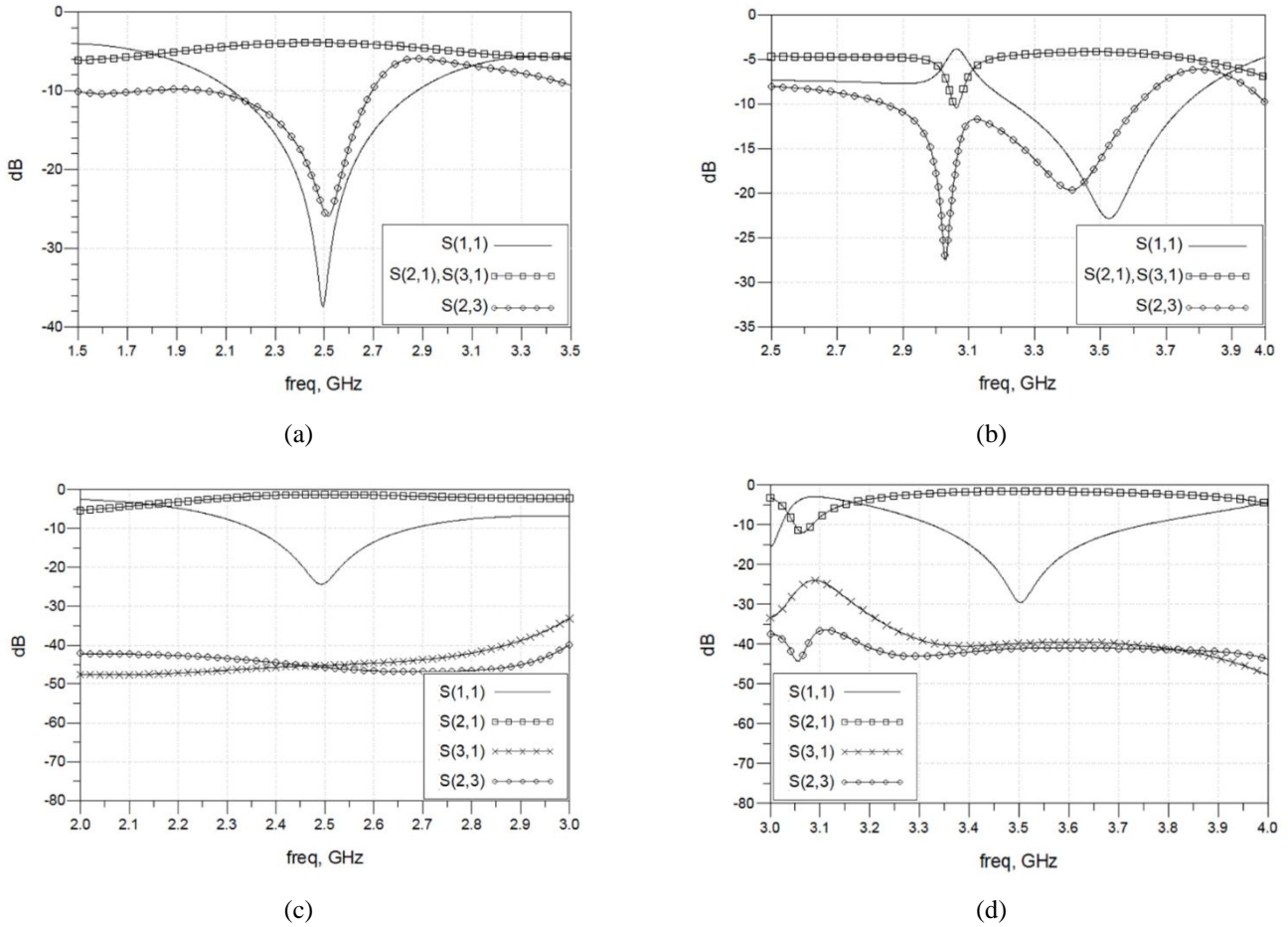

Fig. 3. The simulation result of the reconfigurable feeding network; (a) Power divider at 2.5 GHz; (b) Power divider at 3.5 GHz; (c) SPDT switch at 2.5 GHz; (d) SPDT switch at 3.5 GHz

III. MATHEMATICAL ANALYSIS OF RECONFIGURABLE FEEDING NETWORK AS A SPDT SWITCH

III.I The Insertion Loss of Reconfigurable Feeding Network as a SPDT Switch

This is a simple analysis and discussion of the reconfigurable feeding network insertion loss as a SPDT switch. In the reconfigurable feeding network as a SPDT switch of 2.5 GHz, an ABCD matrix of the two-port network was analyzed by considering an ON state PIN diodes of Port 2. Furthermore, the series PIN diode (D15), which controls the matching stub, M3, was ON too. Therefore, the ABCD matrix could be as follows:

$$[T] = [T_{DT}][T_{M3}] = \begin{bmatrix} A & B \\ C & D \end{bmatrix} \quad (1)$$

where,

$$[T_{DT}] = \begin{bmatrix} 1 & 4R_f + 4j\omega L_i \\ 0 & 1 \end{bmatrix} \quad (2)$$

$$[T_{M3}] = \begin{bmatrix} 1 & 0 \\ \frac{1}{jZ_s \tan(x)} & 1 \end{bmatrix} \quad (3)$$

Substituting (2) and (3) into (1) gives,

$$[T] = \begin{bmatrix} 1 & 4R_f + 4j\omega L_i \\ 0 & 1 \end{bmatrix} \begin{bmatrix} 1 & 0 \\ \frac{1}{jZ_s \tan(x)} & 1 \end{bmatrix} \quad (4)$$

$$[T] = \begin{bmatrix} 1 + \frac{\cos(x)(4R_f + 4j\omega L_i)}{jZ_s \sin(x)} & 4R_f + 4j\omega L_i \\ \frac{\cos(x)}{jZ_s \sin(x)} & 1 \end{bmatrix} \quad (5)$$

where T_{DT} is the transfer ABCD matrix of total series PIN diodes in ON state, R_f is the PIN diode resistance during forward bias, L_i is the inductance of PIN diode [9], T_{M3} is the transfer function ABCD matrix of the matching stub [21]. Converting the ABCD matrix of (1) to S-parameter, S_{21} was expressed as

$$S_{21} = \frac{2}{\left(A + \frac{B}{Z_0} + C Z_0 + D \right)} \quad (6)$$

By substituting the result of (5) into (6),

$$S_{21} = \frac{2}{2 + \frac{4R_f + 4j\omega L_i}{jZ_s \tan(x)} + \frac{4R_f + 4j\omega L_i}{Z_0} + \frac{\cos(x) Z_0}{jZ_s \sin(x)}} \quad (7)$$

Consider $x = \frac{\pi}{2}$ (a quarter wavelength), $Z_s = 1$, $R_f + j\omega L_i \approx 0$, and a normalized characteristic of impedance, $Z_0 = 1$. Hence, the S_{21} of became

$$S_{21} \approx 1,$$

or in decibel

$$|S_{21}|^2 dB = 20 \log(1) = 0 dB \quad (8)$$

Theoretically, it is clearly observed that zero insertion loss, S_{21} , can be achieved. From (7), an ideal insertion loss was produced. This insertion loss characteristic was used in reconfigurable feeding network as a SPDT switch to produce low insertion loss.

III.II The Isolation of Reconfigurable Feeding Network as a SPDT Switch

This is a simple mathematical analysis and discussion of isolation of reconfigurable feeding network as a SPDT switch. The ABCD matrix of the two-port network was analyzed by considering an OFF state PIN diodes of Port 3 in reconfigurable feeding network as a SPDT switch at 2.5 GHz. Thus, the ABCD matrix could be as follows:

$$[T] = [T_{DT}] = \begin{bmatrix} A & B \\ C & D \end{bmatrix} \quad (9)$$

$$[T] = [T_{DT}] = \begin{bmatrix} 1 & 4R_r + 4j\omega L_i - \frac{4j}{\omega C_j} \\ 0 & 1 \end{bmatrix} \quad (10)$$

where R_r is the resistance of PIN diode during reverse bias, L_i is the inductance of PIN diode and C_j is the junction capacitance. Converting the ABCD matrix of (9) to S-parameter, S_{31} was expressed as

$$S_{31} = \frac{2}{\left(A + \frac{B}{Z_0} + C Z_0 + D \right)} \quad (11)$$

By substituting the result of (10) into (11),

$$S_{31} = \frac{2}{2 + \frac{4R_r + 4j\omega L_i - \frac{4j}{\omega C_j}}{Z_0}} \quad (12)$$

Consider $C_j \approx 0$. $R_r + j\omega L_i$ can be ignored since it is usually small relative to the series reactance due to the junction capacitance and a normalized characteristic of impedance, $Z_0 = 1$. Hence, the S_{31} became

$$S_{31} \approx 0,$$

or in decibel

$$|S_{31}|^2 dB = 20 \log(0) = \infty dB \quad (13)$$

Theoretically, it was clearly observed that if $C_j \approx 0$, infinite isolation, S_{31} , could be achieved. From (12), ideal infinite isolation was produced. In reconfigurable feeding network as a SPDT switch, high isolation is produced by using this attenuation characteristic.

IV. SIMULATION AND MEASUREMENT RESULTS OF THE RECONFIGURABLE FREQUENCY AND FUNCTION BETWEEN FEEDING NETWORK AND SPDT SWITCH

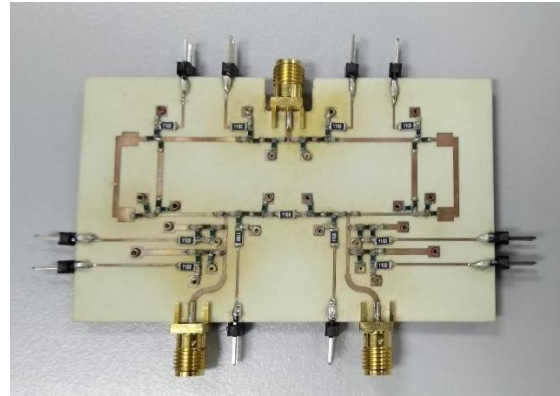

Fig. 4. The prototype of the reconfigurable frequency and function between the feeding network and SPDT switch

The proposed design was fabricated in the laboratory using substrate Rogers RO4350. Figure 4 is the fabricated reconfigurable feeding network. The total layout area is 48.1 mm × 80.9 mm. The proposed design was fabricated to validate the simulation results after designing with ADS software. By using a vector network analyzer, the prototype from Figure 4 was measured in terms of its S-parameters, return loss, insertion loss, and isolation. Table 2 show the comparison between the measurement results and simulation results, S_{11} , S_{21} , S_{31} , and S_{23} for reconfigurable feeding network operates as a power divider and a SPDT switch at 2.5 GHz and 3.5 GHz, respectively.

Table 2. The simulation and measurement results of the reconfigurable modified WPD integrated SPDT switch

Function	Feeding Network (Modified WPD)				SPDT Switch			
	2.5 GHz	1.86 GHz	3.5 GHz	3.52 GHz	2.5 GHz	2.4 GHz	3.5 GHz	3.25 GHz
Frequency	Sim	Meas	Sim	Meas	Sim	Meas	Sim	Meas
S11	-36.811 dB	-9.536 dB	-22.074 dB	-12.313 dB	-24.059 dB	-22.039 dB	-29.482 dB	-17.873 dB
S21	-3.949 dB	-5.218 ± 0.114 dB	-4.178 dB	-11.363 ± 0.14 dB	-1.267 dB	-2.091 dB	-1.569 dB	-3.43 dB
S31					-45.173 dB	-47.543 dB	-39.820 dB	-46.496 dB
S23	-25.433 dB	-13.632 dB	-16.196 dB	-9.521 dB	-45.762 dB	-45.243 dB	-41.084 dB	-41.215 dB

Based on Figure 5 (a) and (b), the frequency for reconfigurable feeding network operates as a power divider at 2.5 GHz was shifted around 600 MHz compared to simulation results. The measurement result S11 for modified WPD at a resonant frequency of 1.86 GHz was -9.536 dB, S23 was -13.632 dB, S12, and S13 was -5.218 ± 0.114 dB. Meanwhile, based on Figure 5 (c) and (d), the frequency was shifted about 20 MHz for reconfigurable feeding network operates as a power divider at 3.5 GHz. The measurement result of modified WPD's return loss at a resonant frequency of 3.52 GHz was 12.313 dB, S23 was -9.521 dB, S12, and S13 was -11.363 ± 0.14 dB. When the reconfigurable feeding network operates as a SPDT switch at 2.5 GHz, the resonant frequency was shifted to around 100 MHz. The measurement result S11 at resonant frequency 2.4 GHz was -22.039 dB, S21 was -2.091 dB, S31 was -47.543 dB,

and S23 was -45.243 dB based on Figure 5 (e) and (f). Moreover, the frequency for reconfigurable feeding network operates as a SPDT switch at 3.5 GHz was shifted around 250 MHz compared to the simulated results. Based on Figure 5 (g) and (h), the measurement results of the SPDT switch's return loss was 17.873 dB, S21 was -3.43 dB, S31 was -46.496 dB, and S23 was -41.215 dB. The shifting frequency is due to the parasitic reactance of the PIN diode (inductance or capacitance). Diodes can be replaced by Microelectromechanical Systems (MEMS) devices in future work. Furthermore, the measurement results for the feeding network function between S21 and S31 showed slightly different for its insertion loss, which indicates the prototype was almost symmetrically fabricated and soldered component.

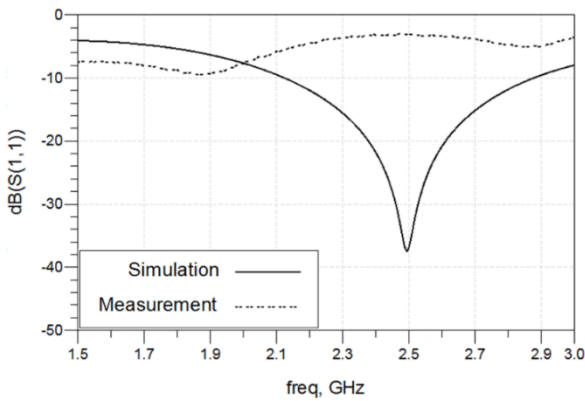

(a)

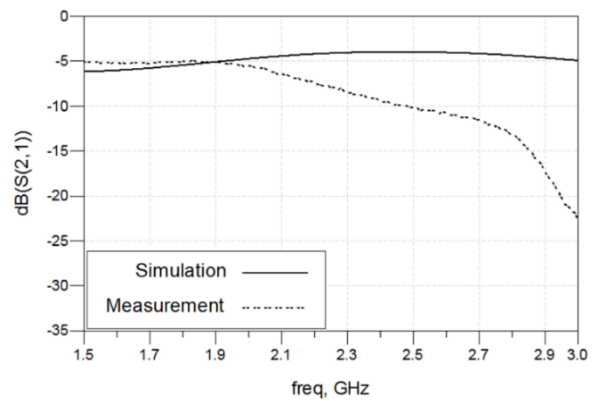

(b)

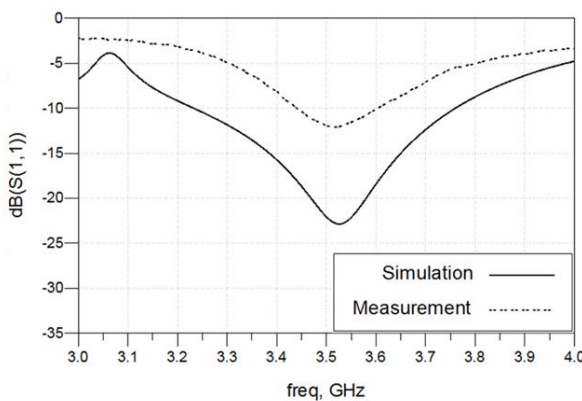

(c)

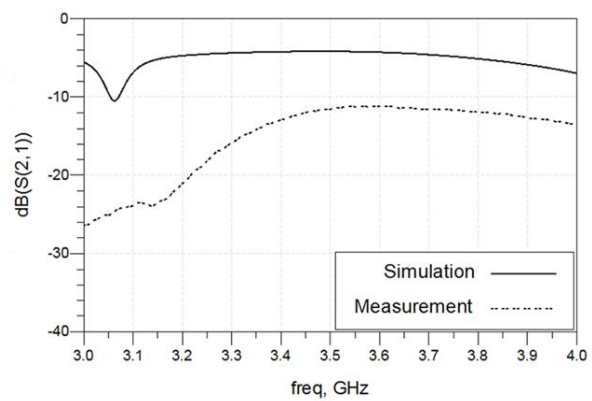

(d)

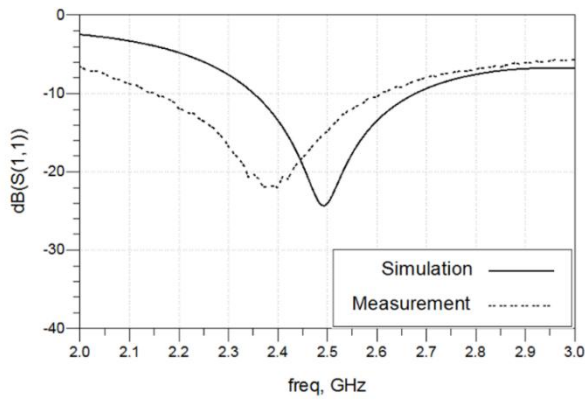

(e)

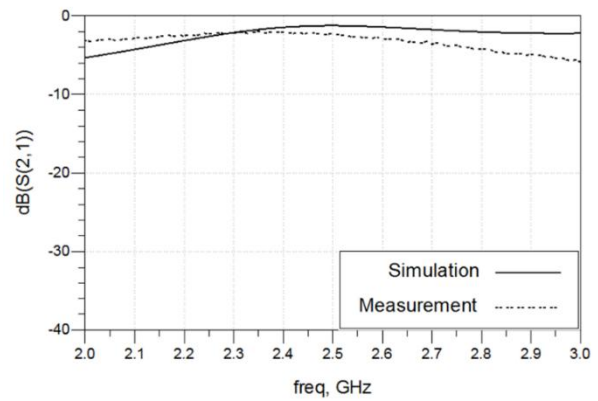

(f)

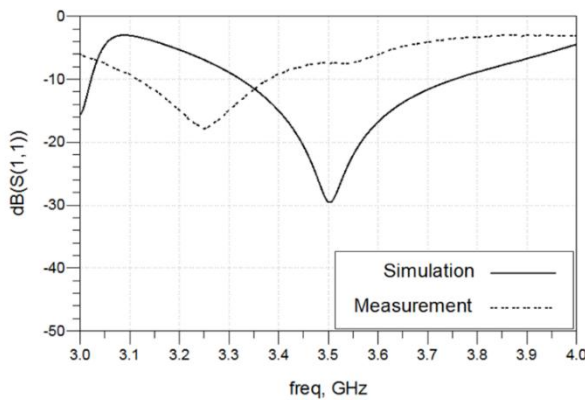

(g)

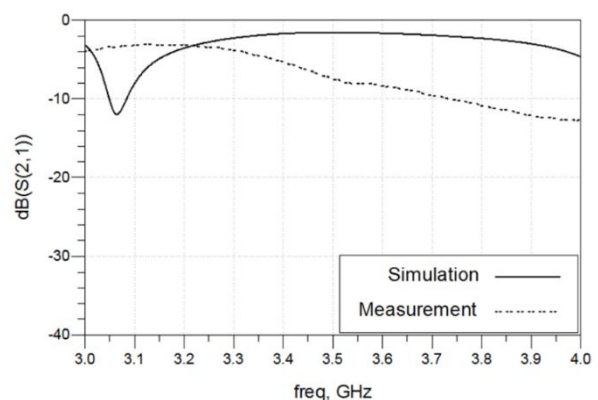

(h)

Fig. 5. Simulation and measurement results of reconfigurable feeding network; (a) S11 and (b) S21 of power divider at 2.5 GHz; (c) S11 and (d) S21 of power divider at 3.5 GHz; (e) S11 and (f) S21 of SPDT switch at 2.5 GHz; (g) S11 and (h) S21 of SPDT switch at 3.5 GHz

V. CONCLUSION

The design of the reconfigurable frequency and function between feeding network and SPDT switch has been successfully designed, simulated, measured, and investigated. The length of the transmission line is reconfigured using PIN diodes and combined the two Wilkinson power dividers at different operating frequencies, 2.5 GHz and 3.5 GHz. The conventional WPD has a wideband frequency, but it requires a narrowband frequency at 2.5 GHz or 3.5 GHz for this feeding network design. The simulation results showed good agreement for both functions and frequencies with return loss more than 15 dB, insertion loss less than 4.2 dB, and isolation less than -10 dB. Even though there was a frequency shifted in measurement, the measurement results still correlated with the simulation results.

ACKNOWLEDGEMENT

We are grateful to UTeM Zamalah Scheme for their encouragement and help in supporting financially to complete this research work.

REFERENCES

- [1] Ibrahim A. M., Ibrahim I. M., Shairi N. A., Compact V-Shaped MIMO Antenna for LTE and 5G Applications, *Przełąd Elektrotechniczny*, 2020;96(11):84-89.
- [2] Xu Y., Liang Y., Zhou H., Small-size reconfigurable antenna for WWAN/LTE/GNSS smartphone applications, *IET Microw., Antennas & Propag.*, 2017; 11(6):923-928.
- [3] Chen Q., Li J., Yang G., Cao B., Zhang Z., A Polarization-Reconfigurable High-Gain Microstrip Antenna, *IEEE Trans. on Antennas and Propag.*, 2019;67(5):3461-3466.
- [4] Wi S., Zhang Y. P., Kim H., Oh I., Yook J., Integration of Antenna and Feeding Network for Compact UWB Transceiver Package, *IEEE Trans. on Components, Packaging and Manufacturing Technol.*, 2011;1(1):111-118.
- [5] Slomian I., Gruszczynski S., Rydosz A., Wincza K., Dual-Circular Polarized Antenna Lattice with Odd Number of Radiating Elements and Integrated Feeding Network, 2018 IEEE International Symposium on

- Antennas and Propagation & USNC/URSI National Radio Science Meeting, Boston, MA, 2018:1615-1616.
- [6] Robert J., Minard P., Louzir A., Feeding Concept for a Multisector Antenna System, 2008 38th European Microwave Conference, Amsterdam, 2008:1102-1105.
- [7] Hammad H. F., UWB Modified Elliptical Antipodal Vivaldi antenna array fed with four stage Wilkinson Power Divider, 2019 IEEE International Symposium on Antennas and Propagation and USNC-URSI Radio Science Meeting, Atlanta, GA, USA, 2019:463-464.
- [8] Santiko A. B., Susanti N. D., Taufiqurrachman T., Compact Structure and Low Losses for Wilkinson Power Divider at 9400MHz Frequency for X-Band Antenna System, TELKOMNIKA, 2017;15(1):143-149.
- [9] Pozar D., Microwave Engineering, 3rd ed. Hoboken, New Jersey: John Wiley & Sons Inc, 2005.
- [10] Zhang T., Che W., A Compact Tunable Power Divider With Wide Tuning Frequency Range and Good Reconfigurable Responses, IEEE Trans. on Circuits and Systems II: Express Briefs, 2016;63(11):1054-1058.
- [11] Zhang T., Wang X., Che W., A Varactor Based Frequency-Tunable Power Divider With Unequal Power Dividing Ratio, IEEE Microwave and Wireless Components Letters, 2016;26(8):589-591.
- [12] Wang X., Ma Z., Ohira M., Chen C., Anada T., Compact Tunable Wilkinson Power Divider with Simple Structure, 2018 48th European Microwave Conference (EuMC), Madrid, 2018:41-44.
- [13] Wu B., Sun Z., Wang X., Ma Z., Chen C., A Reconfigurable Wilkinson Power Divider with Flexible Tuning Range Configuration, IEEE Trans. on Circuits and Systems II: Express Briefs, 2020;67(7):1219-1223.
- [14] Guo Z., Jiang D., Chen H., A compact tunable filtering-power divider based on liquid crystal, 2015 IEEE International Conference on Communication Problem-Solving (ICCP), Guilin, 2015:416-418.
- [15] Zhou W., Arslan T., Benkrid K., El-Rayis A. O., Haridas N., Reconfigurable feeding network for GSM/GPS/3G/WiFi and global LTE applications, 2013 IEEE International Symposium on Circuits and Systems (ISCAS2013), Beijing, 2013:958-961.
- [16] Zhou W., Arslan T., Flynn B., A reconfigurable feed network for a dual circularly polarised antenna array, 2013 IEEE 24th Annual International Symposium on Personal, Indoor, and Mobile Radio Communications (PIMRC), London, 2013:430-434.
- [17] Shairi N. A., Ahmad B. H., Wong P. W., Bandstop to Allpass Reconfigurable Filter Technique in SPDT Switch Design, Progress In Electromagnetics Research C, 2013;39:265-277.
- [18] Zobilah A. M. S., Shairi N. A., Zakaria Z., Fixed and Selectable Multiband Isolation of Double Pole Double Throw Switch Using Transmission Line Stub Resonators for WiMAX and LTE, Progress In Electromagnetics Research B, 2017;72:95-110.
- [19] Zobilah A. M. S., Shairi N. A., Zakaria Z., Wong P. W., Zahari M. K., Algumaei M. Y. Q., Nasser Z. A. A., Absorptive Filter Integrated Single Pole Double Throw Switch Using Switchable T-Shape Resonator for IoT Applications, Progress In Electromagnetics Research C, 2020;103:167-176.
- [20] Chen H., Che W., Cao Y., Feng W., Sarabandi K., Function-Reconfigurable Between SPDT Switch and Power Divider Based on Switchable HMSIW Unit, IEEE Microwave and Wireless Components Letters, 2017;27(3):275-277.
- [21] Hunter, I., Theory and Design of Microwave Filters, IET, (2001), No. 48.