

Development of Low-Cost IoT-Based Wireless Healthcare Monitoring System

Abstract. According to studies, up to 99 percent of alarms triggered in hospital units are false or clinically insignificant while indicating no genuine harm to patients. However, false alarms can lead to alert overload, causing healthcare workers to miss critical occurrences that could be harmful or even fatal. The purpose of this work is to tackle the problem by developing an integrated system that can continually track the patient's health condition utilising a cloud computing platform, allowing alerts to be targeted to the appropriate medical facility personnel in a timely and orderly manner. Arduino microcontrollers are used to collect health parameters such as temperature and pulse rate and provide a real-time monitoring system for medical practitioners. Multiple sensors and an RF transceiver are attached to a small microcontroller, forming a wearable module that the patient will wear. This wearable component is wirelessly connected to the main module consisting of a larger microcontroller, where the data is then uploaded to the database in the cloud through the internet. The data can then be accessed through a web-based terminal, providing medical practitioners access through the web page. If the system detects any abrupt changes to the patient's temperature or pulse rate, a push notification will be sent to the medical practitioner's Android smartphone so that immediate action can be taken. The system is scalable as multiple wearable modules can be connected to the main module, allowing monitoring of multiple patients simultaneously. More sensors can also easily be added to the wearable module to monitor other vital health parameters such as oxygen saturation and blood pressure. The testing has indicated that the system can achieve 99.4% accuracy in temperature monitoring and 86% accuracy for pulse monitoring.

Streszczenie. Według badań, do 99 procent alarmów wyzwalanych na oddziałach szpitalnych jest fałszywych lub nieistotnych klinicznie, jednocześnie wskazując na brak rzeczywistej szkody dla pacjentów. Jednak fałszywe alarmy mogą prowadzić do przeciążenia alertów, powodując, że pracownicy służby zdrowia przeoczą krytyczne zdarzenia, które mogą być szkodliwe lub nawet śmiertelne. Celem tej pracy jest rozwiązanie problemu poprzez opracowanie zintegrowanego systemu, który może w sposób ciągły śledzić stan zdrowia pacjenta z wykorzystaniem platformy przetwarzania w chmurze, umożliwiając kierowanie alertów do odpowiedniego personelu placówki medycznej w sposób terminowy i uporządkowany. Mikrokontrolery Arduino służą do zbierania parametrów zdrowotnych, takich jak temperatura i częstość tętna, oraz zapewniają lekarzom system monitorowania w czasie rzeczywistym. Wiele czujników i nadajnik-odbiornik RF są przymocowane do małego mikrokontrolera, tworząc moduł do noszenia, który będzie nosić pacjent. Ten element do noszenia jest bezprzewodowo połączony z głównym modulem składającym się z większego mikrokontrolera, gdzie dane są następnie przesyłane do bazy danych w chmurze za pośrednictwem Internetu. Dostęp do danych można następnie uzyskać za pośrednictwem terminala internetowego, zapewniającego lekarzom dostęp za pośrednictwem strony internetowej. Jeśli system wykryje jakiegokolwiek nagłe zmiany temperatury lub tętna pacjenta, na smartfon z systemem Android lekarza zostanie wysłane powiadomienie, aby można było podjąć natychmiastowe działanie. System jest skalowalny, ponieważ do modułu głównego można podłączyć wiele modułów do noszenia, co umożliwi jednoczesne monitorowanie wielu pacjentów. Do modułu do noszenia można łatwo dodać więcej czujników, aby monitorować inne ważne parametry zdrowotne, takie jak saturacja tlenem i ciśnienie krwi. Testy wykazały, że system może osiągnąć 99,4% dokładności w monitorowaniu temperatury i 86% dokładności w monitorowaniu pulsu. (Opracowanie taniego bezprzewodowego systemu monitorowania opieki zdrowotnej opartego na IoT)

Keywords: Internet of Things, IoT, Healthcare, Wireless Monitoring.

Słowa kluczowe: Internet Rzeczy IoT, ochrona zdrowia..

Introduction

Technology plays a vital role in the healthcare system. In hospitals, continuous monitoring of patient's health is required in order to observe their health conditions [1]. Studies show that up to 99 percent of alarms triggered in hospital units are false or clinically inconsequential, and do not indicate an actual threat to patient [2]. However, it creates a cacophony of noises, which can lead to false alarms and alert overload, causing healthcare workers to miss critical occurrences that could be harmful or even fatal. The use of technology can improve the medical system with sensory devices where the data can be stored and processed in the cloud system, and critical notifications can be sent directly to specific person through the usage of smart devices.

Internet of Things (IoT) refers to the number of physical devices connected to the internet that share data with other elements. Recently, there are a lot of sensors that are connected and embedded to the internet, such as temperature [3], liquid [4], light [5, 6] and frequency signal [7, 8] for monitoring purposes. IoT has been widely employed in various applications such as agriculture [9, 10, 11], transportation [12, 13, 14] and environment [15, 16, 17]. In the healthcare application, the health parameters such as glucose level, blood pressure, heartbeat rate, body temperature, and body temperature can also be monitored

using sensor devices [18]. These data can be stored through a cloud system and monitored by doctors, physicians or family members, regardless of place and time, with the help of the IoT platform.

Recently, the internet has become a major impact in healthcare and other industries that use wireless technology. These technologies can be expanded widely to be properly integrated with the hospital system [19]. For example, using Wi-Fi networks allow the collection of data from each patient. The data is stored in a cloud with the proper database system. Besides, radio frequency (RF) and Bluetooth also can be used in the healthcare system for short transmission that allows a wearable monitoring system to be implemented. Hence, this wireless evolution greatly affects the healthcare industry since it can provide seamless monitoring without the need for wires. The challenge in the healthcare system covers data management, where an IBM study shows that almost 80% of health data collected were not organized in a pre-defined manner [20]. Most of the patient records in hospitals were not handled properly because of the paper-based system. The lack of a centralized system to easily tracked patient's records can affect the treatment process [21]. Besides, the monitoring system used in a hospital requires constant supervision by the nurse or a doctor near the patient. The monitoring devices only provide alerts with beeping sounds

when the patient condition is critical. Lastly, based on World Health Organization (WHO) analysis, it is stated that heart disease was responsible for 17.9 million deaths in 2016 [22] while analysis on diabetes also show that up to 1.6 million deaths occurred in 2015 [23]. These diseases can be prevented in the early stages with continuous monitoring of pulse rate, glucose level, and other health parameters.

Previous Works

Amrutha K.R. et al. developed a system to remotely monitor the health parameters of elderly people [24]. The system is integrated with medicine reminder alerts, automatic ambulance alerts, and automatic wheelchair access features. Utilizing IoT, the system provides a remote monitoring system capable of managing health information exchange, automatic alert process, and data storage with encryption. The health parameters used for monitoring are body temperature, glucose level, electrocardiogram and blood pressure. The project uses three different controllers, which are Arduino UNO, Raspberry Pi 3 and PIC16f877a. Each controller has its separate function to process and collect the data. The Arduino controller was used to accept sensor input since the sensor provides analogue output, and Arduino has a built-in ADC and DAC converter to process the data. The sensor data from Arduino is sent using serial communication to Raspberry Pi 3 for IoT, GPS location, password door lock, ambulance alert, and cloud server. Finally, to control the servo motor for wheelchair application, a PIC16f877a microcontroller was used.

Bhoomika. B. K. et al. proposed a secure smart healthcare monitoring system based on IoT [25]. It uses a PIC18F46K22 microcontroller as an intermediate for sensors communication with IoT implementation. Since security has been the main issue due to unauthorized access to the system, the author encrypted the Wi-Fi module with a password that only allows medical practitioners access to the data. The project also added a GSM module to notify caretakers or doctors using SMS in a critical situation. Besides, the proposed project benefits the medical service due to its low power consumption, fast response and straightforward setup. Two parameters are being measured: body temperature and heartbeat. A digital thermometer is used for measuring to provide measurement up to 9-bit resolution and 0.5 °C accuracy. The system uses a pulse oximeter sensor to measure heart rate based on blood flow rate for heartbeat detection. In software configuration, the project utilized C language for microcontroller programming and HTML language for web programming.

In Shelar M. et al. review of wireless patient health monitoring systems [26], the researcher developed a monitoring system to monitor heartbeat and temperature. The system uses a Zigbee modem for wireless transmission to the computer system for data storage. It is mainly designed to be used for continuous monitoring in residential homes. The heartbeat sensor was designed using an operational amplifier, LED and photoresistor.

Lastly, A. Gondalia et al. proposed an IoT-based healthcare monitoring system for soldiers during wars using machine learning [27]. The researchers developed a wireless monitoring system that the soldiers utilize to monitor their health status, location and presence of explosive compounds nearby. The system worn by each soldier is integrated with the Zigbee module for wireless transmission to the squadron leader. Data collected from the web portal use the K-Means Clustering data analytic technique to predict different types of situations.

Real-Time Monitoring System

The main idea of the proposed system is to develop a low-cost integrated system that can continuously monitor health conditions wirelessly utilizing the IoT. Figure 1 shows the block diagram of the system. The system consists of 2 main parts: the wearable module and the main module. The wearable module consists of the temperature and pulse sensors placed on the tip of the fingers to detect the health parameters. The wearable module is highly scalable as more sensors such as oxygen saturation and blood pressure can easily be connected to the microcontroller in the module.

The main module consists of a more capable microcontroller and a Wi-Fi module, and it acts as the central controller between the wearable modules and the cloud. It can connect multiple wearable modules, suitable for being used in healthcare environments such as hospital's wards or medical clinics. The wearable and main modules are connected through the RF wireless transceiver, while the main module is connected to the internet through the Wi-Fi module. The data from the main modules are processed and then stored in the database in the cloud.

A dedicated web-based terminal is configured to allow for monitoring by the health practitioners to access the data. Apart from that, critical notifications can be pushed to Android smartphones through the Android application that has been developed, enabling swift action to be taken in case of an emergency.

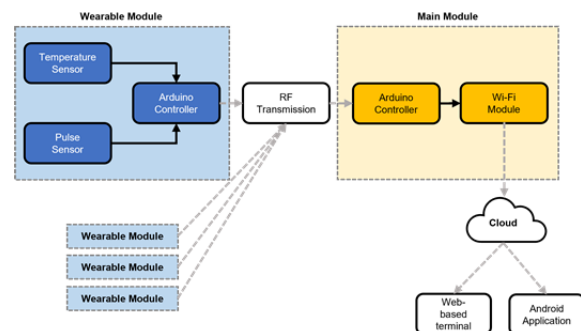

Fig. 1. Block diagram of the system

Hardware Requirements

A. Temperature Sensor

The LM35 temperature sensor can measure temperature from 0 °C up to 100 °C. This temperature range is limited due to the limitations of the silicon substrate. However, the temperature range provided by the sensor is adequate in detecting the normal range of human temperature. For temperatures outside this range, sensors with other substrate materials are required, such as gallium nitrate [28] and silicon carbide [29, 30].

The Arduino sketch is used to calculate the value of the temperature in degrees Celsius. The LM35 operates at 4 to 20 V of input voltage and have analogue output voltage. The sensitivity is 10 mV for each degree Celsius, which means that the output range of 0.3 V is equal to 30 °C. The analogue pin in Arduino converts the analogue voltage input to digital output range from 0 to 1023. The sensor consists of a p-n junction diode that employs CMOS technology, with its output voltage varying with resistance.

$$(1) \quad V_{out} = analogRead(tempPin) \times \frac{5}{1024}$$

$$(2) \quad Temperature = \frac{V_{out}}{0.01}$$

B. Pulse Sensor

The sensor circuit used in this system is developed using the principle of photoplethysmography (PPG) that responds to the relative changes of light intensity reflected during each pulse. If no light is reflected, the output remains constant, while if the photodiode detects more light reflected, it will provide an output voltage. As shown in Figure 2, the LED emits green light to the skin. The APDS-9008 light sensor detects the amount of light reflected for every heartbeat that depends on the saturation of blood flow. The input signal from the light sensor will be passed through a low-pass filter to clear unwanted high frequencies. The signal is then being amplified using the operational amplifier in MCP-6001 to get a better output signal. Lastly, the output voltage, which varies between 0.2 V to 1.5 V, is converted using an ADC converter in the Arduino controller. The output is adjusted within 2.5 V to 3 V for 5 V reference, converted to digital range between 500 to 600 for 1024 reference ADC.

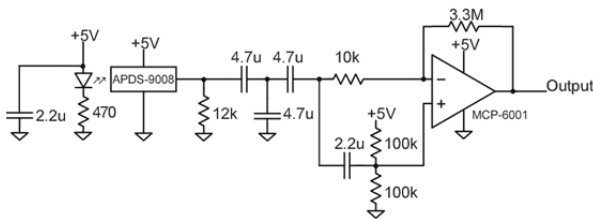

Fig.2. Circuit diagram of the pulse sensor

C. Arduino Controller

The system utilized two Arduino microcontrollers. The first controller is part of the wearable module, required to acquire data from the sensors and transmit the data wirelessly to the second controller in the main module.

As shown in Figure 3(a), Arduino Beetle is chosen to be the first controller. It operates using an Atmel AtMega32u4 processor. Due to its miniature size and low power requirement, it is suitable as the controller for the wearable component.

Next, the second controller is Arduino Uno, as shown in Figure 3(b). This controller is suitable because of its capability to support functions required by the system, such as serial transmission, analogue, and digital data conversion. From Figure 3(b), the board consists of multiple input/output pins programmed to do certain operations. The digital pin is used because it can act on a non-continuous time signal that can become an input or output in a system [31].

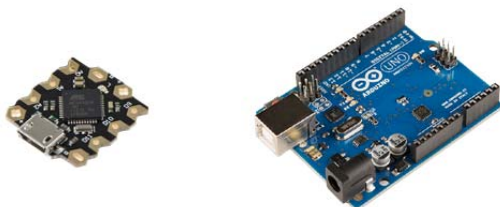

Fig.3. (a) Arduino Beetle and (b) Arduino Uno

D. Wireless Transceiver Module

HC-12 module, as shown in Figure 4, is used to create a wireless transmission between the microcontrollers. The module uses radio frequency signals and operates on frequencies between 433.40 to 473.00 MHz, providing up to 100 channels [32]. Besides that, the module uses half-duplex serial communication that can transmit data up to

1km in open space. Two modules are needed to act as a transmitter and receiver.



Fig.4. HC-12 transceiver module

E. Wi-Fi Serial Transceiver Module

The ESP8266 module, as shown in Figure 5, is integrated with TCP/IP protocol to provide internet access to any controller board. The module uses UART communication and supports up to 3.3V of DC voltage. The module is a low-cost board that comes with onboard processing and storage functions. These features allow it to be integrated into IoT-based projects and provide minimal loading runtime.



Fig.5. ESP8266 Wi-Fi module

Software Requirements

Proteus software is used to design the circuit. The software allows schematic design, simulation, printed circuit board (PCB) layout design and controller programming simulation. As shown in Figure 6, the circuit has been designed using hardware modules. Simulation in Proteus allows measurement of the voltage across each pin. Besides, the controller board also can be uploaded with program code to check the operation and functionality of the circuit.

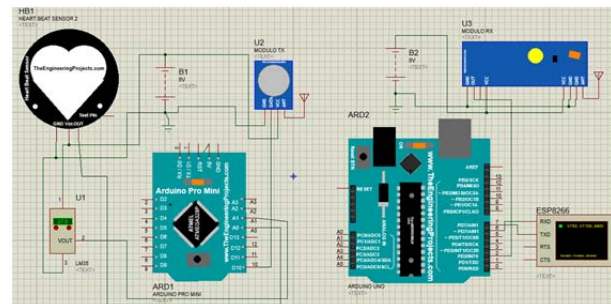

Fig.6. The circuit built using Proteus software

Arduino Integrated Development Environment (IDE) is used to write code and upload it into the Arduino board. Arduino IDE uses serial transmission on the USB port to upload the completed program sketch into the controller. Besides, the software also has extra features called serial monitor that allows displaying serial data from Arduino into the monitor using the *Serial.begin* command. The IDE software is used throughout the project to write and compile the codes.

A database is developed to store the temperature and pulse sensor readings for real-time monitoring. Each time an HTTP request is received from the Arduino controller, the data will be stored in the database. A website is created to display the temperature and pulse sensor readings in a table form that also includes the timestamp. An example of the website view is shown in Figure 7. The table consists of

four columns which are created using HTML syntax. Data displayed in the table are fetched from the database using the MySQL command. This website allows real-time monitoring through any device with a web browser that has a connection to the internet.

Android Studio is used to create an Android application that can be used for monitoring purposes and provide push notifications to Android devices when patients are in critical condition. The application retrieves and displays data instantly from the website created. The application uses Firebase Messaging Cloud (FCM) to get notifications by using two main services. The first service is Firebase Messaging Service, which is mainly used to set up a notification system each time the function is called from the PHP curl function. The second service is the Firebase Instance ID service, and it is mainly used to retrieve the unique device token ID of the smartphone and store it into a database. The service allows notification to be called when needed using the token ID.

No	Timestamp	Temp. (°C)	Pulse (bpm)
1093	2021-05-01 08:40:00	36.5	65
1094	2021-05-01 08:40:30	36.6	69
1095	2021-05-01 08:41:00	36.6	73
1096	2021-05-01 08:41:30	36.7	71
1097	2021-05-01 08:42:00	36.6	70
1098	2021-05-01 08:42:30	36.6	70
1099	2021-05-01 08:43:00	36.5	68
1100	2021-05-01 08:43:30	36.5	67
1101	2021-05-01 08:44:00	36.5	67
1102	2021-05-01 08:44:30	36.5	69

Fig.7. Website design for monitoring purpose

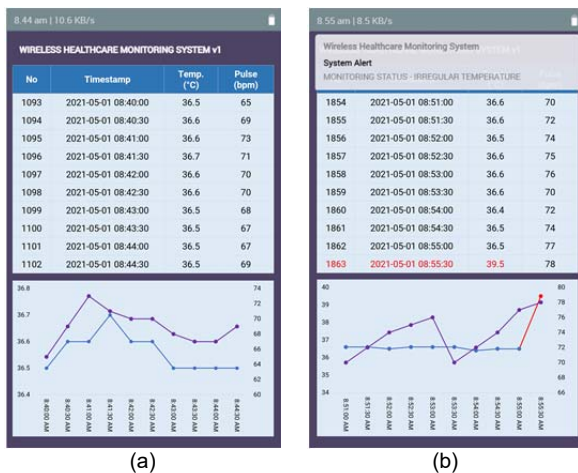

Fig.8. Android application display for (a) normal condition and (b) irregular condition with push notification.

Push notifications can be sent to any Android devices that are set up to receive the notification. Each person has a different pulse rate and body temperature, depending on size, age, sex, and metabolism. So, only physicians or doctors can determine the acceptable range for a specific person in normal condition. In this system, the normal range for the temperature is set between 36 to 37.5 °C and pulse rate between 60 to 100 bpm. Hence, whenever the health

parameters detected are not within the threshold range, the system will send an alert through a push notification to the Android device installed with the Android application and has been set up to connect to the database. Figure 8 shows an example of the application interface that shows a push notification in normal and irregular conditions.

Hardware System Design

The final design for the prototype, as shown in Figure 9, consists of 2 main parts: the wearable module and the main module. The wearable module consists of sensors that can be worn on the fingers. The sensors are connected to the Arduino Beetle. A custom case is created using a 3D printer to house the microcontroller, wireless transceiver and power supply.

The main module, which consists of the Arduino Uno, wireless transceiver, Wi-Fi module and power supply, is housed in a larger custom case. Both modules are connected to each other through the wireless transceiver, while the main module is connected to the internet through the Wi-Fi module.



Fig.9. Prototype design

The total cost for the prototype with a single wearable module is RM 175.00, equivalent to USD 40.00. Table 1 shows the cost breakdown for the main components of the system. This system is considered a low-cost solution for monitoring health parameters wirelessly as other comparable systems in the market cost considerably more.

Table 1. The total cost for the system

Component	Quantities	Cost (RM)	Total (RM)
Arduino Beetle	1	40.00	40.00
Arduino UNO R3	1	25.00	25.00
HC-12 transceiver module	2	25.00	50.00
LM35 temperature sensor	1	8.00	8.00
ESP8266 Wi-Fi module	1	12.00	12.00
Pulse sensor	1	20.00	20.00
Li-ion Battery 7.4 V	1	20.00	20.00
Total			175.00

To ensure that the system could be constructed at a reasonable cost, the components utilised in the project are standard components that are readily available on the market. However, the choice of the components does not in any way compromise the functionality or the accuracy of the system, as evidenced by the results presented in the next section.

Results and Discussion

The temperature sensor LM35 used in this project is a low-cost sensor with 0.5 °C sensitivity. In this part, the sensor had undergone several tests and was compared with the value obtained using a thermometer. Figure 10 shows the comparison of 9 readings between LM35 and the thermometer. The average temperature obtained using

LM35 is around 33.8 °C, compared to 33.6 °C with the thermometer; hence, the error percentage is 0.6%. Therefore, the accuracy of the LM35 sensor is around 99.4%.

$$(3) \quad \%error = \frac{|33.8-33.6|}{33.6} \times 100\% = 0.6\%$$

$$(4) \quad \%accuracy = 100\% - 0.6\% = 99.4\%$$

The pulse sensor is also being tested for its accuracy. Figure 11 shows the comparison of 10 readings between the pulse sensor used in this system and the optical sensor used in the Samsung smart device. The BPM obtained using the pulse sensor have slight difference between actual measurement. From this analysis, the average BPM obtained using the pulse sensor is 60.2, and the optical sensor is 69.9, hence the percentage of difference of 14%. Therefore, the accuracy of the pulse sensor used in this system is around 86% if compared to the optical sensor widely used in Samsung smart devices.

$$(5) \quad \%error = \frac{|60.2-69.9|}{69.9} \times 100\% = 14\%$$

$$(6) \quad \%accuracy = 100\% - 14\% = 86\%$$

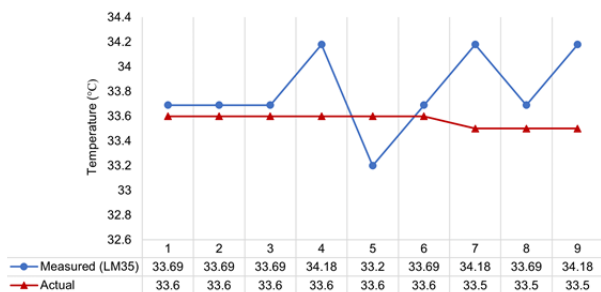

Fig.10. The temperature comparison

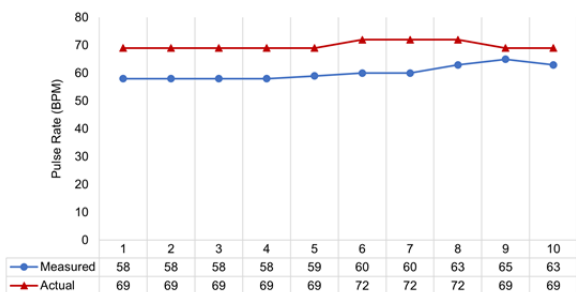

Fig.11. Measured and actual BPM

HC-12 transceiver module is being tested for wireless transmission strength. The transmitted power can be adjusted, which will affect the strength of the signal transmitted to the receiver. As shown in Table 2, when transmitter power is at 20 dBm, it can achieve a maximum distance of 50 m. The maximum range is quite low because the module uses a small antenna that transmits waves at a smaller range and obstacles that block the signal. Every time the transmit power is reduced by 6 dB, the communication distance is reduced by half, as shown in Fig. 12.

Table 2. The parameters of the sensor

Power (mW)	Power (dBm)	Distance (m)
100	20	50
25	14	25
6.3	8	12.5
1.58	2	6.25

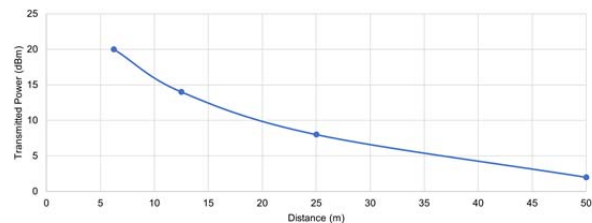

Fig.12. Power transmitted vs distance

Conclusion

This work has resulted in the development of a low-cost, high accuracy health monitoring and alert system. The results obtained are practically accurate by comparing the measured and controlled values. The system produced 99.4% accuracy in temperature monitoring and 86% accuracy for pulse monitoring. In comparison to the previous works detailed in the Previous Work section, this system delivered consistent and accurate measurements, which is critical so that the alert generated is accurate and actionable.

Overall, the system has performed exceptionally well considering the low cost of approximately RM 175.00 or equivalent to around USD 40.00 per unit consisting of a wearable module, compared to the existing solutions in the market, which cost considerably more. Besides, the system is easy to use, where the health parameters will be automatically uploaded to the database and can be monitored through any device with internet connectivity. Push notification is also provided through the Android application developed, offering instant warning whenever the parameters fall out of the specified range.

The wearable module is scalable as more sensors can easily be added to monitor other important health parameters such as oxygen saturation and blood pressure. The system is also scalable as multiple wearable modules can be easily added. Hence, the system is suitable for use in the healthcare environment. The system has proved that a low-cost solution that provides excellent accuracy is possible, allowing for automated wireless health care monitoring available to the masses.

To address the security and privacy issues that might arise related to patients' data, several solutions can be implemented to further improve this system in its next iteration. The access control mechanism can be implemented where the ability to physically access the system can be controlled at a hardware level by using a special access device such as a USB thumb drive with built-in security or authentication key. Secure communications between the devices and the cloud can be provided by using lightweight encryption suitable for IoT. Data privacy protection can be ensured by implementing routine integrity checks, security breach checks and limiting the availability of patients' data to authorized users only.

Finally, it is important to note that this system is at the early stage of development and in order to get the system operational in healthcare facilities, it needs to pass stringent tests, adhere to all applicable standards, and be certified as medical equipment by medical regulatory bodies.

Authors are grateful to Universiti Teknikal Malaysia Melaka for the financial support through Short Term Research Grant PJP/2020/FKEKK/PP/S01750. The authors would also like to thank the Centre for Telecommunication Research & Innovation (CeTRI), Fakulti Kejuruteraan Elektronik & Kejuruteraan Komputer, Universiti Teknikal Malaysia Melaka (UTeM) for the support given.

Authors: Mohd Shahril Izuan Mohd Zin, *Universiti Teknikal Malaysia Melaka*, E-mail: shahril@utem.edu.my; Muhammad Ameer Khan bin Mustafah, *Universiti Teknikal Malaysia Melaka*, E-mail: ameer7860khan@gmail.com; Dr. Faiz Arith, *Universiti Teknikal Malaysia Melaka*, E-mail: faiz.arith@utem.edu.my; Associate Professor Azmi Awang Md Isa, *Universiti Teknikal Malaysia Melaka*, E-mail: azmiawang@utem.edu.my; Liawas Barukang, *Sabah Net Sdn. Bhd.*, E-mail: liawas@sabah-net.com; Professor Garik Markarian, *Lancaster University, United Kingdom*, E-mail: g.markarian@lancaster.ac.uk.

REFERENCES

- [1] M. Aminian. A Hospital Healthcare Monitoring System Using Wireless Sensor Networks, *J. Heal. Med. Informatics*, Vol. 4, No. 2, pp. 4-9, 1993.
- [2] Fernandes, C.O., Miles, S., De Lucena, C.J.P. & Cowan, D. 2019, "Artificial intelligence technologies for coping with alarm fatigue in hospital environments because of sensory overload: Algorithm development and validation", *Journal of Medical Internet Research*, vol. 21, no. 11.
- [3] S. Konishi and A. Hirata. Flexible Temperature Sensor Integrated with Soft Pneumatic Microactuators for Functional Microfingers, *Sci. Rep.*, vol. 9, pp. 15634, 2019
- [4] S. H. Meriam Suhaimy, N. Ghazali, F. Arith, and B. Fauzi. Enhanced Simazine Herbicide Degradation by Optimized Fluoride Concentrations in TiO₂ Nanotubes Growth, *Optik*, vol. 212, pp. 164651, 2020.
- [5] M. A. Azhari, F. Arith, F. Ali, S. Rodzi, and K. Karim. Fabrication of Low Cost Sensitized Solar Cell Using Natural Plant Pigment Dyes, *ARPN J. Eng. Appl. Sci.*, vol. 10, no. 16, pp. 7092–7096, 2015.
- [6] F. Arith, S. A. M. Anis, M. M. Said and C. M. I Idris. Low Cost Electro-Deposition of Cuprous Oxide P-N Homo-Junction Solar Cell, *Adv Mat Res.*, vol. 827, pp. 38 - 43, 2014.
- [7] Mahyuddin, M.F.M., Isa, A.A.M., Zin, M.S.I.M., Afifah, M.A.H., Manap, Z. & Ismail, M.K., "Overview of positioning techniques for LTE technology", *Journal of Telecommunication, Electronic and Computer Engineering*, vol. 9, no. 2-13, pp. 43-50, 2017.
- [8] Isa, A.A.M., Markarian, G., Isa, M.S.M., Zakaria, Z. & Zin, M.S.I.M., "Simulation of virtual MIMO base stations for mobile location in IMT-Advanced networks", *2012 IEEE Asia-Pacific Conference on Applied Electromagnetics, APACE 2012 - Proceedings*, pp. 176, 2012.
- [9] Boonsong, W., "Internet of Things for Enhancement the Quality of Community: Case Study of Aquatic Nursery in Songkhla Lake Basin", *Przeglad Elektrotechniczny*, vol. 97, no. 3, pp. 138-140, 2021.
- [10] Jayaraman, P.P., Yavari, A., Georgakopoulos, D., Morshed, A. & Zaslavsky, A., "Internet of things platform for smart farming: Experiences and lessons learnt", *Sensors (Switzerland)*, vol. 16, no. 11, 2016.
- [11] Muangprathub, J., Boonnam, N., Kajornkasirat, S., Lekbangpong, N., Wanichsombat, A. & Nillaor, P., "IoT and agriculture data analysis for smart farm", *Computers and Electronics in Agriculture*, vol. 156, pp. 467-474, 2019.
- [12] Sharma, S. & Kaushik, B., "A survey on internet of vehicles: Applications, security issues & solutions", *Vehicular Communications*, vol. 20, 2019.
- [13] Paul, J.J., Jone, A.A., Sagayam, M., Packiavathy, I.S.V., Jesintha, E., Jemimah Rinsy, J., Dang, H. & Pomplun, M., "IoT based remote transit vehicle monitoring and seat display system", *Przeglad Elektrotechniczny*, vol. 97, no. 5, pp. 140-145, 2021.
- [14] Agarwal, Y., Jain, K. & Karabasoglu, O., "Smart vehicle monitoring and assistance using cloud computing in vehicular Ad Hoc networks", *International Journal of Transportation Science and Technology*, vol. 7, no. 1, pp. 60-73, 2018.
- [15] Dhingra, S., Madda, R.B., Gandomi, A.H., Patan, R. & Daneshmand, M., "Internet of things mobile-air pollution monitoring system (IoT-Mobair)", *IEEE Internet of Things Journal*, vol. 6, no. 3, pp. 5577-5584, 2019.
- [16] Marques, G., Ferreira, C.R. & Pitarma, R., "Indoor Air Quality Assessment Using a CO₂ Monitoring System Based on Internet of Things", *Journal of Medical Systems*, vol. 43, no. 3, 2019.
- [17] Evizal, A.K., Irie, H., Rosa, S.L. & Othman, M., "Multi-sensor system for monitoring of river water pollution", *Przeglad Elektrotechniczny*, vol. 96, no. 4, pp. 62-66, 2020.
- [18] Nasrullah Patel. Internet of Things in Healthcare: Applications, Benefits, and Challenges, *Peerbits*, 2018, available at <https://www.peerbits.com/blog/internet-of-things-healthcare-applications-benefits-and-challenges.html>.
- [19] Tian, S., Yang, W., Grange, J.M.L., Wang, P., Huang, W. & Ye, Z. 2019, "Smart healthcare: Making Medical Care More Intelligent", *Journal of Global Health*, vol. 3, no. 3, pp. 62-65.
- [20] Denise Amrich. Within two years, 80% of all medical data will be unstructured, *ZDNet Health*, 2013, available at <https://www.zdnet.com/article/within-two-years-80-of-all-medical-data-will-be-unstructured/>.
- [21] R. K. Kodali, G. Swamy, and B. Lakshmi. An implementation of IoT for healthcare, *IEEE Recent Adv. Intell. Comput. Syst. RAICS 2015*, pp. 411-416, December 2015.
- [22] WHO. Cardiovascular diseases (CVDs), *World Health Organization*, 17 May 2017, available at [https://www.who.int/news-room/fact-sheets/detail/cardiovascular-diseases-\(cvds\)](https://www.who.int/news-room/fact-sheets/detail/cardiovascular-diseases-(cvds)).
- [23] WHO. Diabetes, *World Health Organization*, 8 June 2020, available at <https://www.who.int/news-room/fact-sheets/detail/diabetes>.
- [24] Amrutha K.R., Hariitha S.M., Hariitha Vasu M., Jency A. J., Sreechithra Sasidharan and Jomon K. Charly., IOT based Medical Home, *International Journal of Computer Applications*, Vol. 165, No. 11, pp. 8-14, May 2017.
- [25] Bhoomika B. K. and K. N. Muralidhara, Secured Smart Healthcare Monitoring System Based on IoT, *International Journal on Recent and Innovation Trends in Computing and Communication*, Vol. 3, No. 7, pp. 4958–4961, 2015.
- [26] Shelar M, Singh J and Tiwari M., Wireless Patient Health Monitoring System, *International Journal of Computer Applications*, Vol. 62, No. 6, January 2013.
- [27] A. Gondalia, D. Dixit, S. Parashar, V. Raghava, A. Sengupta, and V. R. Sarobin. IoT-based Healthcare Monitoring System for War Soldiers using Machine Learning, *Procedia Comput. Sci.*, Vol. 133, pp. 1005–1013, 2018.
- [28] X. Li, T. Pu, L. Li and J. Ao. Enhanced Sensitivity of GaN-Based Temperature Sensor by Using the Series Schottky Barrier Diode Structure, *IEEE Electron Device Lett.*, vol. 41, no. 4, pp. 601-604, 2020.
- [29] F. Arith, J. Urresti, K. Vasilevskiy, S. Olsen, N. Wright and A. O'Neill. Increased Mobility in Enhancement Mode 4H-SiC MOSFET Using a Thin SiO₂/Al₂O₃ Gate Stack, *IEEE Electron Device Lett.*, vol. 39, Issue 4, pp. 564 - 567, 2018.
- [30] J. Urresti, F. Arith, S. Olsen, N. Wright and A. O'Neill. Design and Analysis of High Mobility Enhancement-Mode 4H-SiC MOSFETs Using a Thin-SiO₂/Al₂O₃ Gate-Stack, *IEEE Trans Electron Devices*, vol. 66, Issue 4, pp. 1710 - 1716, 2019.
- [31] Sudhan, R. H., Kumar, M. G., Prakash, A. U., Devi, S. A. N. U. R., & Sathiya, P. Arduino ATMEGA-328 microcontroller, *International Journal of Innovative Research in Electrical, Electronics, Instrumentation and Control Engineering*, Vol. 3, No. 4, pp. 27–29, 2015.
- [32] L. Joseph, M. Sonia, P. D. Riya, S. Tom, S. P. Andrews, and M. John. RF Chat, *Int. Res. J. Eng. Technol*, Vol. 4, No. 4, pp. 1889–1893, 2017.