

Smart Mailbox Notification System with Solar Battery Charging based on IoT

Muhamad Athir Mohd Sidek, Adam Samsudin*, Nor Hafizah Hussin, Rahaini Mohd Said, Siti Haryanti Hairol Anuar, Nur Azura Noor Azhuan and Nurul Hajar Mohd Yusoff

Abstract—The Smart Mailbox is designed to make users more aware of the existence of crucial notifications and messages in their current mailboxes. Busy people have been known to forget to take critical letters, invoices, and documents, and have even missed key deadlines due to their neglect and forgetfulness in checking their mailboxes. This happens because citizens lack a new solution or updated technology to handle the issue. The goal of this project is to create a solar-powered smart mailbox notification system that notifies the user via their smartphone. The essential components of this project are an IR sensor, a Blynk application, and solar power. The Blynk application function is to receive notifications and count letters inside the mailbox and the IR sensor identifies mail or small deliveries. The outcome shows that the initiative met all of its goals, and users will receive notifications from Blynk apps in less than 4 seconds informing them of incoming letters or other important documents. Solar power is selected as the main power used due to low environmental impacts and reduced electrical monthly bills.

Index Terms—IoT , notification system, smart mailbox, solar battery

I. INTRODUCTION

Smart homes and Internet of Things (IoT) technologies are adding a lot of excitement to our daily lives. A smart house is a handy configuration of appliances and gadgets that can be remotely monitored and controlled by a smartphone or other networked device, including thermostats, lights, windows and doors [1-3]. Smart home technology makes it easier and more accessible for homeowners. In 2016, the market for home automation was estimated to be worth roughly 24 billion dollars. By 2022, it is projected to increase to roughly 53.5 billion as more individuals start utilizing smart home technology [4].

The emergence of electronic mail or known as e-mail has

This manuscript is submitted on 24 May 2023, revised on 12 September 2023, accepted on 6 December 2023 and published on 30 April 2024. Adam Samsudin is with Faculty of Electrical Technology and Engineering (FTKE), Universiti Teknikal Malaysia Melaka (UTeM), Hang Tuah Jaya, 76100 Durian Tunggal, Melaka, Malaysia.

*Corresponding author
Email address: adam.samsudin@utem.edu.my

1985-5389/© 2023 The Authors. Published by UiTM Press. This is an open access article under the CC BY-NC-ND license (<http://creativecommons.org/licenses/by-nc-nd/4.0/>).

resulted in people forgetting to inspect their physical mailboxes owing to their busy schedules. A question of burning importance is: When to check the mailbox? Sometimes the mailboxes are placed far from the front entrance of the house, while in some situations they are placed on the opposite side of a busy street. Sometime the parcel is being lost or even damaged due to not properly put in place [5]. These conditions have been one of the key reasons for the loss of critical notifications or messages, as well as other concerns, due to their insensitivity to the existence of such warnings in the first place. Residents in residential areas near the city, notably in flats, condos, and shopping Centre lots, often lose mail and are unaware of its existence in the mailbox, according to the results of a study done on them. The Smart Mailbox is fitted with a high-sensitivity sensor and an Esp 8266 to address these problems [6].

People become preoccupied with everyday issues over time for a variety of personal reasons and obligations, but some of them find it impossible to unwind at all, which leads to stress. According to the study, stress has a greater effect on focus and attention than memory. Yet, this can make it harder for men to remember new knowledge. The mind will be distracted by other problems and ideas, which it will eventually forget. As a result, there is a serious risk of negative side effects on other things as well as adverse effects on people. Men need reminders frequently since they tend to forget things, and most people need a lot of encouragement at first before building up enough momentum to finish what needs to be done consistently.

People like simple things because technology has permeated every aspect of society to the point where it is hard to avoid it. According to Rescue Time, an iOS and Android app that tracks phone use, individuals spend an average of three hours and fifteen minutes on their phones every day, with the top 20% spending upwards of four and a half hours [7]. 58 times a day, each person checks their phone to send or receive text messages or to check their email. Using applications on mobile devices may increase consumer productivity.

Smart mailboxes have many advantages when users can track and save time to regularly check their physical mailbox. It will also boost the manufacturer's products [8]. Mailbox manufacturers compete for design supremacy. They said the first company to use a smart mailbox would have an advantage [9]. This makes everyday items smart, interconnected and communicative devices can simplify and improve industrial production and assisted living [10]. Smart mailboxes are

capable of detecting content in a mailbox from a distant location, independent of the distance between the mailbox and the user [11].

Several related works are found in the literature on developing a smarter mailbox. It found that the work in [12] uses a 915 MHz TI radio transceiver for communication, which consumes 45 mA during transmission [13]. In [14], notification to the smartphone is only sent when the user is close to the mailbox. Thus, the notification is not real-time. The work in [15] uses a Wi-Fi-equipped Raspberry Pi (RPi) in the mailbox.

However, In this project, an IoT-connected smart mailbox powered by solar energy is created. When new mail is placed in the mailbox, it automatically sends a notification to the owner's smartphone via the Blynk app. The notification notifies the owner when the mail has arrived, saving them the trouble of making an unneeded journey to the mailbox.

II. METHODOLOGY

The requirement of this research was to develop a smart mailbox with a notification system using solar power as an alternative source. Hence, users will always be alert when they receive a small parcel or important documents. The purpose of this project is not to use electricity that much as this project will use renewable energy which is solar energy and can further save more cost in the future. Not only that this Smart mailbox can be monitored by an app called Blynk app from a mobile phone. It will notify through the app if any documents or parcel was inserted in the Smart Mailbox. Blynk is an application platform for mobile OS (iOS and Android) devices for controlling Internet-connected modules such as Arduino, Raspberry Pi, ESP8266 and WEMOS D1. The Blynk application is simple to use on a smartphone. The purpose of the Blynk program is to get notifications when anything like a sensor contacts the app, and the app sends a notice. When anything contacts the sensor, the Blynk app sends a notice to the user. As a result, users will be aware that something has occurred.

Fig. 1. shows the flowchart of this research which shows that this project started by finding the main objective of why this invention is needed as mentioned in the introduction part. Some previous research on smart mailboxes has been done and the methodology of this project has been identified by designing the schematic circuit of smart mailboxes. The flowchart of this project is completely explained and discussed in this section and continues in the next paragraph.

Fig. 2. shows the block diagram for the operation general system in this project. It shows that the general system functioning of this project consists of solar, charger controller, and battery. This charger controller will be placed between the solar panel and the battery to provide electrical energy. A microcontroller, the Esp 8266, is also used in this project to manage the Smart Mailbox and the associated notification system.

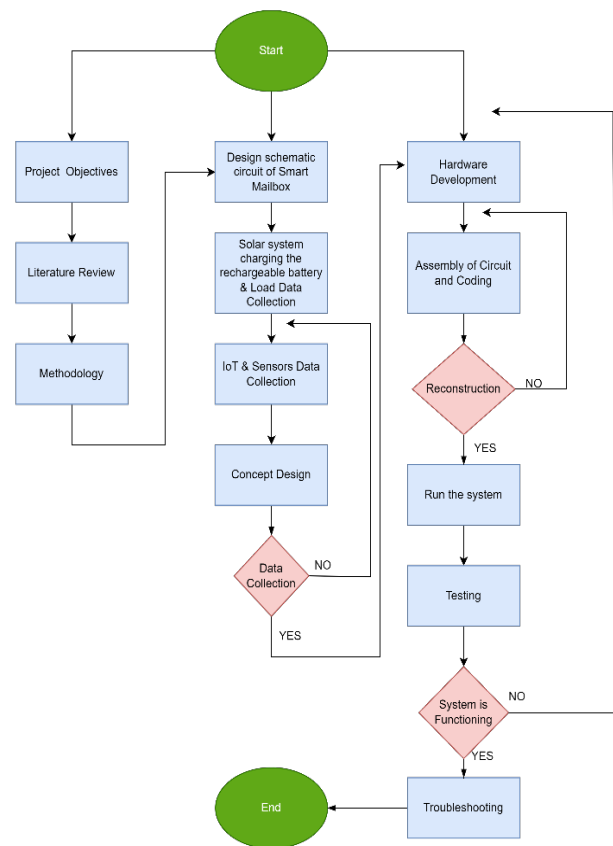

Fig. 1. The flowchart for the IoT-based development of a smart mailbox notification system

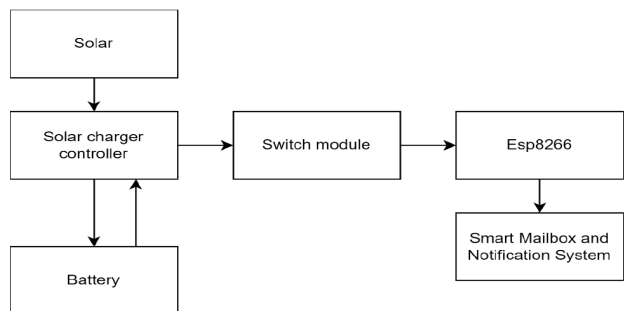

Fig. 2. Block diagram for the operation of the general system

In terms of software, the Arduino Ide is used to code. The Arduino Ide is simpler to use than other programming packages. Because it can read input signals and convert them to output signals, it may be used in situations when the sensor detects an obstruction in the path. In general, the Arduino IDE software is an open source, C and C++ based programming language that is available in most operating systems. Understanding a C++-based language is essential to modify programming instruction. An Esp8266 is used as the system microcontroller in this project.

Proteus Software is used for circuit design, and the code is uploaded to the Arduino in Proteus Software to check for flaws or functionality. This is because, before the hardware component is completed, it must be simulated to ensure that there will be no issues. Once these sections are error-free, the

hardware design process will commence. This is the most important part since it must reflect the final shape and look of the project.

The general system functioning of the project consists of solar, charger controller, and battery. This charger controller will be placed between the solar panel and the battery to provide electrical energy. A microcontroller, the Esp 8266, is also used in this project to manage the Smart Mailbox and the associated notification system.

The smart mailbox designed for this project consists mainly of NodeMcu ESP8266, two IR sensors, a buzzer and ESP8266 Wi-Fi module. The coding and program are uploaded to NodeMcu Esp8266 via USB cable from Arduino IDE. Besides, The ESP8266 WIFI Module acts as wireless connectivity between the smart mailbox and the clouds.

In general, the Arduino IDE software is an open source, C and C++ based programming language that is available in most operating systems. Understanding a C++ based language is essential to modify programming instruction. An Esp8266 is used as the system microcontroller in this project.

Fig. 3. shows the electrical design incorporates the design simulations circuit and component type that has been chosen for use in this project. As part of the project's circuit design and programming, Proteus 8 software is used to create the circuit and simulate it for testing.

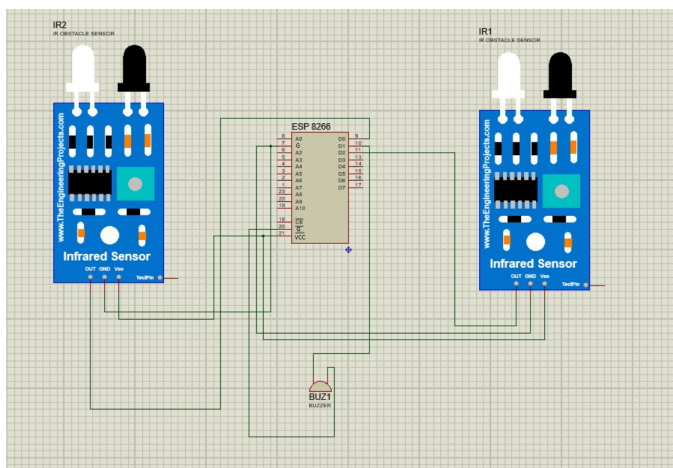

Fig. 3. Schematic diagram

This research is based on a real mailbox structure design. The size dimension of Length x Width x Height for this mailbox is 30cm x 15cm x 40cm and for the battery box the size dimension is 30cm x 21cm x 15cm and for the solar panel size dimension 37cm x 24cm. Fig. 4. shows the front view of the mailbox, Fig. 5. shows the battery box and Fig. 6. shows the solar panel.

The hardware part is the development of the smart mailbox made up of, a microcontroller, and a sensor. Hardware development includes circuit design and the operation of the IR sensor. The circuit is made up of an ESP8266 Wi-Fi module, and a power supply. The IR sensor is the most important component in this project for detecting incoming mail or small parcel.

Turning on the configured Wi-Fi and input hardware devices such as the IR sensor and buzzer is required to activate and put the smart mailbox into operation. The IR sensor will turn on the green light when the ESP8266 connects to a Wi-Fi modem that is suitable for ESP8266 which can connect to 2.4 GHz WIFI. The IR sensor will turn on the green light. After the ESP8266 is connected to the Wi-Fi the operation will be processed. First, the IR sensor will detect the mail or small parcel that go through the sensor and then the buzzer will make the sound and the phone that have been downloaded the Blynk app and logged in to the same user as the smart mailbox will get the notification from the Blynk apps. Fig. 7. below shows the full hardware development of the Smart Mailbox Notification System with Solar Battery Charging.



Fig. 4. The front view of the smart mailbox

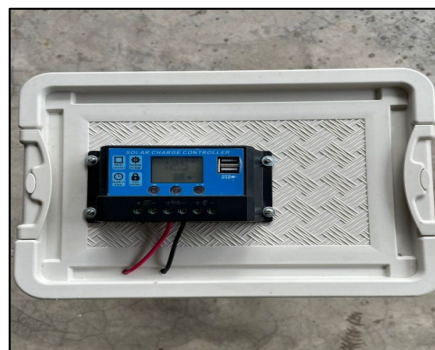

Fig. 5. The front view of battery box

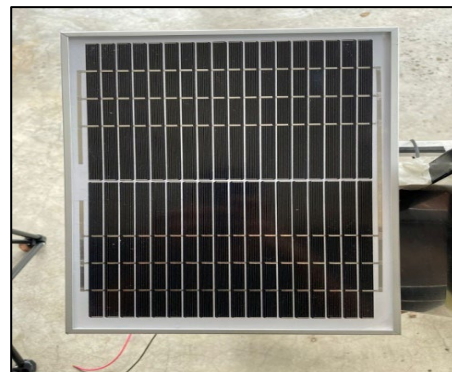

Fig. 6. The front view of the solar panel



Fig. 7. The Smart Mailbox Notification System with Solar Battery Charging

III. RESULTS AND DISCUSSION

After the development of the smart mailbox notification system prototype for mail posts using IoT and solar energy, it was tested and verified that the solar panel, the charge controller and the battery work together properly. Then one of the main functions of this system was tested by putting envelopes inside the mailbox. When the smart mailbox connects to the power supply which is at the solar charger controller the Smart mailbox will turn on. After that, the Wi-Fi adapter must be turned on adapter where the username and password must be the same as the program that has been set up in the Arduino Ide as shown in Fig. 9.

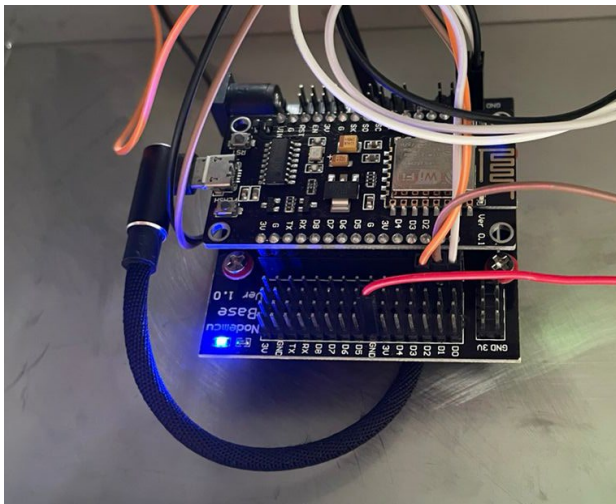

Fig. 8. Esp8266 is ON

```
char auth[] = BLYNK_AUTH_TOKEN;
char ssid[] = "Yeke";
char pass[] = "athirsidek";
```

Fig. 9. Username and Password in Arduino IDE

Next, connect the ESP8266 Module in the smart mailbox with the adapter WIFI and wait to connect to the WIFI. After that, the smart mailbox is connected to the supply from the battery box and the Wi-Fi adapter is turned on and the two IR sensors will show the light the Esp8266 will automatically connect to the adapter Wi-Fi because the username and the password of the Wi-Fi has already been set in the program and the smart mailbox will be ready to use.

In this project, the data and notifications can be monitored from the smart mailbox with the Blynk application. This smartphone app displays all the data notifications as shown Fig. 10.

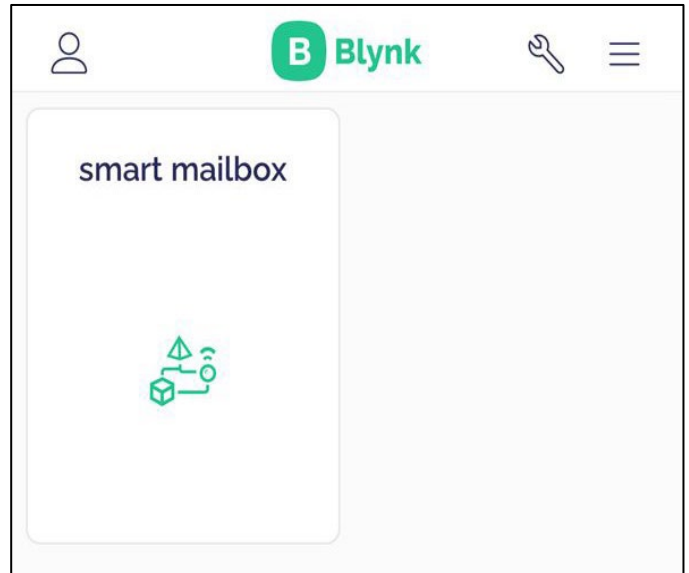

Fig. 10. Smart Mailbox in Online condition

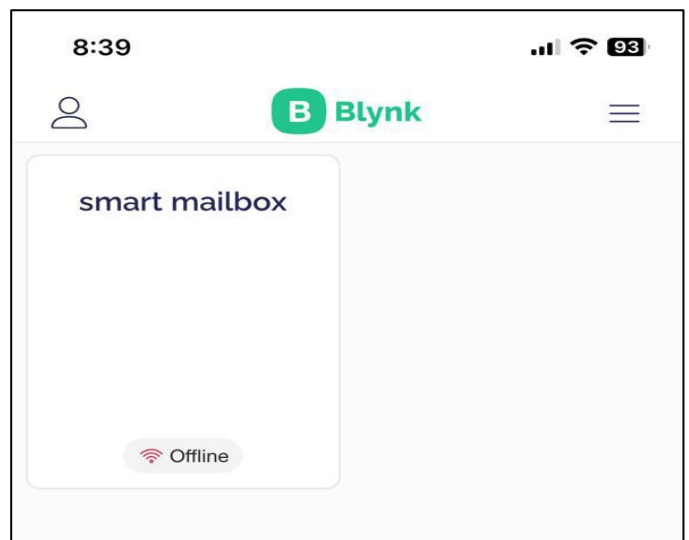

Fig. 11. Smart Mailbox in Offline Condition

When the smart mailbox connects to the power supply which is at the solar charger controller the Smart mailbox will turn on. After that the Wi-Fi adapter must be turned on the adapter

username and password must be the same as the program that has been set up in the Arduino Ide. Esp8266 will send a notification to the cloud when an IR sensor detects any mail or a small package, and the owner of the smart mailbox will receive the Blynk notification on their phone. The Blynk apps also keep track of the number of packages that smart mailbox owners have received in their mailboxes. This count can also be reset at any moment, all it takes is a quick click of the reset button to make the counting clear. Once the owner has placed all the mail and small packages in the smart mailbox.

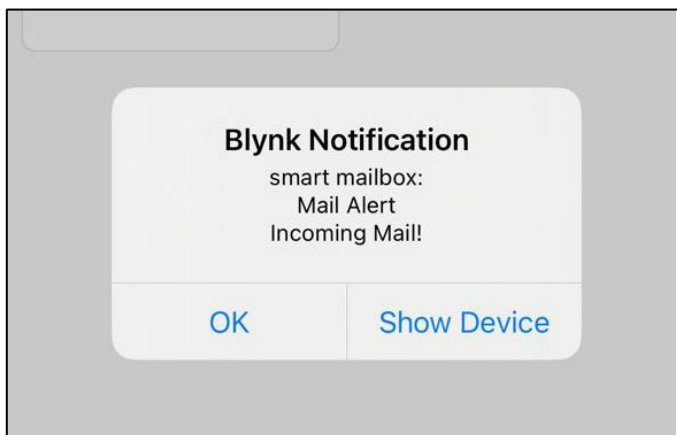

Fig. 12. Notification from Blynk Apps

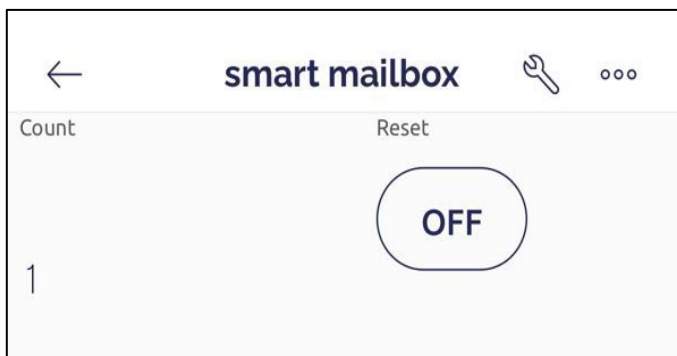

Fig. 13. Blynk notification shows that one mail in the mailbox



Fig. 14. Blynk notification shows that reset mail count to zero

The tests were conducted on 10 attempts with three different

letter envelopes, with the expectation that the overall performance of the system should be at least 95%. The objective test results are derived from response time sending notifications on the mobile phone via Blynk Apps, as shown in Table I.

TABLE I. UNITS FOR MAGNETIC PROPERTIES

Attempt	Response Time (Second)			Average Response Time
	Envelope 1	Envelope 2	Envelope 3	
1	1.45	2.33	3.3	2.36
2	1.71	1.44	1.54	1.56
3	1.65	1.53	2.2	1.79
4	1.88	1.68	1.54	1.70
5	1.65	2.31	2.33	2.10
6	1.81	3.32	1.52	2.22
7	1.55	2.15	2.1	1.93
8	2	1.62	1.33	1.65
9	2.3	1.77	1.45	1.84
10	1.83	1.43	2.44	1.90

The data in Table I shows that the time taken for the notification system to alert the receiver or the user is just below 4 seconds and on average the response time is below 3 seconds. It is concluded that this system gives a short time notification to the receiver or user so that they are alert on the incoming letter or small parcel they received.

IV. CONCLUSION

This paper demonstrates how a smart mailbox notification system was successfully developed. This smart mailbox will assist consumers in reducing the loss of important documents or letters by notifying users via the Blynk App on their phones. The notification will tell users when a letter has been placed into the Smart Mailbox that requires them to be connected to Wi-Fi. Users of the Smart Mailbox will profit from this action or awareness because they will be notified on their cell phones if any documents are received at the present time. Furthermore, the testing went well, with notifications appearing on the "Blynk" device, as noted in the discussion section.

This project can be improved for improvement by adding a camera outside the mailbox where the users can see clearly if they actually lost any documents. However, a study needs to be done on how the camera can be placed and should be waterproof since the mailbox will be put outside the house. By putting a hidden camera, users can easily check on what happened to their documents if anything happened or if they lost it. With this development, it can give a positive and better life to the users.

REFERENCES

[1] C. Paul, A. Ganesh, and C. Sunitha, "An overview of IoT based smart homes," in *2018 2nd International Conference on Inventive Systems and*

- Control (ICISC)*, 2018, pp. 43-46. IEEE. Available: <https://ieeexplore.ieee.org/abstract/document/8398858>
- [2] Z. Zheng, "Home Automation: Smart home technology and template house design," Bachelor's thesis, Savonia University Of Applied Sciences, 2013. Available: <https://www.theseus.fi/handle/10024/62819>
- [3] K. Oliver, M. Herter, T. H. Khan (2020, May). An Architecture of a Touchscreen Operated Window Blinds for Smart Home. *Int. J. Eng. Sci. Invent.* pp. 34-39. Available: [http://www.ijesi.org/papers/Vol\(9\)i5/Series-2/G0905023439.pdf](http://www.ijesi.org/papers/Vol(9)i5/Series-2/G0905023439.pdf)
- [4] A. Hayes, "Smart Home: Definition, How They Work, Pros and Cons" September 2022. Available online: <https://www.investopedia.com/terms/s/smart-home.asp>
- [5] A. L. bin Mohd Rusli, W. N. W. Muhamad, S. S. Sarnin, & M. M. A. M. Hamzah, "A Low-Cost Smart Parcel Box System with Enhanced Security", The 2022 International Conference on Artificial Life and Robotics (ICAROB2022), January 20 to 23, 2022. Available online: <https://alife-robotics.co.jp/members2022/icarob/data/html/data/OS/OS32/OS32-8.pdf>
- [6] A. M. Abd Jalil, R. Mohamad, N. M. Anas, M. Kassim & S. I. Suliman, "Implementation of vehicle ventilation system using NodeMCU ESP8266 for remote monitoring," *Bulletin of Electrical Engineering and Informatics*, 10(1), pp. 327-336, February 2021.
- [7] J. MacKay, (2019, March). Screen time stats 2019: Here's how much you use your phone during the workday. *RescueTime*, March 2019. Available online: <https://blog.rescuetime.com/screen-time-stats-2018/>
- [8] J. Yang, F. Gu, J. Guo, and B. Chen (2019). Comparative life cycle assessment of mobile power banks with lithium-ion battery and lithium-ion polymer battery. *Sustainability*, 11(19), 5148. Available: <https://www.mdpi.com/2071-1050/11/19/5148>
- [9] Z. Hassan, "Smart Mailbox", Bachelor's thesis, Hame University of Applied Sciences, 2018. Available: <https://www.theseus.fi/bitstream/handle/10024/159920/Smart%20Mailbox.pdf?sequence=1&isAllowed=y>
- [10] J. A. C. O. B. Tunberg and J. Barriel, "The smart mailbox," Bachelor's thesis, KTH Royal Institute of Technology, Stockholm, 2020. Available: https://www.kth.se/polopoly_fs/1.987202.1589830463!/tunbergjacob_52111_2870370_The%20smart%20mailbox%20100-1.pdf
- [11] S. Turská, and L. Madleňáková, (2019). Concept of smart postal mailbox. *Transportation Research Procedia*, 40, pp. 1199-1207. Available: <https://www.sciencedirect.com/science/article/pii/S2352146519303357>
- [12] The Gate Smart Mailbox. Available online: <https://newatlas.com/gate-smart-mailbox/37408/> (accessed on 23 October 2023).
- [13] CC1120 High-Performance RF Transceiver for Narrowband Systems. Available online: <https://www.ti.com/lit/ds/symlink/cc1120.pdf> (accessed on 23 October 2023).
- [14] Postifier. Available online: <https://newatlas.com/postifier-postbox-notifications/28373/> (23 October 2023)
- [15] Mr. Postman. Available online: <https://www.engadget.com/2013-11-08-mr-postman-hands-on.html> (23 October 2023).