

Performance Analysis of Air Monitoring System Using 433 MHz LoRa Module

Abstract: The escalating air pollution issue has garnered significant public attention in recent years. This pervasive environmental challenge exerts a profound negative impact on living organisms and the ecosystem, posing a substantial threat to human health. Moreover, the existing works in air monitoring systems have a limited range and inability to identify specific pollutants. This issue can be solved by developing a real-time air quality monitoring system using the Internet of Things (IoT) and Long Range (LoRa) wireless technologies. This work addresses these issues through gas sensors and remote data collection. The system has been equipped with notification of AQI levels and types of gasses detected via email and the ThingSpeak platform. This work uses a series of gas sensors, MQ135, MQ7, MQ9 and Honeywell gas sensors, to measure the level of harmful gas such as ammonia, carbon monoxide gas, LPG gas, API, and dust particles. The data from the gas sensors is transmitted via LoRa, controlled by Arduino Nano and NodeMCU ESP8266 Wi-Fi module. Findings demonstrate that the proposed air monitoring system detected a higher AQI concentration, 185 ppm, at the Melaka Sentral parking area during peak hours. This reading is classified as unhealthy conditions for health.

Streszczenie: Eskalacja problemu zanieczyszczenia powietrza przyciągnęła w ostatnich latach znaczną uwagę opinii publicznej. To wszechobecne wyzwanie środowiskowe wywiera głęboki negatywny wpływ na żywe organizmy i ekosystem, stwarzając poważne zagrożenie dla zdrowia ludzkiego. Ponadto dotychczasowe prace w systemach monitoringu powietrza mają ograniczony zasięg i brak możliwości identyfikacji konkretnych zanieczyszczeń. Problem ten można rozwiązać, opracowując system monitorowania jakości powietrza w czasie rzeczywistym z wykorzystaniem technologii bezprzewodowych Internet of Things (IoT) i Long Range (LoRa). Ta praca rozwiązuje te problemy za pomocą czujników gazu i zdalnego gromadzenia danych. System został wyposażony w powiadamianie o poziomach AQI i rodzajach wykrytych gazów za pośrednictwem poczty elektronicznej oraz platformy ThingSpeak. W tej pracy wykorzystano serię czujników gazu, MQ135, MQ7, MQ9 i czujniki gazu Honeywell, do pomiaru poziomu szkodliwych gazów, takich jak amoniak, gazowy tlenek węgla, gaz LPG, API i cząstki pyłu. Dane z czujników gazu są przesyłane przez LoRa, sterowane przez Arduino Nano i moduł Wi-Fi NodeMCU ESP8266. Wyniki pokazują, że proponowany system monitorowania powietrza wykrył wyższe stężenie AQI, 185 ppm, na parkingu Melaka Sentral w godzinach szczytu. Odczyt ten jest klasyfikowany jako stan niezdrowy dla zdrowia. (Analiza wydajności systemu monitorowania powietrza z wykorzystaniem modułu LoRa 433 MHz)

Keywords: Air Quality Index, Air monitoring, Internet of Things (IoT), LoRa

Słowa kluczowe: Indeks Jakości Powietrza, Monitoring Powietrza, Internet Rzeczy (IoT), LoRa

Introduction

Nowadays, air quality in the surrounding is getting worse because of polluted smoke from cars, factories, and the environment [1]. Poor air quality harms human health, especially at night when our bodies take in clean air while we sleep. The polluted air can cause lung infections, such as asthma, a hacking cough, and other lung problems. People can't tell if the air is dirty by how they feel and don't know there could be many dangerous things, like LPG gas, smoke, carbon monoxide gas, and methane. Airborne contaminants pose a threat to human health. This examination enables us to identify pollutants in the air.

The Internet of Things (IoT) in many air monitoring systems allows data to be screened periodically via the internet and saved in the IoT cloud for air quality monitoring purposes. However, the IoT system can only establish a short-range communication link and sometimes interferes with data reception because of the internet connection. A Long-Range Radio (LoRa) technology that offers low-power and long-range wireless connectivity solves this issue. LoRa has the shortest delay or consumes the least energy for a given file size and distance and can be used to adaptively select the communication protocol to optimise network performance [2].

Previous research has shown that various devices are used for IoT connectivity. Devices that can connect to the Internet and other devices are necessary for the IoT system to succeed. Most work, such as [3-5], used ESP8266 Wi-Fi Module for connection. Some IoT system uses minicomputer that is costly for connectivity, such as Raspberry Pi [6] and Beagle bone [7].

As a direct consequence of this, an air monitoring system based on a LoRa communication system will be developed to improve the performance monitoring issues. The application of LoRa, specifically within the wireless

wide area network technologies category, can cover a significant distance. Moreover, LoRa is a low-power wide-area network (LPWAN) device. It can send data to our smart devices through the Internet of Things. This makes it possible to monitor the air quality without fail and from any location [8]. The system that is being proposed will create efficient monitoring of air quality for users, allowing them to read and analyse data regarding air quality.

Methodology

The design of this air monitoring system consists of two parts of the circuit which are the transmitter and receiver that communicate through LoRa SX1278 with a frequency of 433 MHz. The transmitter is a sensor node. Meanwhile, the receiver is a web application server. The block diagram of the system is shown in Fig. 1.

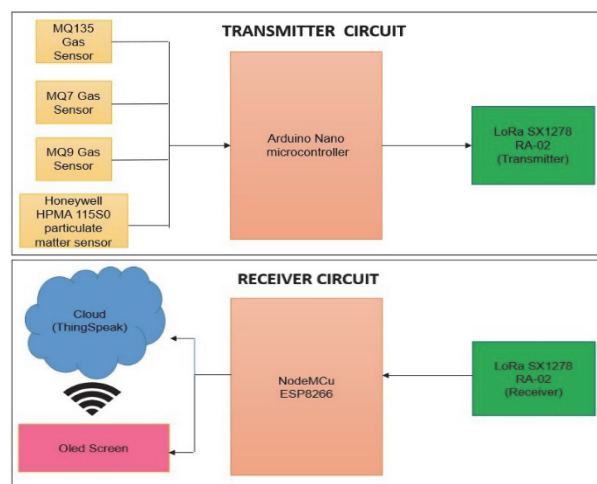

Fig.1. Functioning block diagram

A. Hardware development

Four types of sensors are installed on the sensor node: gas sensors MQ135, MQ9, MQ7 and HoneyWell HPMA 115S0. Gas sensors MQ135, MQ9, and MQ7 detect harmful gas such as ammonia, carbon monoxide, and LPG; meanwhile, HoneyWell HPMA 115S0 senses API and dust particles. Arduino Nano controls the sensors and transmits the data from these sensors via LoRa.

Then the data is stored in NodeMCU ESP8266 at the receiver part and displayed on ThingSpeak in either webpages or mobile applications. The system provides the reading of AQI and gas concentration data from sensors in a real-time.

The data sensor controlled by the Arduino Nano sends the data via the LoRa transmitter to the LoRa receiver. In the receiver circuit, the NodeMCU ESP8266 store data collected from the sensors in the IoT cloud and displays the monitoring data at Oled Screen and ThingSpeak.

The system's alert is triggered by a calibrated sensor, Honeywell HPMA 115S0, which determines each level of API from good to hazardous air quality and then sends it to the email every 30 minutes.

Gas Sensors

A series of gas sensors used in this work is shown in Fig.2. Sensors from the MQ 135 gas sensor family can be used in air quality control equipment to detect or measure harmful or poisonous gases that affect air quality, including Ammonia (NH3), Nitric oxide (NOx), Alcohol, Benzene, and carbon dioxide (CO2). Users can adjust the load resistance to calibrate the air quality by using the potentiometer on the sensor board.

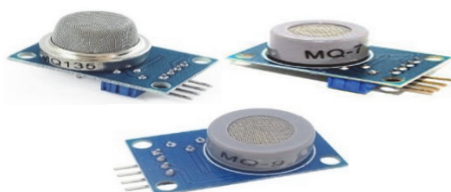

Fig.2. MQ135 gas sensor, MQ7 gas sensor, MQ9 gas sensor

The MQ-7 is one of the resistive chemical sensors that can detect graphene (SnO₂) and carbon monoxide (CO). This sensor could be used to detect different CO-containing gases, is inexpensive, and is suitable for various applications. Meanwhile, MQ 9 gas sensors are used in air monitoring systems to detect Liquefied Petroleum Gas (LPG) in devices that deal with this gas in factories and homes. The sensitive material of the MQ-9 gas sensor is SnO₂, which with lower conductivity in clean air. The sensor could be used to detect different gases containing CO. It is at a low cost and suitable for various applications.

The Honeywell HPM Series Particulate Matter Sensor, as shown in Fig. 3. is a laser-based sensor that uses light scattering to provide information on particle concentration for a given particle concentration range and Air Quality Index (AQI). The detection concentration range is between 0 and 1,000 g/m³. HoneyWell HPMA sensor is an excellent choice for an air monitoring system to trigger the Air Pollution Index's precise data for alert monitoring. The level of the Air Quality Index (AQI) is shown in Table 1.

Malaysia's air pollution comes from three main sources: Mobile, stationary, and open burning sources. Mobile sources, such as motor vehicles, contribute 70-75 % of total air pollution [9]. Stationary sources polluted between 20 and 25% of the air, while open burning sources and forest fires polluted between 3% and 5%. The Malaysian Air Quality Index (AQI) measures fine particles and gases such as carbon monoxide, sulphur dioxide, and nitrogen dioxide.

The Malaysian AQI standard can be viewed in [10] and Table 1.

Table 1. Air Quality Index (AQI) [11]

Level of health concern	AQI Concentration (PPM)
Good	0-50
Moderate	51-100
Unhealthy for sensitive groups	101-150
Unhealthy	151-200
Very unhealthy	201-300
Hazardous	>300



Fig.3.Honeywell HPMA 115S0

B. Software development

The schematic circuit for the transmitter and receiver was developed using Proteus 8 Professional, as shown in Fig. 4. The circuits have been tested to ensure they are suitable to achieve the desired result.

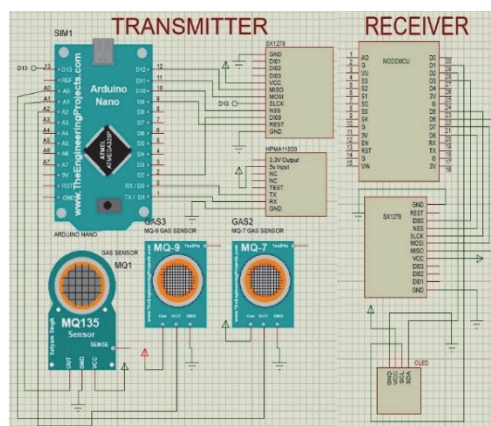

Fig. 4: Schematic circuit for transmitter and receiver develop in Proteus

ThingSpeak is an IoT analytics platform that aggregates, visualises, and analyses live data streams. Users can visualise data to ThingSpeak from their devices. ThingSpeak monitors the graph-level concentration of harmful gas such as ammonia, CO, AQI and dust particles in this work.

This software helps users to visualise live data in an analytic platform. The current condition of the gasses concentration in specific locations can be viewed on the ThingSpeak platform. ThingSpeak helps the air monitoring system operate efficiently by sending an API notification every 30 minutes to email.

C. Location Test Setting

A series of experiments and analyses were conducted using the air monitoring system. The measurement was done in Line of Sight (LOS) scenario, where both transmitter and receiver are placed 5-meter distances at each location. The system was tested for 12 hours at Parking Melaka Sentral and Pintu Belakang Universiti Teknikal Malaysia Melaka (UTeM Gate)

Parking Melaka Sentral is situated in the heart of Malacca town near Mydin Mall, as shown in Fig. 5(a). Most

of the vehicles may enter the parking space to park. These parking spaces are only for cars, vans, and motorcycles.

In the meantime, the location of the UTeM Gate is illustrated in Fig. 5(b). It is a one-lane road that is always congested by staff and students' vehicles during peak hours. The peak hours are between 8-9 am, 12-2 pm and 4-6 pm. UTeM buses also go through this entrance to fetch students to class.



Fig. 5 (a)

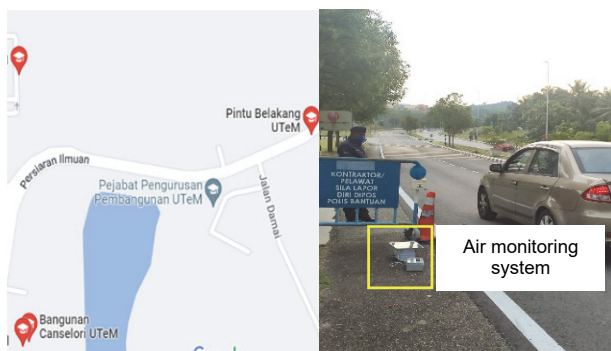

Fig.5 (b)

Fig. 5: Air monitoring system at (a) Parking Melaka Sentral and (b) UTeM Gate

Results and discussion

The prototype of the Air Monitoring System is shown in Fig. 6. and Fig.7. Fig. 6 illustrates the transmitter part that consists of gas sensors, Arduino Nano as a microcontroller and LoRa SX1278 to transmit data to the receiver part. Meanwhile, the receiver in Fig. 7 comprises LoRa SX1278 receiver, Node MCU ESP8266 Wi-Fi Module to push data to the ThinkSpeak cloud, and an OLED screen to display AQI data.

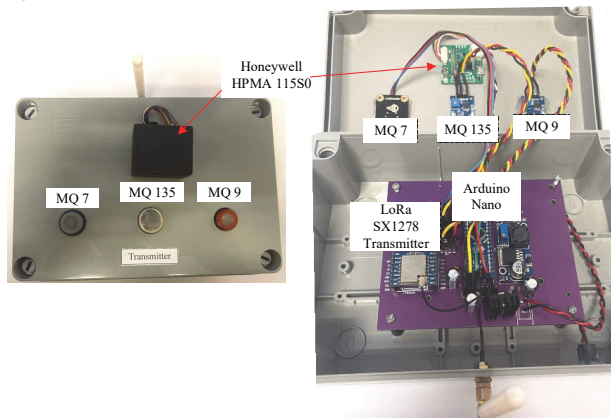

Fig. 6. Transmitter of Air Monitoring System

Measurement data obtained from two locations has been stored in the ThinkSpeak cloud. The gas

concentration and AQI can be viewed in the web-based or mobile application in real-time. The interface of this system is shown in Fig. 8 (a), which notify the status of AQI to alert the user. Besides, graphical data, as in Fig. 8(b) also displayed in the interface to show the changing trends in gas concentration and AQI level in real-time.

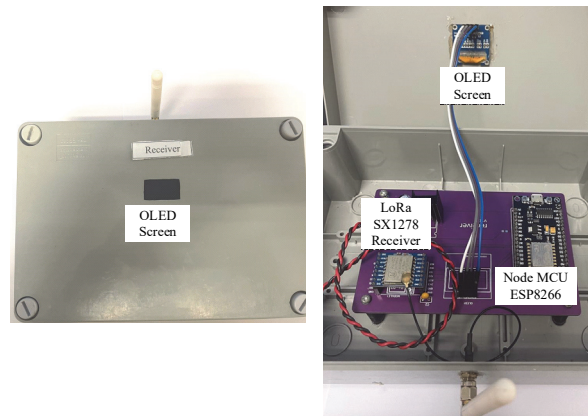

Fig.7. Receiver of Air Monitoring System

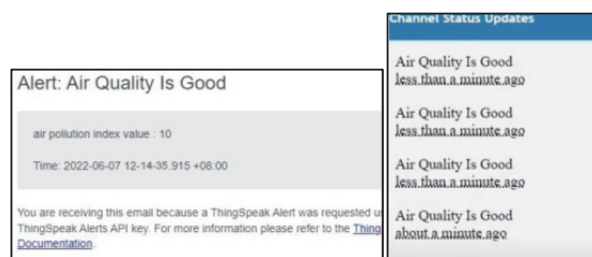

Fig. 8. (a)

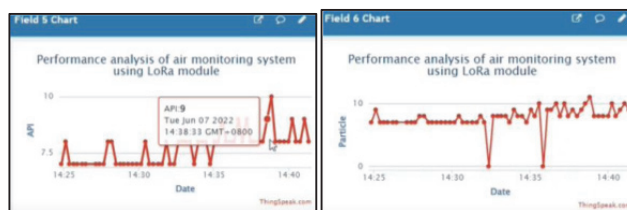

Fig. 8. Air monitoring system viewed in ThingSpeak: (a) AQI notification (b) graphical display (b)

Fig. 9 shows the detected gas from MQ9, MQ7 and MQ135 at two locations. Observation on 12 hours measurement in two locations displayed a fluctuation in the concentration of gasses as shown in Fig. 9. In Fig. 9(a), the LPG gas has been detected, and the highest concentration of the gas is at 16:35 in Parking Melaka Sentral. Meanwhile, for the location at UTeM gate, the LPG concentration is increased at certain times, such as 8:25 am, 10:30 am, 1:30 pm, and 6:30 pm.

This increasing trend happened due to two main reasons: staff vehicles going in and out of campus and the movement of UTeM's shuttle bus to Kampus Teknologi according to the established schedule. The same trend also applies to CO and harmful gas, as shown in Figures 9(b) and 9(c).

The Honeywell HPMA 115S0 sensor detects dust particles and AQI concentration in this work. From Fig. 10, 185 ppm AQI concentration was detected at Melaka Sentral at 3:55 pm. This is the highest concentration of AQI detected in the two locations. Meanwhile, in Fig. 11, 90 ppm dust particle concentration has been discovered at Melaka Sentral.

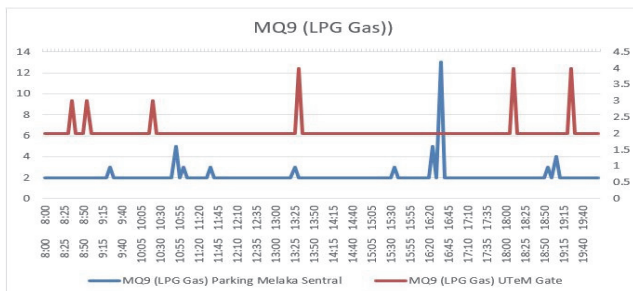

Fig.9 (a)

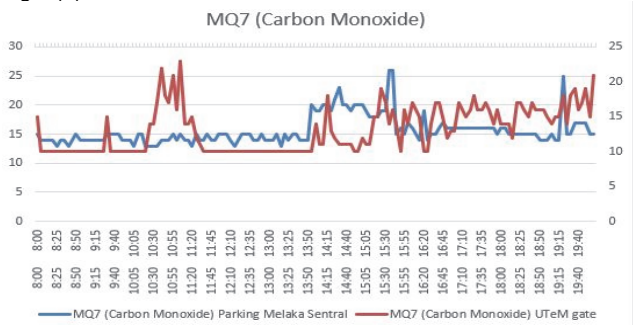

Fig. 9 (b)

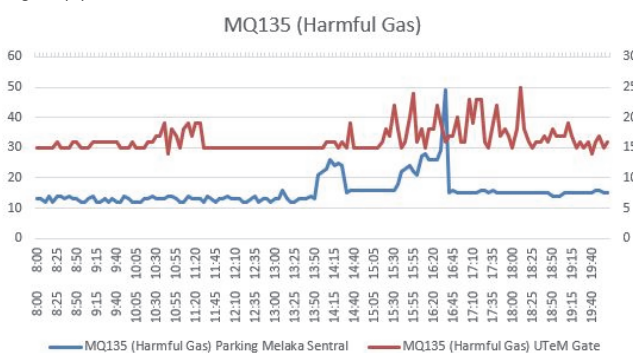

Fig. 9 (c)

Fig. 9 Detected gas from sensors: (a) MQ9, (b) MQ7, and (c) MQ135

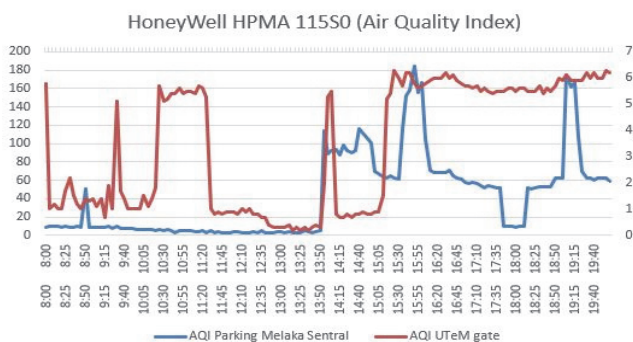

Fig. 10. AQI at Parking Melaka Sentral and UTeM gate

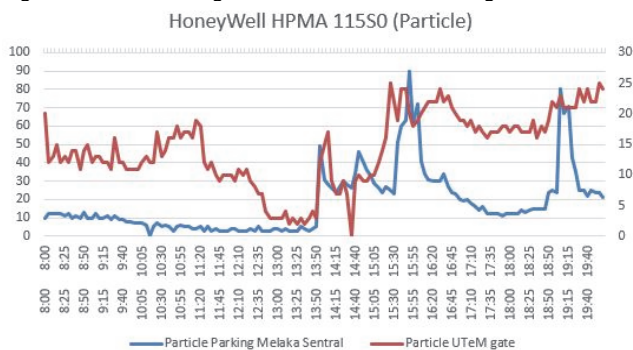

Fig. 11. Dust Particles at Parking Melaka Sentral and UTeM gate

Table 2 displays the gas sensors used in Air Monitoring System and the detected gas for each gas sensor. The highest gas concentration at the two locations also shows in the table. At Melaka Sentral, all gas concentrations detected are higher than the UTeM gate since it is located near the main road and can be accessed by the public for 24 hours. The AQI at Melaka Sentral is 185 ppm and is classified in unhealthy conditions.

Table 2. Type of Gas Sensors Used in Air Monitoring System

Type of gas sensor	Gas Detected	Higher gas concentration	
		Melaka Sentral	UTeM Gate
MQ135 gas sensor	Harmful gas such as ammonia gas, benzene and alcohol	49 ppm	25 ppm
MQ7 gas sensor	Carbon Monoxide gas	25 ppm	23 ppm
MQ9 gas sensor	LPG gas	13 ppm	4 ppm
HoneyWell HPMA115S0	Air Quality Index	185 ppm	65 ppm
	Dust particle	90 ppm	27 ppm

Conclusion

In conclusion, the air monitoring system can show results on harmful gas such as ammonia, carbon monoxide gas, LPG gas, Air Pollution Index (API), and Dust Particles at Parking Melaka Sentral and UTeM gate. It can be concluded that API at Melaka Sentral is higher than UTeM gate hour due to peak hour traffic.

ACKNOWLEDGEMENT

The authors are grateful to the CRIM and Universiti Teknikal Malaysia Melaka (UTeM) for the opportunity and support, including financial through relevant grants where applicable.

Authors

Mas Haslinda Mohamad, Centre for Telecommunication Research and Innovation (CeTRI), Fakulti Kejuruteraan Elektronik dan Kejuruteraan Komputer, Universiti Teknikal Malaysia Melaka, Hang Tuah Jaya, 76100 Durian Tunggal, Melaka, Malaysia. mashaslinda@utem.edu.my,
 Muhammad Khairul Naim Bin Abdul Rahim, Media City Development Sdn Bhd, Angkasapuri, Mediacity RTM, Bukit Putra, 59200 Kuala Lumpur. khairul.naim@klmediacity.com,
 Elfarizanis Baharudin, Department of Communication Engineering, Faculty Electrical and Electronic, Universiti Tun Hussien Onn Malaysia 86400 Parit Raja, Batu Pahat, Johor, Malaysia. elfa@uthm.edu.my,
 Mawarni Mohamed Yunus, Centre for Telecommunication Research and Innovation (CeTRI), Fakulti Kejuruteraan Elektronik dan Kejuruteraan Komputer, Universiti Teknikal Malaysia Melaka, Hang Tuah Jaya, 76100 Durian Tunggal, Melaka, Malaysia. mawar@utem.edu.my,

REFERENCES

- [1] M. A. Maruf, "The Effect of Movement Control Order During Covid19 Pandemic on Air Quality and Gas Emissions: A Review," JURNAL KESEHATAN LINGKUNGAN, vol. 12, no. 1si, pp. 51–59, Sep. 2020, doi: 10.20473/JKL.V12I1SI.2020.51-59
- [2] G. Klimiashvili, C. Tapparello, and W. Heinzelman, "LoRa vs. WiFi Ad Hoc: A Performance Analysis and Comparison," 2020 International Conference on Computing, Networking and Communications, ICNC 2020, pp. 654–660, Feb. 2020, doi: 10.1109/ICNC47757.2020.9049724.
- [3] Kumbalkar, G., et al., IoT Based Whether Reporting with Air and Sound Pollution Monitoring System, *International Journal for Research in Applied Science and Engineering Technology* 10 (2022), 372-375.

- [4] YUSOP, Azdiana, et al. "Development and Evaluation of Dual Axis Solar Tracking System with IoT Data Monitoring." *Przeład Elektrotechniczny* 99.1 (2023), 28-32.
- [5] SULAIMAN, Siti Fatimah, et al. "IoT-based monitoring system for hydroponics." *Przeład Elektrotechniczny* 2023.8 (2023), 135-140.
- [6] Simo, Attila, et al., Technical solution for a real-time air quality monitoring system, *International journal of computers communications & control* 15.4 (2020).
- [7] Desai, N.S. and Alex, J.S.T., IoT based air pollution monitoring and predictor system on Beagle bone black, *2017 International Conference on Nextgen Electronic Technologies: Silicon to Software (ICNETS2)*. IEEE, (2017),367-370.
- [8] M. Iqbal, A. Y. M. Abdullah, and F. Shabnam, "An Application Based Comparative Study of LPWAN Technologies for IoT Environment," 2020 IEEE Region 10 Symposium, TENSYP 2020, pp. 1857–1860, Jun. 2020, doi: 10.1109/TENSYP50017.2020.9230597.
- [9] Afroz, Rafia, Mohd Nasir Hassan, and Noor Akma Ibrahim. "Review of air pollution and health impacts in Malaysia." *Environmental research* 92.2 (2003): 71-77.
- [10] Wong, Kok-Seng, et al. "Toward forecasting future day air pollutant index in Malaysia." *The Journal of Supercomputing* 77 (2021): 4813-4830.
- [11] Air, I. Q. "World Air Quality Report. Region & City PM2. 5 Ranking. IQ Air, 2020." (2019).