

Design, Analysis and Fabrication of Chassis Frame for UTeM Formula Varsity™ Race Car

Mohd Azman. Abdullah, Muhd Ridzuan. Mansor, Musthafah. Mohd Tahir, Syahibudil Ikhwan. Abdul Kudus, Muhammad Zahir. Hassan and Mad Nasir. Ngadiman

Abstract—Two chassis frames of race car have been designed and developed according to the specifications of UTeM Formula Varsity™ 2012 (FV2012). FV2012 is an event to test students' analytical and technical skills in designing, analyzing and fabricating a race car. In this section of report, the design and development of the chassis frame of the race car are presented. Commercial computer aided design (CAD) software is used in design and analysis stages. Once the results of the analysis are desirable, actual chassis frame fabrication is performed using available materials. Standard processes of cuttings, fittings and welding are performed in chassis frame mock up and fabrication. The product is later assembled together with suspension systems, steering linkages, brake systems, engine system, and drive shaft systems. The accomplishment in final fittings and assembly of the race car and its reliability demonstrate an excellent design for manufacturing (DFM) practices of the chassis frame.

Keywords—Chassis and frame, formula varsity race car, chassis frame fabrication.

I. INTRODUCTION

SPACE frame chassis has been used widely in varsity level formula race car [1]. Due to its advantages of easy to be manufactured and easy to be repaired, space frame chassis is the most favorite choice for race car development of newly introduced varsity level race formula competition such as Universiti Teknikal Malaysia Melaka, (UTeM) Formula Varsity™ 2012 (FV2012). This Formula SAE and Formula Student-like race competition is initiated by UTeM since 2006 [2][3]. It tests the undergraduate students' analytical and technical skills in designing, analyzing and fabricating a race car.

This report summarizes the design, analyses and fabrication processes of the chassis frame. The end product is then used in actual assembly of the race car together with the other components. Due to some tolerances in fitting and welding processes, the final chassis frame is modified and changed slightly throughout the fabrication process.

II. CHASSIS DESIGN

The CATIA V5 R20 CAD software is used in the design

Mohd Azman. Abdullah, Muhd Ridzuan. Mansor, Musthafah. Mohd Tahir, Syahibudil Ikhwan. Abdul Kudus, Muhammad Zahir. Hassan and Mad Nasir. Ngadiman are with the Faculty of Mechanical Engineering, Universiti Teknikal Malaysia Melaka, Hang Tuah Jaya, 76100 Durian Tunggal, Melaka, Malaysia (phone: +606-2346845 ; fax: +6062346884 ; e-mail: mohdazman@utem.edu.my).

process of the chassis frame. Fig. 1 and Fig. 2 show the 3D model of the chassis frame design 1 and 2 respectively. The rib of 25 mm x 25 mm square with 1.6 mm thickness shape is used based on actual hot steel rod tube material available. Table I tabulates the general specifications of the chassis frame design.

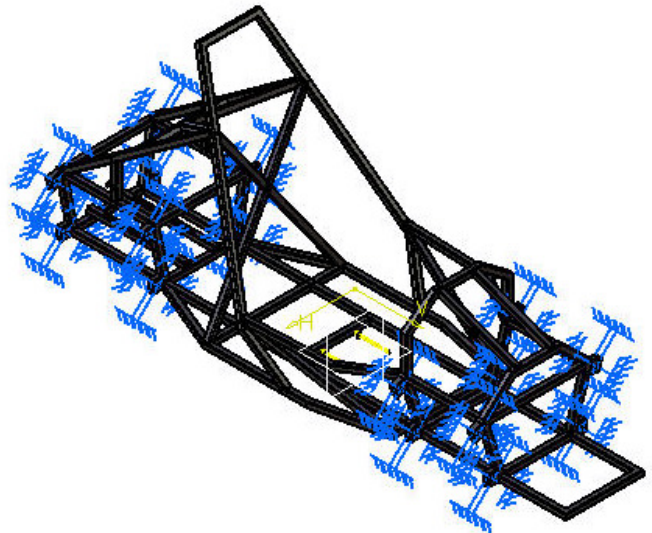

Fig. 1 3D model of the chassis frame design 1

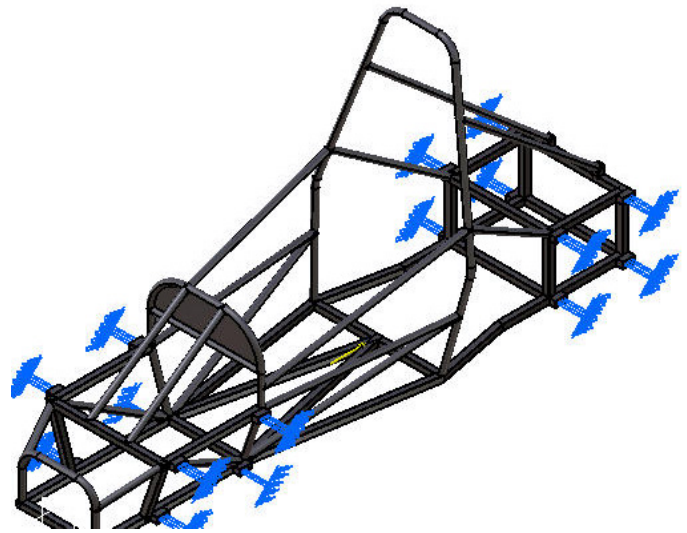

Fig. 2 3D model of the chassis frame design 2

TABLE I
 GENERAL SPECIFICATIONS

Parameter	Value	Unit
Wheel base	1700	mm
Track width	1114	mm
Ground clearance	160	mm

III. ANALYSIS

In the analysis stage, ASTM A500 Grade B hot roll steel square tube is used as the material of the frame. The force applied is 6000 N, which is three times of the maximum weight of the car excluding the weight of the driver. The analyses consist of acceleration loading test, bending test, brake test, torsion test and impact test. Table II summarizes the chassis specifications for the analysis.

TABLE II
 CHASSIS SPECIFICATIONS

Parameter	Value	Unit
Material	ASTM A500	
Kerb weight	165.33	kg
Mass	21.86	kg
Density	7850	kg/m ³
Volume	0.003	m ³
Young's Modulus	200	
Yield Strength	250 x 10 ⁶	Nm ²
Load	6000	N

IV. RESULTS AND DISCUSSIONS

Fig. 3 and Fig. 4 illustrate the example results of the simulation analysis of acceleration test for design 1 and 2 correspondingly. The factor of safety results are summarized in Table III. Based on the Von Mises stress value, the safety factor is calculated at the red spot of the stress contour. All analyses produced favorable factor of safety which is higher than 2.0. This shows that, the chassis frame design is ready for manufacturing.

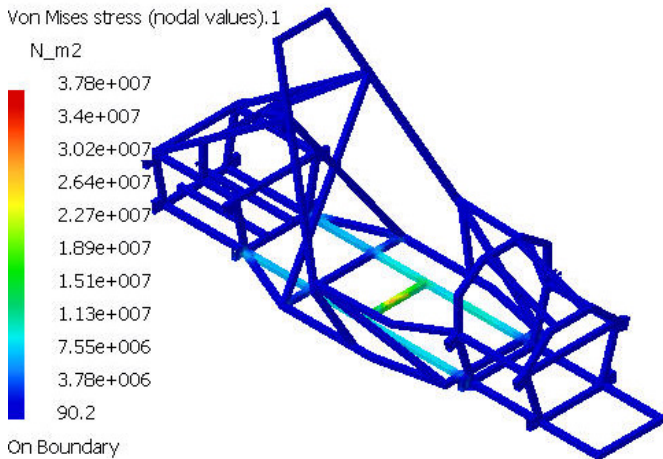

Fig. 3 Acceleration test design 1

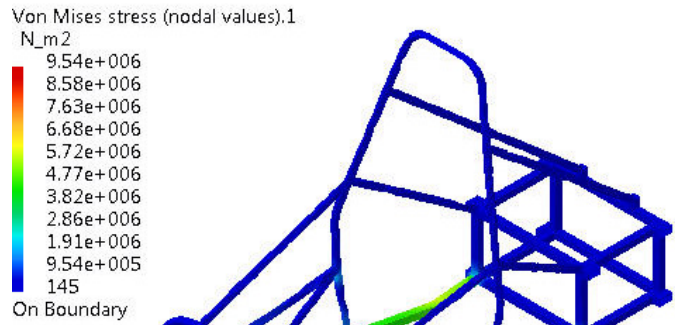

Fig. 4 Acceleration test design 2

TABLE III
 FACTOR OF SAFETY

Analysis	Design 1	Design 2
Acceleration	6.61	5.49
Bending	5.98	7.16
Braking	6.38	6.21
Torsion	2.51	2.25
Impact	4.07	4.34

V. CHASSIS FABRICATION

Both designs of the chassis are fabricated using available steel rods and square tubes. It involves material cutting, fitting and joint welding as shown by Fig. 5. Fig. 6 and Fig. 7 show the rolling chassis of design 1 and design 2 after assembly.

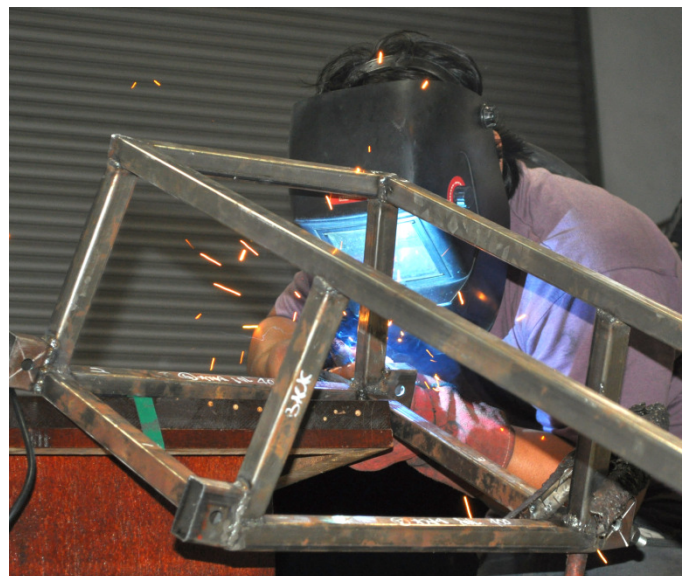

Fig. 5 Joint welding process of chassis fabrication



Fig. 6 Rolling chassis of design 1

Automotive and Motorsport Engineering from Brunel University, UK. He pursued and finished his doctorate study at Tokyo University of Agriculture and Engineering, Japan in Mechanical Control Systems in 2011. His expertise is in mechanical vibration and control system.



Fig. 7 Rolling chassis of design 2

VI. CONCLUSION

The simulation analysis results have established approving outcome in term of factor of safety at different loading tests. The final products for both designs have been fabricated successfully and verified the practice of design for manufacture (DFM). The fitting and assembly of the rolling chassis have verified the accuracy and acceptable tolerance in design and fabrication.

ACKNOWLEDGMENT

The authors gratefully acknowledged the financial support from Universiti Teknikal Malaysia Melaka under short term grant: PJP/2012/FKM(1C)/S01001.

REFERENCES

- [1] Milliken, William F. and Milliken, Douglas L., "Race Car Vehicle Dynamics", SAE, 1997.
- [2] 2012 Formula SAE Competition Rules and Regulations, SAE International, 2012.
- [3] Formula Varsity 2012 Competition Rules and Regulations, UTeM, 2012.

Mohd Azman Abdullah is a senior lecturer at the Faculty of Mechanical Engineering, Universiti Teknikal Malaysia Melaka, Malaysia. He graduated from Universiti Tenaga Nasional, Malaysia in Bachelor in Mechanical Engineering in 2002. In 2005, he finished his Master of Science in