

# Development of Fuzzy Logic Water Bath Temperature Controller using MATLAB

Norhaslinda Hasim

Department of Control and Automation, Faculty of  
Electrical Engineering, Universiti Teknikal Malaysia  
Melaka, Hang Tuah Jaya, 76100 Durian Tunggal, Melaka,  
Malaysia.  
norhaslinda@utem.edu.my

Mohd Shahrriel Mohd Aras

Department of Mechatronics, Faculty of Electrical  
Engineering, Universiti Teknikal Malaysia Melaka, Hang  
Tuah Jaya, 76100 Durian Tunggal, Melaka, Malaysia.  
shahrriel@utem.edu.my

Mohd Zamzuri Ab Rashid

Department of Mechatronics, Faculty of Electrical  
Engineering, Universiti Teknikal Malaysia Melaka, Hang  
Tuah Jaya, 76100 Durian Tunggal, Melaka, Malaysia.  
zamzuri@utem.edu.my

Anuar Mohamed Kassim

Department of Mechatronics, Faculty of Electrical  
Engineering, Universiti Teknikal Malaysia Melaka, Hang  
Tuah Jaya, 76100 Durian Tunggal, Melaka, Malaysia.  
anuar@utem.edu.my

Dr Shahrum Shah Abdullah

Department of Electric and Electronics,  
Malaysia-Japan International Institute of Technology,  
Universiti Teknologi Malaysia, International Campus Jalan Semarak,  
54100 Kuala Lumpur, Malaysia  
shahrum@ic.utm.my

**Abstract**— In this paper, the development of a water bath temperature system to control the liquid's temperature in the water bath will be presented. In order to develop the water bath temperature control system, MATLAB fuzzy logic toolbox will be utilized. The Fuzzy Logic Controller (FLC) is designed to control water temperature based on the input acquired from the thermal transducer sensor. The inference engines that are used are; Max-min (Mamdani) method and centre of gravity technique for defuzzification. The 4 x 4 matrix rules for the controller will be used in this project. In addition, the USB NI-DAQ card will be used as xPC target to link the MATLAB software and real time application. The real time output temperature is validated based on the simulation's temperature which is initially set by user. It can be concluded the performance of real time study is in par with the simulation result.

**Index Terms**- Temperature Control; fuzzy logic controller; Water bath System

## I. INTRODUCTION

Water baths are used in industrial clinical laboratories, academic facilities, government research laboratories environmental applications as well as food technology and wastewater plants[1][3-5]. Because water retains heat so well, using water baths was one of the very first means of incubation. Applications of water bath include sample thawing, bacteriological examinations, warming reagents; coli form determinations and microbiological assays [6][10- 11].

The first thing to consider when purchasing a water bath is the electronics part. Digital control systems provide greater temperature uniformity, stability and control. Constant temperature digital water baths are suited to a host of applications, including bacteriological examinations, food processing/QC procedures and microbiology assays, just to name a few [9].

In this paper, the system will be designed using MATLAB fuzzy logic toolbox for a fuzzy logic control system based on temperature (water) to output the temperature of water bath. When the water level in water tank is full, the heater should turn to the highest temperature. The level sensor on the water bath not implemented yet and using manual to control the level of water in the water bath system. The schematics of water bath control system shown in Figure 1.

The design of this system will mainly based on assumption of initial water temperature and the initial amount of water. The output of the water bath temperature is based on people's need. It is also depends on the surrounding temperature whether it has a cold surrounding or hot temperature. Therefore, the objective of this system is to control the water bath temperature according to the needs of people.

This paper is organized as follows. Section 1 and 2 describe brief introduction of water bath system. Section 3 describes simulation results using the MATLAB software and hardware implementation with field testing results. Finally, section 4 shows the final remarks.

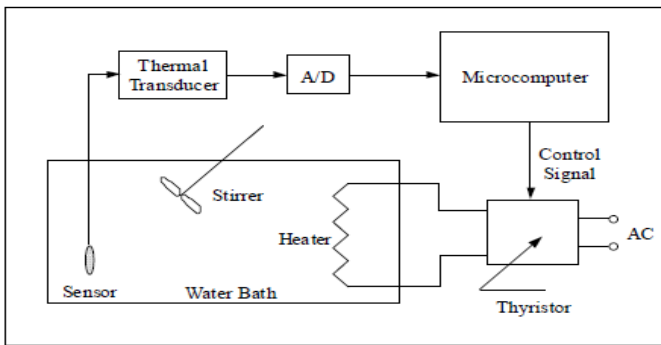

Figure 1: Schematic of water bath control system

## II WATER BATH SYTEM

The primary objective of this project is to setup a water bath, interfacing system and the server in the lab located in University Teknikal Malaysia Melaka. The water bath consists of the water tank itself, a temperature sensor (RTD), a heater and a stirrer[1]. An interface system will also be mounted so that the water bath can be controlled through the server computer using the GUI module developed. The development of GUI module can be referred to [1]. Figure 2 shows the water bath wiring system.

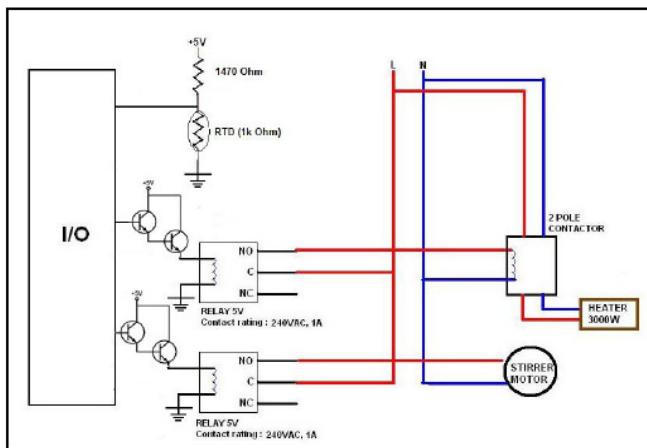

Figure 2: Water bath wiring system

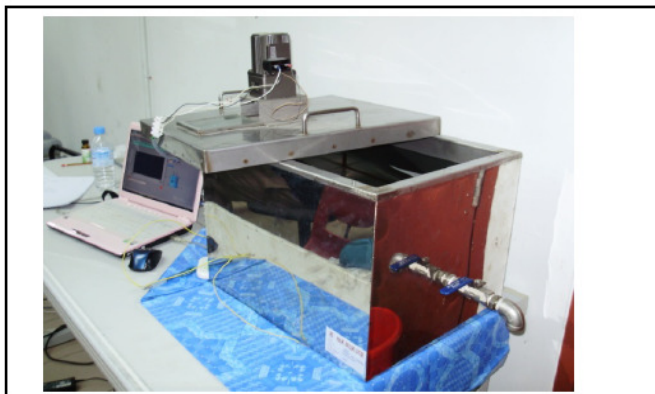

Figure 3: Complete of Water bath System



Figure 4: Motor 12V for stirrer



Figure 5: Controller module using USB NI-DAQ card



Figure 6: Inside of water bath system (Sensor, Heater and Stirrer).

The complete system of water bath system are shown in Figure 3 until Figure 6. Figure 3 shows the complete system of water bath while Figure 4, 6 shows the components of water bath system. Figure 5 shows the control and data acquisition card using NI DAQ 6009.

## III SYSTEM DESIGN CONCEPT

This system will be design using MATLAB fuzzy tools using FIS (Fuzzy Inference System) and M-file in this paper. The design on the MATLAB itself is using the FLC (Fuzzy Logic Controller) to exert a block diagram based on the problem.

### A. Main Idea FLC

In this section, the main ideas underlying the FLC will be presented. To highlight the issues involved, Figure 7 shows the basic configuration of an FLC, which comprises four principal components: a *fuzzification interface*, a *knowledge base*, *decision making logic*, and a *defuzzification interface*. [2]

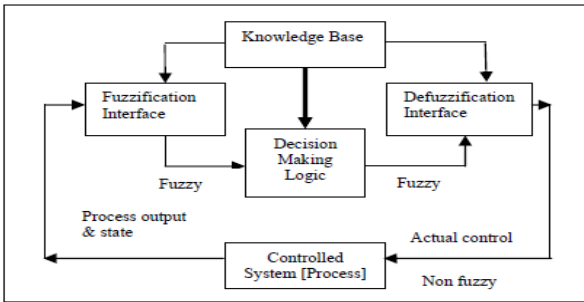

Figure 7: Block diagram for Fuzzy Logic Architecture

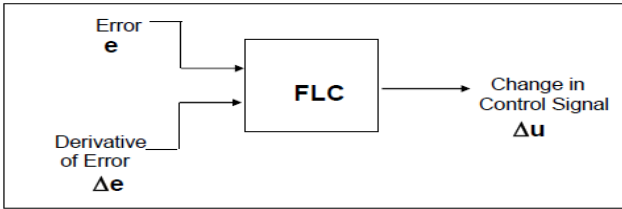

Figure 8: Block Diagram of system design concept

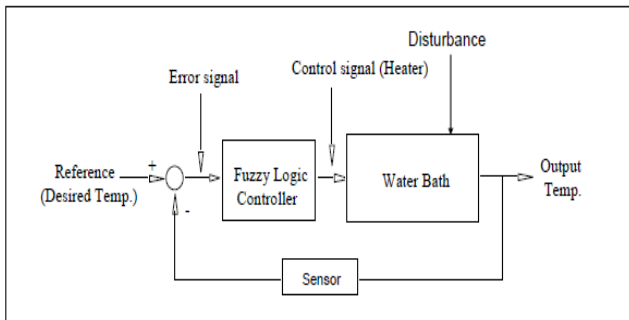
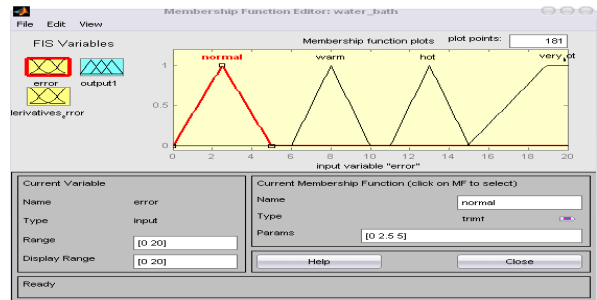

Figure 9: Block diagram of the water bath temperature control system

There are two inputs and single output will be design in FLC system as shown in Figure 8. The inputs is the error and the change of error while the output is the change in control signal. The main idea is highlighted in Figure 9. The FLC system will be implemented on water bath system through Fig 9.

#### IV DESIGN METHODOLOGY

Input 1 is the error (temperature). It will divided into 3 triangular membership functions and 1 trapezium membership function which named as normal, warm, hot and very hot. Input 2 is the change of error (water level in the tank) into 4 triangular membership functions as well which named as low, medium, high and very high. This 2 inputs will output a triangle membership function which is the control signal (water temperature of a water bath). The output is divided into 4 membership functions as well which are normal, warm, hot, and very hot. This system will be using Mamdani inference engine. There will be 16 rules applied between input 1 and input 2. The rules that will be includes in the system are shown in Figure 11.



(a) Input variable - error temperature

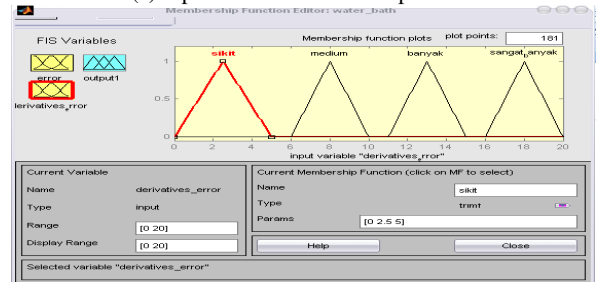

(b) Input variable - change of error

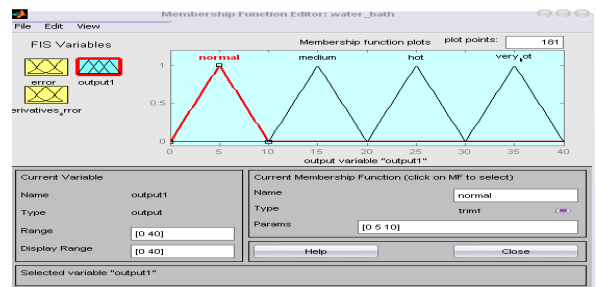

(c) Output Variable

Figure 10: Input and output membership functions

	error	normal	warm	hot	very_hot
derivatives_error					
low		N	M	H	VH
medium		N	N	M	H
high		N	N	N	M
very_high		N	N	N	N

Figure 11: Rules Matrix

From Figure 10, the input and the output is designed in triangular membership function and no overlap between them. This is because the system is more accurate and no doubtful when defuzzification is applied.

## V. ALTERNATIVE DESIGN TECHNIQUE

### A. MATLAB M-File

Other than using MATLAB GUI (graphic user interface) which is FIS, MATLAB also able to create a fuzzy logic controller using M-file which coding is only what needed in this method and its will all result after debugging the M-file. However, the result is the same as using MATLAB GUI but this design method is slow compare to FIS.

### B. Labview Software

The block diagram of the water-bath control system for this project is shown in Figure 12. The desired temperature can be selected by key in the desired values. In addition, the current temperature can be monitored through the indicator shown. The response between the set point and process variable can be monitored in the waveform graph. Figure 13 shows the rule base for the control system. From the Rulebase Editor front panel, the defuzzification method and inference method can be selected. In this case, Center of Gravity defuzzification and Max-min inference method are chosen.

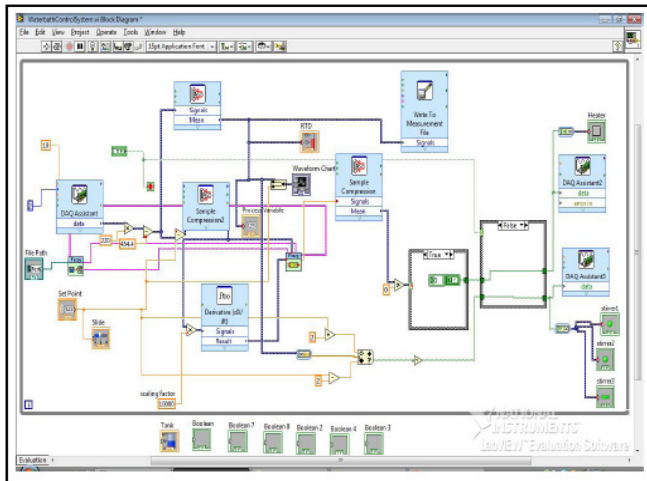

Figure 12: Labview Software

Rule-Nbr	IF Error	IF Rate of Error	THEN out	With DoS
1	NE1	NE2	OFF	1.00
2	NE1	ZE2	OFF	1.00
3	NE1	PO2	OFF	1.00
4	ZE1	NE2	OFF	1.00
5	ZE1	ZE2	ZE0	1.00
6	ZE1	PO2	ON	1.00
7	PO1	NE2	ON	1.00
8	PO1	ZE2	ON	1.00
9	PO1	PO2	ON	1.00

Figure 13: Rules based set up on LabView

## VI. RESULT

The expected result of the whole system can be simplified and categorized as the following table;

Table 1: Summarize the system expected result

Very hot	31 – 40
Hot	21 – 30
Warm	11 – 20
Normal	0 - 10

Output (Water Temperature)

Table 2: Rules for Output

Input 1 \ Input 2	0 – 5 (Normal)	6 – 10 (Warm)	11 – 15 (Hot)	16 – 20 (Very hot)
0 – 5 (Low)	0 - 10	11 – 20	21 - 30	31 - 40
6 – 10 (Medium)	0 - 10	0 - 10	11 – 20	21 - 30
11 – 15 (High)	0 - 10	0 - 10	0 - 10	11 – 20
16 – 20 (Very High)	0 - 10	0 - 10	0 - 10	0 - 10

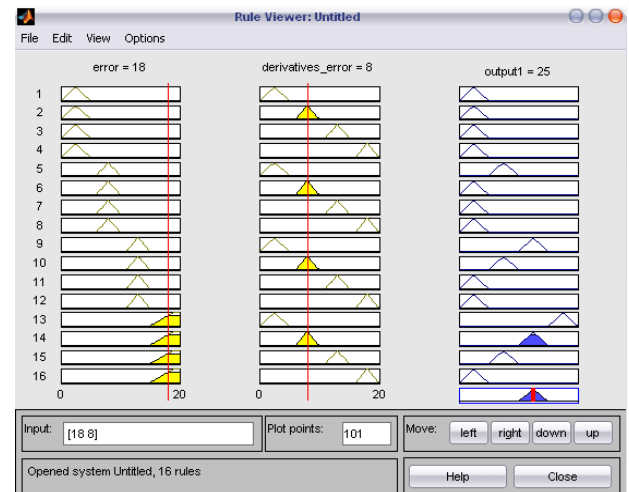

Figure 14: Rules and result of the system on MATLAB rules viewer.

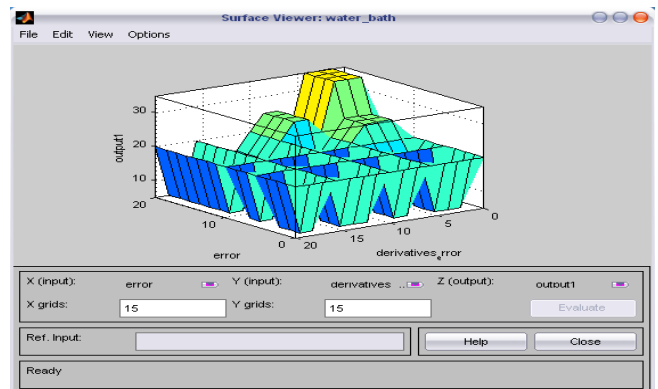

Figure 15: Surface viewer of the system.

The summary of rules and result can be output in MATLAB rules view of the FIS tools. The overall of the result can be shown in surface viewer of MATLAB surface viewer. The waveform signal when the set point was 50°C is depicted in Figure 16. The figure shows temperature versus number of data taken during the experiment. From the waveform, it can be seen that the initial temperature was a room temperature which is 30°C. After the set point was set to 50°C, the fuzzy controller is trying to reach the set point and after 24 minutes, the desired temperature is achieved.

Figure 17 shows the signal waveform when the process set point was 40°C. After five minutes the system reaches its set point, then the user change the set point to 60°C. From 40°C to 60°C, generally, it takes about 10 to 15 minutes to the system to achieve its new set point. Set point of 70°C and 80°C were set, and the waveform is as depicted in Figure 18. Initially the temperature inside the water bath was 60°C. But after the set point is set to 70°C, the fuzzy controller tries to reach 70°C and it can be clearly seen that the readings is stagnant for a while after it achieves 70°C. Then, when the set point was changed to 80°C, the fuzzy controller was then again tries to achieve it and it goes stagnant once the desired temperature is achieved.

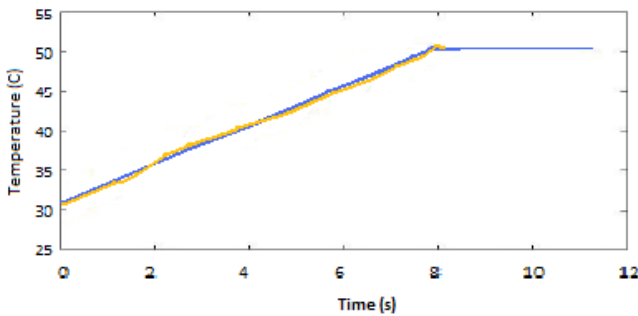

Figure 16: Waveform when setpoint 50 °C

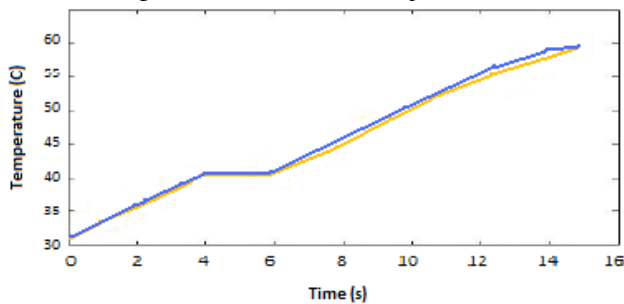

Figure 17: Waveform when setpoint 40 °C

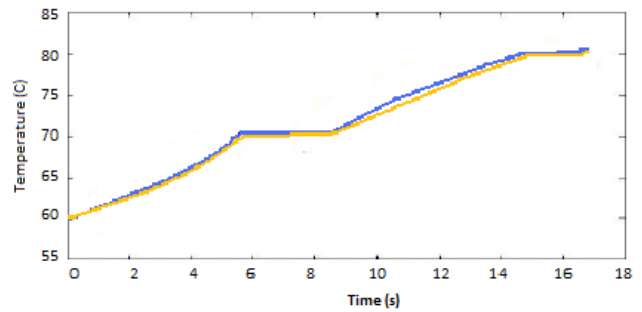

Figure 18: Waveform when setpoint 70 °C

## VII. SUMMARY

Overall, this paper describes water bath temperature control system development by using FLC. This system is produced through MATLAB software and 16 rules are utilized to obtain the optimized result for the system. From the observation, it is shown that the outputs for the control system are depended to the input that has been initially declared. Last but not least, the FLC controller is easily programmed and can be implemented to make the system achieves more accurate result and saves the energy of the water bath system.

In the next development, this FLC controller scheme can be compared with other controller such as PID controller, Neuro-fuzzy controller, Neural- Network controller, Sliding Mode controller and adaptive controller and the comparison are done through the experimental studies. By conducting comparison studies between these controllers, it is hoped that a robust controller can be acquired to control this water bath control system.

## ACKNOWLEDGEMENT

Special appreciation and gratitude to honorable University (UniversitiTeknikal Malaysia Melaka, UTeM and UniversitiTeknologi Malaysia, UTM) especially to the both Faculty of Electrical Engineering for providing the financial as well as moral support to complete this project successfully

## REFERENCES

- [1] N. Hasim, M.F. Basar, M. S. Aras, Design and Development of a Water Bath Control System : A Virtual Laboratory Environment, 2011 IEEE Student Conference on Research and Development (SCoReD 2011)
- [2] M.S.M Aras, Salim SNS, Razak, I.A.W.A, Hairi H., Eric C.S.H, Comparison of Fuzzy Control Rules Using MATLAB Toolbox and Simulink for DC Induction Motor-Speed Control, International Conference of Soft Computing and Pattern Recognition (SCOPAR 2009)
- [3] M.Khalid and S. Omatu, "A neural network controller for a temperature control system" *IEEE Control Systems*, vol 12, pp 58-64, June 1992
- [4] P.Melba Mary, N.S.Marimuthu and Albert Singh, Design Of Intelligent Self-Tuning Temperature Controller For Water Bath Process, *International Journal Of Imaging Science And Engineering (Ijise)* pp. 121-124, Vol.1,No.4, October 2007

- [5] B. Claudia, F. Cesare, R. Riccardo, *International Summer School on Fuzzy Logic Control: Advance in Methodology*, Singapore: World Scientific, 1998.
- [6] K. Shimojima, T. Fukuda, and Y. Hasegawa, "Self-tuning fuzzy modeling with adaptive membership function, rules, and hierarchical structure based on genetic algorithm," *Fuzzy Sets Syst.*, vol. 71, pp. 295–309, 1995.
- [7] Teo Lian Seng, Marzuki Bin Khalid, "Tuning of a Neuro-Fuzzy Controller by Genetic Algorithm, IEEE Transactions On Systems, Man, And Cybernetics—Part B: Cybernetics, Vol. 29, No. 2, April 1999.
- [8] Mamdani E.H. Application of Fuzzy Logic to Approximate Reasoning Using Linguistic Systems. *IEEE Transaction on Computer*, C-26:1182–1183, 1977.
- [9] G.F. Franklin, "Digital Control of Dynamic Systems," Addison-Westley Publishing, c1990.
- [10] James G. Dawson, Zhiqiang Gao and Thomas A. Trautzsch, A Stable Self-Tuning Fuzzy Logic Control System for Industrial Temperature Regulation
- [11] Euan Lindsay, Dikai Liu, Steve Murray and David Lowe, "Remote Laboratories in Engineering Education: Trends in Students' Perceptions", Proceedings of the 2007 AaeE Conference, Melbourne.
- [12] V. Ramakrishnan, Y. Zhuang, S.Y. Hu, J.P. Chen, C.C. Ko, B.M. Chen and K.C. Tan, "Development of a Web-Based Laboratory for Control Experiments on a Coupled Tank Apparatus", Proceedings of the 2000 American Control Conference, Vol. 6 pp. 4409 - 4413.
- [13] C.C. Ko, B.M. Chen, S.H. Chen, V. Ramakrishnan, R. Chen, S.Y. Hu, Y. Zhuang, "A Large Scale Web-Based Virtual Oscilloscope Laboratory Experiment", Engineering Science & Education Journal, in press.
- [14] S.H. Chen, R. Chen, V. Ramakrishnan, S.Y. Hu, Y. Zhuang, C.C. Ko, B.M. Chen, "Development of Remote Laboratory Experimentation through Internet", Proceedings of the 1999 IEEE Hong Kong Symposium on Robotics and Control, Hong Kong, Volume II, pp.756 - 760, July 1999.
- [15] Hartmut Ewald and George F. Page, "Performing Experiments by Remote Control Using the Internet", Global J. of Engineering Education, Vol. 4, No.3, Australia.
- [16] Miladin Stefanovic, Vladimir Cvijetkovic, Milan Matijevic and Visnja Simic' "A LabVIEW-Based Remote Laboratory Experiments for Control Engineering Education", 2009 Wiley Periodicals, Inc.
- [17] Sanjit Das, L. N. Sharma and A. K. Gogoi, "Remote CommunicationEngineering through Internet", International Journal on Online Engineering, 2006.