

# High Gain of Cascode LNA at 5.8GHz Using T-Matching Network for wireless Applications

Ibrahim A.B, Husain M.N, Othman A.R, Johal M.S  
Faculty of Electronic and Computer Engineering  
Universiti Teknikal Malaysia Melaka  
[abupsp@gmail.com](mailto:abupsp@gmail.com), [rani@utem.edu.my](mailto:rani@utem.edu.my)

## Abstract

This paper presents a design of high gain single stage cascode low noise amplifier (LNA), which operates at 5.8GHz frequency for WiMAX application. The LNA design used T-Matching network consisting of lump reactive element at input and output matching. The design simulation process is using Advance Design System (ADS) software. A cascode low noise amplifier (LNA) produced gain of 19.52dB and noise figure (NF) at 1.195dB. The input reflection ( $S_{11}$ ) and output return loss ( $S_{22}$ ) are -18.86dB and -19.49dB respectively. The bandwidth of the amplifier is more than 1GHz. The input sensitivity is complying with the IEEE 802.16 standards. The LNA used FHX76LP low noise SuperHEMT FET transistor from Eudyna Inc.

*Keywords: Cascode LNA, WiMAX, Radio Frequency, T-Matching Network*

## I. Introduction

Recently, the market of wireless communication system is growing rapidly. Owing to market demands, there exist various wireless communication systems blooming for different frequency bands and different application. WiMAX, which is short for Worldwide Interoperability for Microwave Access, is a novel wireless communication technology. It is an attractive technology due to the high transmitting speed (up to 70Mbps) and long transmitting distance (up to 30 mile). The system bases on IEEE 802.16 standards and uses several bands (2.3-2.7 GHz, 3.4-3.6 GHz and 5.1-5.8GHz) to transmit data. The design of the front-end low noise amplifier (LNA) is one of the challenges in radio frequency (RF) receivers, which needs to provide good input impedance match, enough power gain and low noise figure (NF) within the required band [1].

Many high gain amplifier topologies have been proposed as a way to satisfy the requirement for low power dissipation as well as good performances. The cascode topology is results in a higher gain, due to the increase in the output impedance, as well as better isolation between the input and output ports. [2-6]. In this work, a single cascode LNA topology is proposed.

## II. Theoretical

Basically, for the design of an amplifier, the input and output matching network are designed to achieve the required stability, small signal gain, and bandwidth. Super high frequency amplifier is a typical active circuit used to amplify the amplitude of RF signal. Basic concept and consideration in design of super high frequency amplifier is presented below. For the LNA designed, the formula and equation were referred to [3]. Figure 1, shows a typical single-stage amplifier including input/output matching networks.

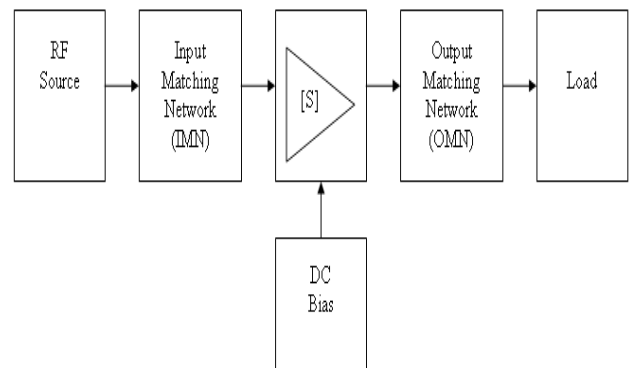

**Figure 1:** Typical amplifier designed

The basic concept of high frequency amplifier design is to match input/output of a transistor at high frequencies using S parameters frequency characteristics at a specific DC-bias point with source impedance and load impedance. I/O matching circuit is essential to reduce unwanted reflection of signal and to improve efficiency of transmission from source to load [3-4].

### A. Power Gain

Several power gains were defined in order to understand operation of super high frequency amplifier, as shown in Figure 2, power gains of 2 port circuit network with power impedance or load impedance at power amplifier represented with scattering coefficient are classified into Operating Power Gain, Transducer Power Gain and Available Power Gain [3-4].

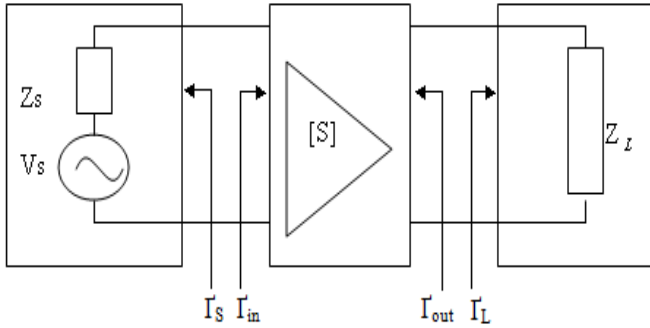

Figure 2: I/O circuit of 2-port network

### B. Operating Power Gain

Operating power gain is the ratio of power ( $P_L$ ) delivered to the load ( $Z_L$ ) to power ( $P_{in}$ ) supplied to 2 port network. Power delivered to the load is the difference between the power reflected at the output port and the input power, and power supplied to 2-port network is the difference between the input power at the input port and the reflected power. Therefore, Operating Power Gain is represented by

$$G_P = \frac{\text{Power delivered to the load}}{\text{power supplied to the amplifier}} = \frac{P_L}{P_{in}} = \frac{1}{1-|\Gamma_{in}|^2} |S_{21}|^2 \frac{1-|\Gamma_L|^2}{|1-S_{22}\Gamma_L|^2} \quad (1)$$

Where,  $\Gamma_{in}$  indicates reflection coefficient of load at the input port of 2-port network and  $\Gamma_s$  is reflection coefficient of power supplied to the input port.

### C. Transducer Power Gain

Transducer Power Gain is the ratio of  $P_{avs}$ , maximum power available from source to  $P_L$ , power delivered to the load. As maximum power is obtained when input impedance of circuit network is equal to conjugate complex number of power impedance, if  $\Gamma_{in} = \Gamma_s^*$ , transducer power gain is represented by

$$G_T = \frac{\text{Power delivered to the load}}{\text{Power Available from the source}} = \frac{P_L}{P_{avs}} = \frac{|S_{21}|^2 (1-|\Gamma_s|^2)(1-|\Gamma_L|^2)}{|(1-S_{11}\Gamma_s)(1-S_{22}\Gamma_L) - (S_{12}S_{21}\Gamma_s\Gamma_L)|^2} \quad (2)$$

Where,  $\Gamma_L$  indicates load reflection coefficient.

### D. Available Power Gain

Available Power Gain,  $G_A$  is the ratio of  $P_{avs}$ , power available from the source, to  $P_{avn}$ , power available from 2-port network, that is,  $G_A = \frac{P_{avn}}{P_{avs}}$ . Power gain is  $P_{avn}$  when  $\Gamma_{in} = \Gamma_s^*$ . Therefore Available Power Gain is given by:

$$G_A = \frac{\text{Power available from the amplifier}}{\text{Power available from the source}} = \frac{P_{avn}}{P_{avs}} = \frac{1-|\Gamma_s|^2}{|1-S_{11}\Gamma_s|^2} |S_{21}|^2 \frac{1}{|1-S_{22}\Gamma_L|^2} \quad (3)$$

That is, the above formula indicates power gain when input and output are matched [4].

### E. Noise Figure

Signals and noises applied to the input port of amplifier were amplified by the gain of the amplifier and noise of amplifier itself is added to the output. Therefore, SNR (Signal to Noise Ratio) of the output port is smaller than that of the input port. The ratio of SNR of input port to that of output port is referred to as noise figure and is larger than 1 dB. Typically, noise figure of 2-port transistor has a minimum value at the specified admittance given by formula:

$$F = F_{\min} + \frac{R_N}{G_S} |Y_s - Y_{opt}|^2 \quad (4)$$

For low noise transistors, manufactures usually provide  $F_{\min}$ ,  $R_N$ ,  $Y_{opt}$  by frequencies.  $N$  defined by formula for desired noise figure:

$$N = \frac{|\Gamma_s - \Gamma_{opt}|^2}{1 - |\Gamma_s|^2} = \frac{F - F_{\min}}{4R_N/Z_0} |1 + \Gamma_{opt}|^2 \quad (5)$$

### F. Condition for Matching

The scattering coefficients of transistor were determined. The only flexibility permitted to the designer is the input/output matching circuit. The input circuit should match to the source and the output circuit should match to the load in order to deliver maximum power to the load. After stability of active device is determined, input/output matching circuits should be designed so that reflection coefficient of each port can be correlated with conjugate complex number as given below [5]:

$$\Gamma_{IN} = \Gamma_S^* = S_{11} + \frac{S_{12}S_{21}\Gamma_L}{1 - S_{22}\Gamma_L} \quad (6)$$

$$\Gamma_{OUT} = \Gamma_L^* = S_{22} + \frac{S_{12}S_{21}\Gamma_S}{1 - S_{11}\Gamma_S} \quad (7)$$

The noise figure of the first stage of the receiver overrules noise figure of the whole system. To get minimum noise figure using transistor, power reflection coefficient should

match with  $\Gamma_{opt}$  and load reflection coefficient should match with  $\Gamma_{out}^*$

$$\Gamma_s = \Gamma_{opt} \quad (8)$$

$$\Gamma_L = \Gamma_{out}^* = \left( S_{22} + \frac{S_{12}S_{21}\Gamma_s}{1 - S_{11}\Gamma_s} \right) \quad (9)$$

## III. Design of LNA

The cascode LNA was design based on the S-parameter were obtained from calculation and simulation process using ADS. The s-parameter of a cascode LNA shown in a Table 1.

Table 1: S-Parameter for LNA

	S <sub>11</sub>	S <sub>12</sub>	S <sub>21</sub>	S <sub>22</sub>
5.8GHz	0.715	0.055	4.307	0.404
Angle	-82.739	43.240	87.684	-49.997

The overall performance of the LNA is determined by calculating the transducer gain  $G_T$ , noise figure  $F$  and the input and output standing wave ratios,  $VSWR_{IN}$  and  $VSWR_{OUT}$ . The optimum,  $\Gamma_{opt}$  and  $\Gamma_L$  were obtained as  $\Gamma_{opt} = 17.949 + j48.881$  and  $\Gamma_L = 79.913 - j7.304$ .

The complete schematic of the 5.8GHz a cascode low noise amplifier is shown in figure 3. Gate and drain of transistor M1 being shorted with  $L_6 = 1.18\text{nH}$  acting as shunt-peaking structure to enhance gain and bandwidth [7]. Source of Transistor M2 was inserted with inductor  $L_5 = 0.072\text{nH}$ , it is called inductive source degeneration. The values of passive elements in the input matching network are  $L_1 = 1288\text{nH}$ ,  $L_2 = 2.88\text{nH}$  and  $C_1 = 0.321\text{pF}$  and the values of passive elements in the output matching are  $L_3 = 481\text{pH}$ ,  $L_4 = 2.919\text{nH}$  and  $C_5 = 0.321\text{pF}$ . Parameters  $L_7 = 1.445\text{nH}$ ,  $L_8 = 2.74\text{nH}$ ,  $C_4$  and  $C_5 = 1\text{pF}$  act as a bias network. Capacitors  $C_1 = 0.815\text{pF}$ ,  $C_3 = 1.5\text{pF}$ ,  $C_6 = 1.4\text{pF}$  and  $C_7 = 0.386\text{pF}$  act as dc block. From simulation, it was recorded that the amplifier gain  $S_{21}$  was 19.52 dB. The input insertion loss  $S_{11}$  was -18.86dB, overall noise figure (NF) was 1.195dB and the output insertion loss  $S_{22}$  was -19.49dB. The reflected loss  $S_{12}$  was -22.10dB. These

values were within the design specification and were accepted.

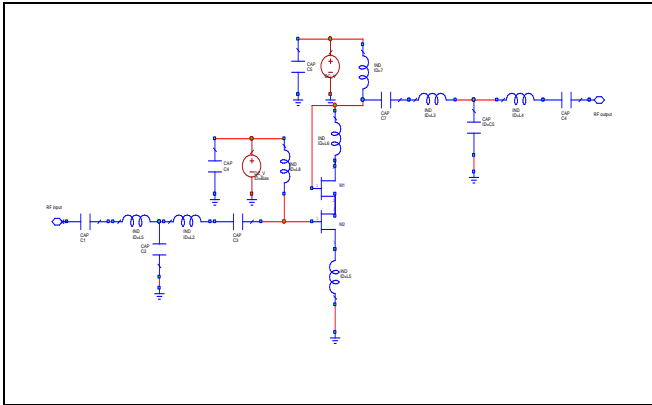

Figure 3: Complete schematic of the 5.8GHz LNA

#### IV. Simulation of Results

The Figure 3(a) is shows a graph of input insertion loss  $S_{11}$  and output insertion loss  $S_{22}$  while; Figure 3(b) is shows a graph of forward gain  $S_{21}$  and reflection loss  $S_{12}$ . Graph 3(c) and 3(d) are shows the stability and noise figure respectively. It is simulated using Advanced Design System software as well as tuning for the optimum noise figure and gain. The resultant of s-parameters is shown in Table 2. The comparison and lists of performances cascode LNA shown in Table 3.

Table 2: S-Parameter after matching process

Freq/dB	$S_{11}$	$S_{12}$	$S_{21}$	$S_{22}$	NF	(K)
5.8GHz	-18.86	-22.10	19.52	-19.49	1.195	1.016

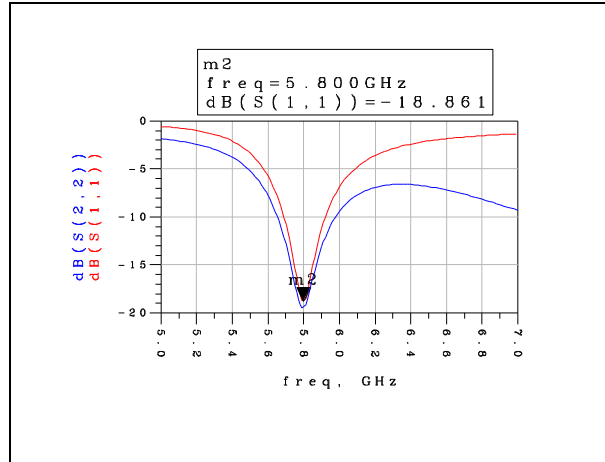

Figure 3(a):  $S_{11}$  and  $S_{22}$

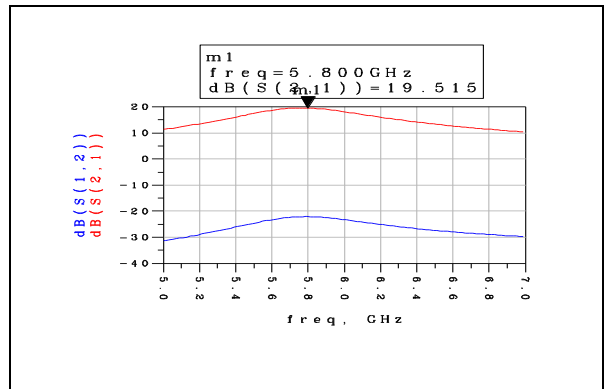

Figure 3(b):  $S_{21}$  and  $S_{12}$

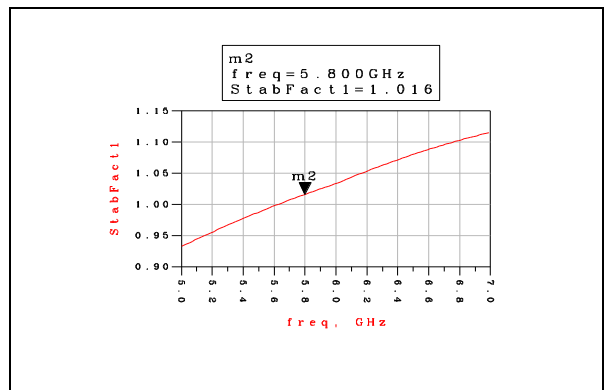

Figure 3(c): Stability of LNA

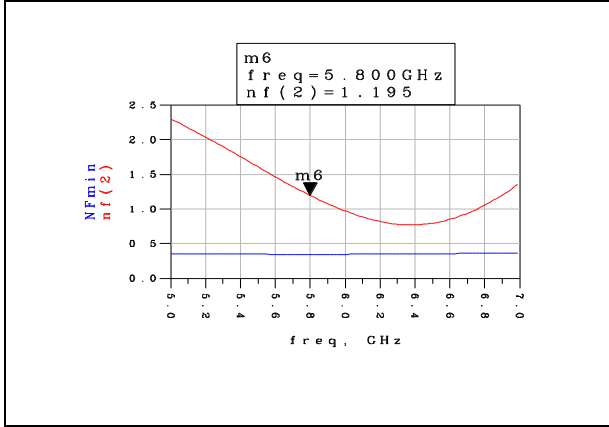

Figure 3(d): Noise Figure (NF)

## V. Conclusions

This paper presents a 5.8GHz LNA design and simulation using Advance Simulation System (ADS) software. The design was tuned using optimization tools in ADS such that the final design was improved in both gain and noise figure. The cascode topology was chosen for this design as it offers improved gain, reverses isolation and reduces the miller effect. The cascode amplifier used FHX76LP Low Noise SuperHEMT FET transistor from Eudyna Inc. At 5.8GHz, this LNA was recorded that the amplifier gain  $S_{21}$  was 19.52 dB. The input insertion loss  $S_{11}$  was -18.86dB and the output insertion loss  $S_{22}$  was -19.49dB. The reflected loss  $S_{12}$  was -22.10dB. The stability (K) and noise figure (NF) was 1.016dB and 1.195 dB respectively.

Table 3: Comparison of recently cascode LNA

Item/authors	[This work]	[1]	[2]	[8]
Technology	SuperHEMT	0.18um CMOS	90nm	GaAs pHEMT
Freq	5.8GHz	2-6GHz	5.8GHz	5.5GHz
Gain ( $S_{21}$ )	19.5dB	13.5	13.8	11dB
NF	1.2dB	2.7-4.5	1.7	1.6dB
$S_{11}$	-18.9dB	<-9	-	-9.2
$S_{22}$	-20dB	<-9	-	-8

## REFERENCES

- [1] Ruey-Lue Wang, Shih-Chih Chen, Cheng-Lin Huang, Chien-Hsuan Lie, Yi-Shu Lin. "2-6GHz Current-reused LNA With Transformer-type Inductors." IEEE 2008.
- [2] Leon, Michael Angelo G. Lorenzo and Maria Theresa G. De. "Comparison of LNA Topology for Wimax Application in a Standard 90-nm CMOS Process." *12th International Conference on Computer Modelling and Simulation*. 2010. pp-642-647.
- [3] M. Pozar, David. *Microwave and RF Wireless System*. Third Avenue, N.Y. John Wiley & Sons, in, 2001.
- [4] Gonzalez, Guillermo. *Microwave Transistor Amplifier*. 1996.
- [5] Othman A.R, Hamidon A.H, Ting J.T.H and Mustaffa M.F. "High Gain Cascaded Low Noise Amplifier Using T-Matching Network." 4<sup>th</sup> ISBC 2010.
- [6] Weber, Wuezhan Wang and Robert. "Design of a CMOS Low Noise Amplifier (LNA) at 5.8GHz and its Sensitivity Analysis." 11<sup>th</sup> NASA Symposium 2003.
- [7] Dorafshan and M. Soleimani. "High gain CMOS Low Noise Amplifier for Ultra Wide-Band Wireless Receiver." *Progress in Electromagnetic Research C*, Vol.7, PP-183-191, 2009
- [8] Arjuna Maruki, Norhapizan, and Amiza Rasmi. "GaAs PHEM Cascode LNA for Wireless Application". *International Journal of Computer and Electrical Engineering*, vol 1, 2009, pp-1793-8163.