

# Active Suspension using Optimal Controller

Norsarizan Mat Youb \* Mohd Ruddin Abd. Ghani \*\* Hamzah Sakidin \*\*\*  
Syed Najib Syed Salim \*\*\*\*

\* Universiti Teknikal Malaysia Melaka, Malaysia. Email: ijan\_nmy@yahoo.com

\*\* Universiti Teknikal Malaysia Melaka, Malaysia. Email: dpdruddin@utem.edu.my

\*\*\* Universiti Teknikal Malaysia Melaka, Malaysia. Email: hamzahsakidin@utem.edu.my

\*\*\*\* Universiti Teknikal Malaysia Melaka, Malaysia. Email: syednajib@utem.edu.my

**Abstract**—The purpose of the project is to design controller for active suspension using optimal control method. In order to reach the main objective, the behavior of passive suspension is studied correspond to the different types of road surface. The controller will improve the ride quality and handling performance within a given suspension stroke limitation. The problems of passive control are excessive vertical wheel travel, non-optimum altitude of tire relative to road, also the force distribution of the suspension, resulting poor handling, body roll or body pitch when braking or accelerating and ride discomfort. This problem will be overcome by using active control suspension which the method chosen is optimal controller. The performance of this controller is determined by performing computer simulations using the MATLAB and SIMULINK. The results show that the active suspension system has reduced the peak overshoot of sprung mass displacement, sprung mass acceleration, suspension travel and tire deflection compared to passive suspension system.

**Keywords**—Active suspension; Optimal Controller; Matlab and Simulink.

## I. INTRODUCTION

The vehicle suspension models are divided into three types which can be categorized as quarter car, half car and full car models. The quarter car model is based on the interaction between the quarter car body and the single wheel. The motion of the quarter car model is only in the vertical direction and for the half car model; the interactions are between the car body and the wheel and also between both ends of the car body. The first interaction in the half car models caused the vertical motion and the second interaction produced an angular motion. In full car model, the interactions are between the car body and the four wheels that generated the vertical motion, between the car body and the left and right wheels that generated an angular motion called rolling and between the car body and the front and rear wheels that produced the pitch motion [1].

For the past few decades, intelligent suspension systems have come into commercial use, especially in the passenger car industry. These modern systems offer improved comfort and road holding in varying driving and loading conditions compared to the matching properties achieved with traditional passive means. Most of the new systems are fitted in to large luxurious cars. However,

these systems would be at their most advantages in small size passenger cars and off-road vehicles [2].

An automotive suspension system is the mechanism that physically separates the car body from the car wheels. The main functions of vehicle suspension system are to minimize the vertical acceleration transmitted to the passengers to provide ride Comfort and to maintain the tire-road contact to provide holding characteristic, and to keep the suspension travel (rattle space) small. The suspension system is classified as a passive, semi active and active suspension system, according to its ability to add or extract energy. The passive suspension has no means of adding external energy to the system because it contains only passive elements such as a damper and a spring. Therefore its rates and forces can't be varied by external signals. Since technology was in progress, the active suspension idea has been suggested in 1960s [2].

Active suspension can supply energy from an external source and generate force to achieve the desired performance. However, Active suspension systems need some equipment making them very expensive. Another suspension system is semi active suspension system. Although the semi-active suspension, as the passive suspension, has no force actuator, it is possible to continuously vary the rate of energy dissipation using a controllable damper, but it is impossible to add energy [2].

### A. Proportional Integral Sliding Mode Approach

In the previous modeling, it is difficult to represent the motion equation into the state space form if more than one highest degree of differential variable occurred in the motion equation. This new technique is capable to overcome such situation and been discussed for a control scheme that will improve further the ride comfort and road handling of the active suspension system. The control scheme differs from the previous sliding mode techniques in the sense that the sliding surface is based on the proportional-integral sliding mode control (PISMC) strategy.

The additional integral in the proposed sliding surface provides one more degree of freedom and also reduce the steady state error. In the conventional sliding mode, the sliding mode gain is determined solely by the desired closed loop poles. Therefore the sliding surface is fully dependent on the sliding mode gain. In the PISMC, the sliding surface gain is determined by the desired closed

loop gain and the design parameter that can be adjusted to fulfill the sliding surface requirement.[1]

**B. Fuzzy Reasoning and Disturbance Observer**

The one-wheel car model to be treated here can be approximately described as a nonlinear two degrees of freedom system subject to excitation from a road profile. The active control is designed as the fuzzy control inferred by using single input rule modules fuzzy reasoning, and the active control force is released by actuating a pneumatic actuator. The excitation from the road profile is estimated by using a disturbance observer, and the estimate is denoted as one of the variables in the precondition part of the fuzzy control rules. A compensator is inserted to counter the performance degradation due to the delay of the pneumatic actuator. [3]

**C. PID controller Method**

The PID controller design deals with the selection of proportional, derivative gain and integral gain parameters ( $K_p$ ,  $K_i$ , and  $K_d$ ). PID controller is a common feedback loop component in industrial control systems. The difference (or "error" signal) is then used to adjust some input to the process in order to bring the process measured value back to its desired set-point. PID controllers do not require advanced mathematics to design and can be easily adjusted or tuned to the desired application, unlike more complicated control algorithms based on optimal control theory.[4]

**II. SUSPENSION MODEL**

**A. Passive Suspension Model**

Traditionally automotive suspension designs have been a compromise between the three conflicting criteria of road holding, load carrying and passenger comfort. The suspension system must support the vehicle, provide directional control during handling maneuvers and provide effective isolation of passengers/payload from road disturbances. In addition, a passive suspension system has the ability to store energy via a spring and to dissipate it via a damper. Its parameters are generally fixed, being chosen to achieve a certain level of compromise between road holding, load carrying and comfort[5]. The work presented here tries to analyze the effect of seat suspension on vehicle performance of a quarter car model for a given road input using different approaches namely analysis by using state space equations in MATLAB, analysis by equation of motion using mathematical blocks available in Simulink. Consider a passive suspension system of a quarter car model as shown in Figure 1 below:

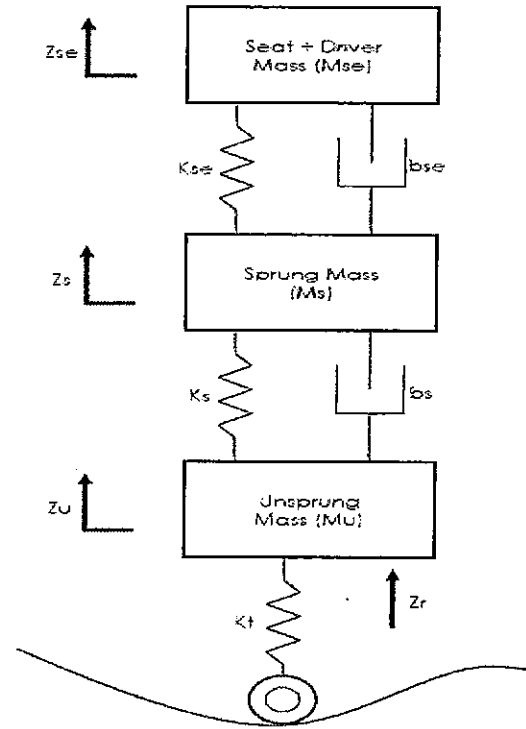

Figure 1: Quarter car model of passive suspension system

**B. Quarter model of Passive Suspension System**

The governing equations of the quarter car suspension system in Figure 1 are presented. The free body diagram for the car model is shown in Figure 2

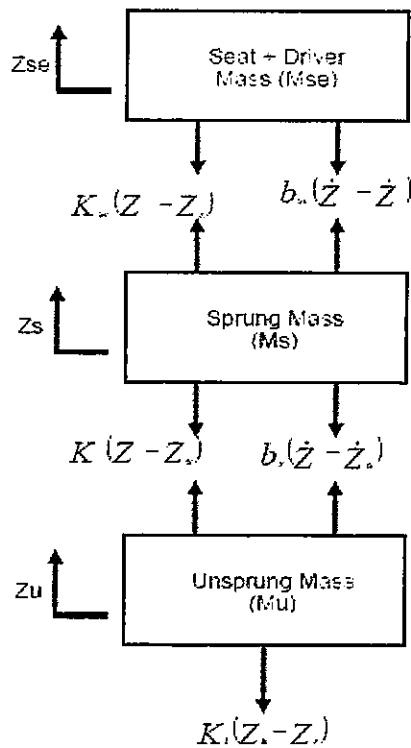

Figure 2 :The free body diagram for the car model

C. *Mathematical equation of the free body diagram*

Equation of motion from Figure 2 for drive and seat mass is given as below :

$$M_{se} \ddot{Z}_{se} + K_{se} (Z_{se} - Z_s) + b_{se} (\dot{Z}_{se} - \dot{Z}_s) = 0$$

or

$$\ddot{Z}_{se} = -K_{se} (Z_{se} - Z_s) / M_{se} - b_{se} (\dot{Z}_{se} - \dot{Z}_s) / M_{se} \quad (1)$$

Equation of motion for sprung mass as Figure 2 :

$$M_s \ddot{Z}_s - K_{se} (Z_{se} - Z_s) - b_{se} (\dot{Z}_{se} - \dot{Z}_s) + K_s (Z_s - Z_u) + b_s (\dot{Z}_s - \dot{Z}_u) = 0$$

or

$$\ddot{Z}_s = K_{se} (Z_{se} - Z_s) / M_s - b_{se} (\dot{Z}_{se} - \dot{Z}_s) / M_s + K_s (Z_s - Z_u) / M_s + b_s (\dot{Z}_s - \dot{Z}_u) / M_s \quad (2)$$

Equation of motion for unsprung mass as Figure 2 :

$$M_u \ddot{Z}_u - K_s (Z_s - Z_u) - b_s (\dot{Z}_s - \dot{Z}_u) + K_t (Z_u - Z_r) = 0$$

Or

$$\ddot{Z}_u = K_s (Z_s - Z_u) / M_u + b_s (\dot{Z}_s - \dot{Z}_u) / M_u - K_t (Z_u - Z_r) / M_u \quad (3)$$

D. *State space equation*

Based on mathematical equation of the free body diagram, assume space variable are as below:

$$\begin{aligned} x_1 &= \dot{Z}_{se} \\ x_2 &= Z_s - Z_{se} \\ x_3 &= \dot{Z}_s \\ x_4 &= Z_u - Z_s \\ x_5 &= \dot{Z}_u \\ x_6 &= Z_r - Z_u \end{aligned} \quad (4)$$

Substituting these space variables in equation 1, equation 2 and equation 3, the space state equation can be written

$$\begin{bmatrix} \dot{x}_1 \\ \dot{x}_2 \\ \dot{x}_3 \\ \dot{x}_4 \\ \dot{x}_5 \\ \dot{x}_6 \end{bmatrix} = \begin{bmatrix} 0 & 1 & 0 & 0 & 0 & 0 \\ \frac{K_{se}}{M_{se}} & \frac{b_{se}}{M_{se}} & \frac{K_{se}}{M_{se}} & \frac{b_{se}}{M_{se}} & 0 & 0 \\ 0 & 0 & 0 & 1 & 0 & 0 \\ \frac{K_{se}}{M_s} & \frac{b_{se}}{M_s} & \frac{K_s}{M_s} & \frac{K_s}{M_s} & 0 & \frac{K_s}{M_s} \\ 0 & 0 & 0 & 0 & 0 & \frac{1}{M_s} \\ 0 & 0 & \frac{K_s}{M_u} & \frac{b_s}{M_u} & \frac{K_t}{M_u} & \frac{K_t}{M_u} \end{bmatrix} \begin{bmatrix} x_1 \\ x_2 \\ x_3 \\ x_4 \\ x_5 \\ x_6 \end{bmatrix} + \begin{bmatrix} 0 \\ 0 \\ 0 \\ 0 \\ 0 \\ \frac{K_t}{M_u} \end{bmatrix} \quad (5)$$

Using equation 4, output equation for displacement and velocity output equation can be derived as

$$Y = \begin{bmatrix} Z_{se} \\ Z_s \\ Z_u \\ \dot{Z}_{se} \\ \dot{Z}_s \\ \dot{Z}_u \end{bmatrix} = \begin{bmatrix} 1 & 0 & 0 & 0 & 0 & 0 \\ 0 & 0 & 1 & 0 & 0 & 0 \\ 0 & 0 & 0 & 0 & 1 & 0 \\ 0 & 0 & 0 & 0 & 0 & 0 \\ 0 & 0 & 0 & 1 & 0 & 0 \\ 0 & 0 & 0 & 0 & 0 & 1 \end{bmatrix} \quad (6)$$

The suspension model system in Figure 3 is been designed in MATLAB/SIMULINK by using the equation 1, equation 2, and equation 3. The model consists of the three main parts which are driver and seat mass, sprung mass and unsprung mass.

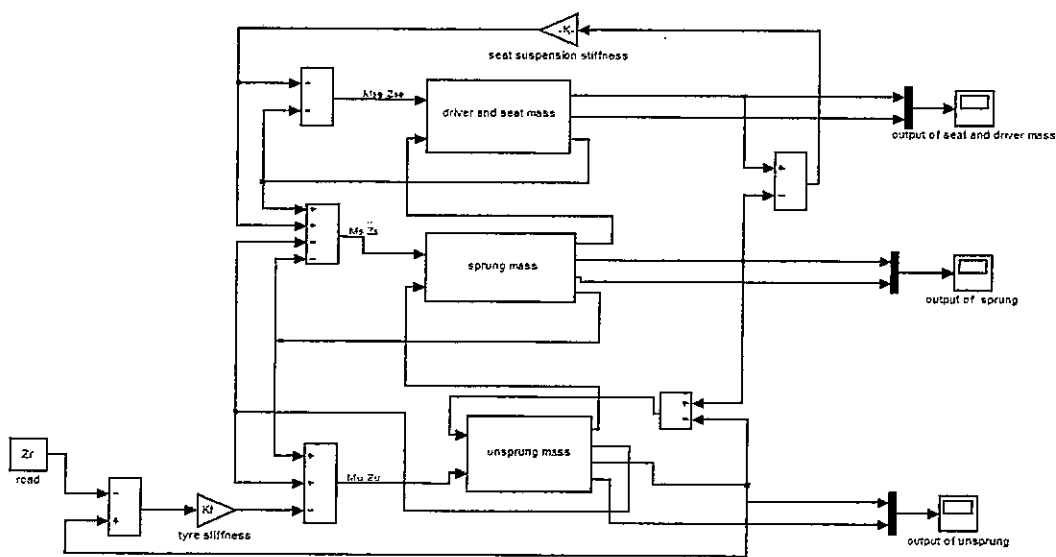

Figure 3: Block diagram of a complete passive Suspension Model

### III. PROPOSED SCHEME

#### A. The active suspension system

The demand of better ride comfort and controllability of road vehicles has motivated many automotive industries to consider the use of active suspension. Active suspension employs pneumatic or hydraulic actuators which in turn creates the desired force in suspension system as shown in Figure 4. The actuator is secured in parallel with spring and shock absorber. Active suspension requires 2 accelerometers that mounted at sprung and unsprung mass, and a unit of displacement transducer to measure the motions of the body, suspension system and the unsprung mass. Active suspension may consume large amounts of energy in providing the control force. Therefore, in the of active suspension system the power consumptions of actuator should also be considered as an important factor. [5]

A two degree of freedom "quarter-car" automotive suspension system is shown in Figure 4. It represents the automotive system at each wheel i.e. the motion of the axle and of the vehicle body at any one of the four wheels of the vehicle. Quarter car model is considered because it is simple and one can observe the basic features of the active suspension system such as a sprung and unsprung mass, suspension deflection and tyre deflection. The suspension is shown to consist of a spring  $k_s$ , a damper  $b_s$  and an active force actuator  $a_f$ .

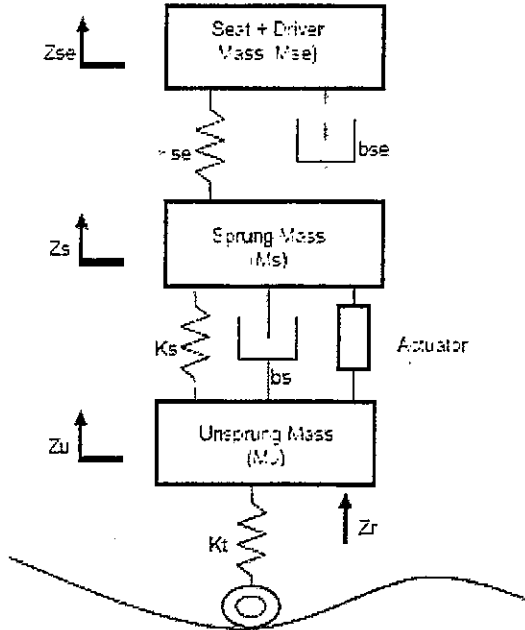

Figure 4: Quarter car model of a suspension system

#### B. Quarter model of active Suspension System

The governing equations of the quarter car suspension system for active suspension system in Figure 4 are presented. The free body diagram for the car model is shown as in Figure 5.

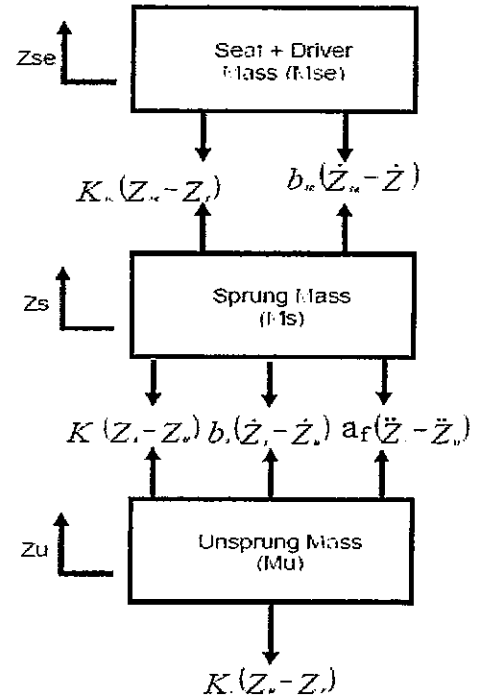

Figure 5: The free body diagram for the car model in active suspension

#### C. Mathematical equation of the free body diagram

The equation of active suspension is been derived based on free body diagram. There are three part of the active suspension which is for drive and seat mass, sprung mass and unsprung mass. The equation of motion from Figure 5 for drive and seat mass is given as below:

$$M_{se} \ddot{Z}_{se} + K_{se}(Z_{se} - Z_s) + b_{se}(\dot{Z}_{se} - \dot{Z}_s) = 0$$

or

$$\ddot{Z}_{se} = -K_{se}(Z_{se} - Z_s) / M_{se} - b_{se}(\dot{Z}_{se} - \dot{Z}_s) / M_{se} \quad (7)$$

Equation of motion for sprung mass as from Figure 5

$$M_s \ddot{Z}_s - K_{se}(Z_{se} - Z_s) - b_{se}(\dot{Z}_{se} - \dot{Z}_s) + K_s(Z_s - Z_u) + b_s(\dot{Z}_s - \dot{Z}_u) + a = 0$$

or

$$\ddot{Z}_s = K_{se}(Z_{se} - Z_s) / M_s + b_{se}(\dot{Z}_{se} - \dot{Z}_s) / M_s - K_s(Z_s - Z_u) / M_s - b_s(\dot{Z}_s - \dot{Z}_u) / M_s - a / M_s \quad (8)$$

Equation of motion for unsprung mass is

$$M_u \ddot{Z}_u - K_s(Z_s - Z_u) - b_s(\dot{Z}_s - \dot{Z}_u) + K_t(Z_u - Z_r) - a_f = 0$$

$$\ddot{Z}_u = K_s(Z_s - Z_u) / M_u + b_s(\dot{Z}_s - \dot{Z}_u) / M_u - K_t(Z_u - Z_r) / M_u + a_f / M_u \quad (9)$$

The active force can be set to zero in a passive suspension. The sprung mass  $M_s$  represents the quarter car equivalent of the vehicle body mass. An unsprung mass  $M_u$  represents the equivalent mass due to axle and tyre. The vertical stiffness of the tyre is represented by the spring,  $k_t$ . The variables  $z_r$ ,  $z_u$  and  $z_r$  represent the vertical displacements from static equilibrium of the sprung mass, unsprung mass and the road respectively. Equations of motion of the two degree of freedom quarter car suspension are given above in equation 7, equation 8, and equation 9.

D. Optimal Controller

The force  $a$  is given by an additional damper with a variable damping factor and takes the form

$$\begin{aligned} a_f &= -b_{se}(t)[\dot{z}_{se} - \dot{z}_s] \\ &= -b_{se}(t)[(\dot{Z}_{se} - \dot{Z}_s)] \\ &= -b_s(t)[(\dot{Z}_{se} - \dot{Z}_s)] \end{aligned} \tag{10}$$

The model of the system becomes a bilinear model with respect to the new control variable  $c(t)$ :

$$\dot{X} = AX + B_c(X)C + G_w \tag{11}$$

In term of physical variables in figure 5, a common criterion to search for a compromise between comfort and road handling can be derived as below:

$$J = \frac{1}{2} \int_0^{\infty} [\dot{z}_2^2 + q_1(z_{se} - z_s)^2 + \dots] dt \tag{12}$$

where  $q_i$  ( $i= 1$  to  $6$ ) are weighting factors design parameters. According to the state model, the criterion can be re-written as below:

$$J = \frac{1}{2} \int_0^{\infty} [X^T Q_n X + X^T Q_r X] dt \tag{13}$$

IV. RESULT AND DISCUSSION

The proposed scheme for suspension system has been simulated in MATLAB/SIMULINK under certain condition and parameters. Table 1 shows the specifications of the system that been used in the simulation, where  $Z_r$ ,  $Z_u$ ,  $Z_s$  and  $Z_{se}$  are the vertical displacement of road, unsprung mass, sprung ass and seat. The output response been simulated for sudden change in

TABLE I. PARAMETERS OF SUSPENSION

Mse	Seat and driver mass	90Kg
Ms	The quarter of the vehicle sprung mass	250Kg
Mu	The quarter of the vehicle unsprung mass	40Kg
Bs	Damping ratio of the vehicle suspension	2000Ns/m
Bse	Damping ratio of the seat suspension	3000Ns/m
Kt	Tire stiffness	125000N/m
Ks	Vehicle suspension spring stiffness	28000N/m
Kse	seat suspension spring stiffness	8000N/m

road profile of 0.2 m height and draw the conclusion.

Figure 6 shows the peak overshoot of seat and driver mass displacement for passive system is equal to 1.5 cm while for the velocity of the system the overshoot is equal to 0.314 cm. Both of the output shows the system for passive suspension

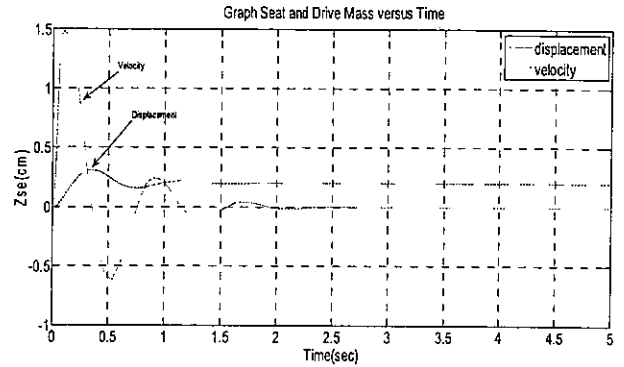

Figure 6 : Seat and Driver Mass versus Time

Figure 7 shows the peak overshoot of sprung mass displacement for passive system is equal to 1.66 cm while for the velocity of the system the overshoot is equal to 0.3 cm.

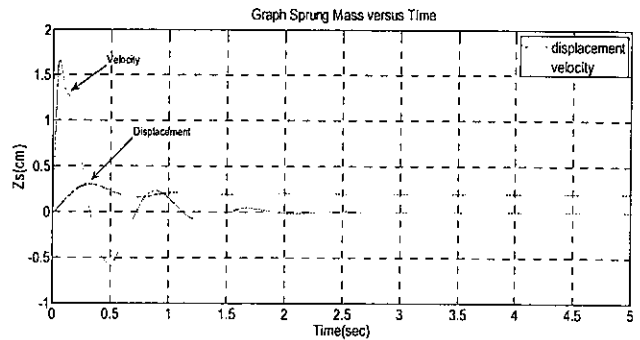

Figure 7: Sprung Mass versus Time

Figure 8 shows the peak overshoot of unsprung mass displacement for passive system is equal to 6.13 cm while for the velocity of the system the overshoot is equal to 0.23 cm.

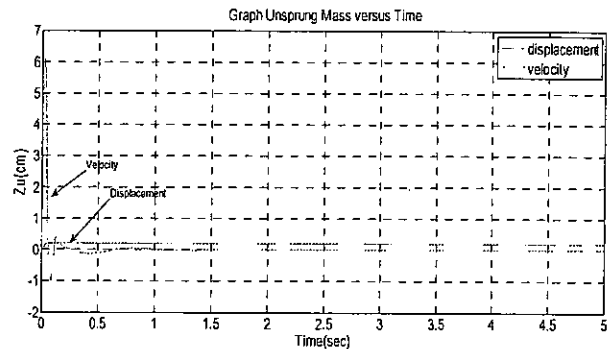

Figure 8: Unsprung Mass versus Time

From Figure 9, peak overshoots of seat and drive mass displacement for passive system is 1.5 cm where as for the active suspension system is 1.07 cm.

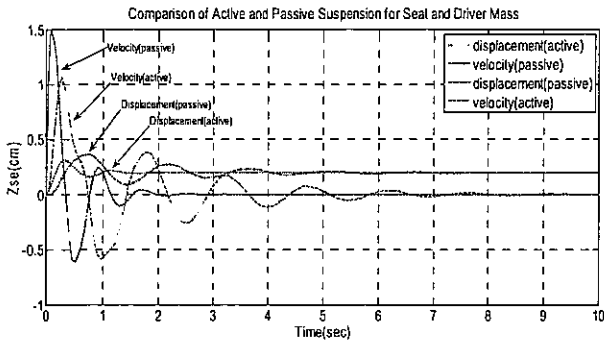

Figure 9: Comparison of active and passive suspension for seat and drive mass

From Figure 10, peak overshoots of sprung mass displacement for passive system is 1.66 cm where as for the active suspension system is 1.03 cm.

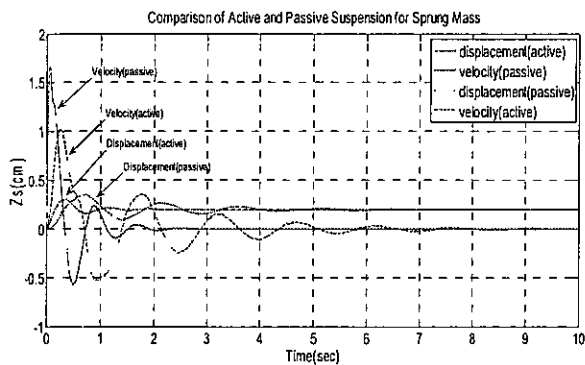

Figure 10: Comparison of active and passive suspension for sprung mass

From Figure 11, peak overshoots of unsprung mass displacement for passive system is 6.13 cm where as for the active suspension system is 2.2 cm.

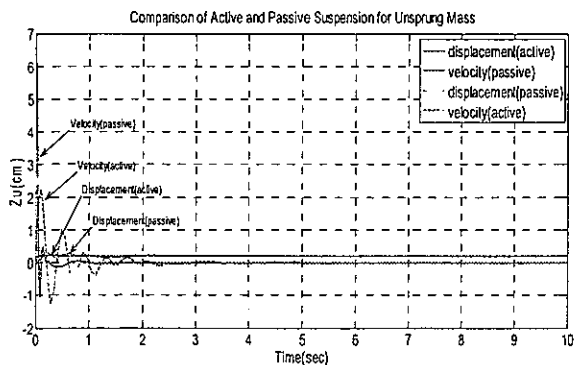

Figure 11: Comparison of active and passive suspension for unsprung mass

## V. CONCLUSION

In this paper, an optimal controller has been designed for a quarter car model of passenger car. Active suspension provides significant improvement in system performance over a purely passive suspension system. The simulation result for optimal controller are extremely encouraging in terms of large improvement in the ride comfort and mobility. Therefore, it is concluded that the active suspension system has better performance capabilities over passive suspension system.

## ACKNOWLEDGMENT

This work has been supported in part by Universiti Teknikal Malaysia Melaka through research project PJP/2009/FKE(1C)S 509, Mat Youb N. , Abd Ghani M. R. , Sakidin H. , and Syed Salim S. N. are with the department of Electrical Engineering of Universiti Teknikal Malaysia Melaka.

## REFERENCES

- [1] Yahaya Md Sam, Modeling and Control of Active Suspension System Using PI Sliding Mode control, Universiti Teknologi Malaysia, PhD Thesis, 2004.
- [2] R. Sharifi Sedeh, M. T. Ahmadian, A. Elahi, R. Saaidpour Azar, Application Of Different Control Approaches To The Design Of Semi-Active Suspension Systems, 2005.
- [3] YOSHIMURA Toshio t, TERAMURA Itaru, Active Suspension Control of a One-wheel Ear Model Using Single Input Rule Modules Fuzzy Reasoning and a Disturbance Observer, The University of Tokushima, Tokushima, 2005.
- [4] Mouleeswaran Senthil Kumar, Development of Active Suspension System for Automobiles using PID Controller, Proceedings of the World Congress on Engineering 2008 Vol II.
- [5] Adizul Ahmad, An Observer Design For Active Suspension System, Universiti Teknologi Malaysia, M.sc Thesis, 2005.
- [6] A. Titli, S. Roukieh, E. Dayre, Three Control Approaches for the Design of Car Semi-Active Suspension, 32<sup>nd</sup> IEEE CDC, San Antonio, 1993.
- [7] T. Yoshimura, A. Nakminami, M. Kurimoto And J. Hino, Active Suspension of Passenger Cars Using Linear and Fuzzy logic Control, Control Engineering Practice, 1994.
- [8] Christophe Lauwerys, Jan Swever, Paul Sas, Robust Linear Control of an Active Suspension System on a Quarter Car Test-rig, Control Engineering Practice.
- [9] Using Car Semi-Active Suspension Systems To Decrease Undesirable Effects Of Road Excitations On Human Health, Sara Sharifi Sedeh, Reza Sharifi Sedeh, Keivan Navi
- [10] T. Yoshimura, A. Kume, M. Kurimoto And J. Hino. (2001), "Construction Of An Active Suspension System Of A Quarter Car Model Using The Concept Of Sliding Mode Control", *Journal Of Sound And Vibration*, Pp 187-199
- [11] Yahaya Md Sam, Johari Halim Shah Osman., And Mohd Ruddin Abd Ghani. ( 2003), "A Class Of Proportional Integral Sliding Mode Control With Application To Active Suspension System", *System And Control Letter*, Pp.217-223
- [12] Design Of a Nonlinear Optimal Controller for Active Suspension System in Order to Vertical Motion Control of Automotive, Ahmad Fakharian, Mohammad Javad Yazdan Panah, Alireza Akhbardeh