

Using Probabilistic Neural Network for Classification High Impedance Faults on Power Distribution Feeders

¹Marizan bin Sulaiman, ²Adnan H. Tawafan and ¹Zulkifilie Bin Ibrahim

¹Faculty of Electrical Engineering, Universiti Teknikal Malaysia Melaka, Melaka, Malaysia

²Foundation of Technical Education, Baghdad, Iraq

Abstract: An intelligent approach probabilistic Neural Network (PNN) combined with advanced signal-processing techniques such as Discrete Wavelet Transform (DWT) is presented for detection High impedance faults (HIFs) on power distribution networks. HIFs detection is usually very difficult using the common over current devices, both frequency and time data are needed to get the exact information to classify and detect no fault from HIF. In this proposed method, DWT is used to extract features of the no fault and HIF signals. The features extracted using DWT which comprises the energy, standard deviation, mean, root mean square and mean of energy of detail and approximate coefficients of the voltage, current and power signals are utilized to train and test the PNN for a precise classification of no fault from HIFs. The proposed method shows that it is more convenient for HIF detection in distribution systems with ample varying in operating cases.

Key words: Discrete Wavelet Transform • High Impedance Fault • Power distribution faults • PNN

INTRODUCTION

Detection of high impedance fault on distribution systems is very hard. It often occurs in power distribution systems and, in general, cannot operate common protection devices because of high impedance, which prevents the fault to draw high current values, at the fault point. These types of faults usually occur, when a distribution line and high impedance surfaces make loose contact or the conductors touch a high impedance object like trees [1]. The primary objective in detection of HIF, in contrast with low impedance faults, is not for the protection of the devices, but to provide public safety and prevent flammable risks because of the electric arcing [2]. HIFs are divided into two types: the passive faults and the active ones. Passive HIFs do not make an electric arc. They are very dangerous to human and animal life since there is no statement of the energisation case of the conductor. Active high impedance faults are usually pursued by arc and draw currents less than the protection devices set [3]. Generally, fault currents are reduced over time until the arc is completely extinct [3]. Most of the methods utilized for detection of HIFs take advantage of fault signals produced by the electric arcing (harmonic and non-harmonic components). While

sometimes the detection system cannot gather enough data to make sure that fault has occurred because the electric arc may vanish before that.

Few other electrical events (capacitor bank operation that uses for improving system stability, power factor correction, voltage profile management and losses minimization[4], air switching operation, nonlinear load and starting induction motor) also behave like the HIF [5], therefore, the algorithm proposed to detect HIF should have the ability to discriminate HIF from other normal events in power distribution system. Most of the detection methods require extensive computation in the reprocessing stage to obtain detection parameters.

During the past decades, protection engineers and researchers have tried to find a complete solution to this type of fault. The fault has many characteristics, like presence of harmonics and high frequency components. Detection techniques aim to identify useful features of HIF from the pattern of the voltage (or current) signals associated. A lot of detection algorithms have been proposed to detect HIF; some of these have used frequency-based algorithm in extraction of features of the harmonic components in relevance [2, 6-9]. Others have utilized time-frequency-based features for examination of the transient operation events of HIF signals in each of

the time and frequency domains [3, 10-17]. The extracted features usually can be obtained after processing the signals with any methods of signal processing such as discrete wavelet transform (DWT), discrete Fourier transform (DFT) and some other time-frequency analysis methods like discrete S-transform (DST), discrete time-time transform (DTT) [3] and the wavelet packet transform (WPT) [17].

A method of detection of HIF based on the nonlinear current behaviour waveforms had proposed in the research work [15], which employs a wavelet multi-resolution signal decomposition method to extract features and an adaptive neural fuzzy inference system (ANFIS) in identifying and classifying purposes. Similarly, principal component analysis and wavelet transform are employed in extracting and selecting features [14]. Moreover, classification is carried out by fuzzy inference system and input membership functions are adjusted by a genetic algorithm. In [18] the author uses (ANFIS) as a classifier to detect HIF. The 3rd harmonics, magnitude and angle, for the 3 phase currents are used as features of HIF. And in [19] The third and fifth harmonic components of the current, voltage and power signals are employed to create feature vector which supplies as input to the Fuzzy ARTMAP Network. This paper represents a HIFs detection method that includes capturing the voltage and current signals produced in a distribution conductor under HIF and non-fault cases. Discrete wavelet transform is used for extraction of the features vector. The findings obtained from this research relate to a typical 13.8-kV, where the known Power Systems CAD PSCAD software is used to attain the faulted signals. A representation of HIF model is involved in this simulation. The system generalization is then tested on presence of HIF signals within a range of different non-fault and fault cases faced in practice.

System Studied

Model of Distribution Feeder: Two 13.8 kV distribution networks were performed in PSCAD/ EMTDC. The first network comprises a substation and three distribution feeders with radial network and the second network represent mesh network. Figure 1 illustrates the schematic diagrams. The generator is of 30 kV and 10 MV connected to the transformer with 30/13.8 kV and 10 MV. The distribution network functions at 13.8 kV voltages. The linear and nonlinear loads with various loading conditions are stimulated. The nonlinear load is represented by 6-pulse rectifier. The selected sampling rate is 12.8 kHz.

Figure 2 illustrates the waveform of HIF current signal under linear and nonlinear loads. The fault has occurred at 0.2 sec. Under linear loading conditions, the HIF signal comprises more harmonic components in contrast with the signal before the fault (Figure 2a). Thus, in these cases, it is easy to distinguish HIF from other normal operations. However, when HIF is under nonlinear loading conditions, the signal before and during the HIF has comprised higher harmonic components (Figure 2b). Consequently, it becomes hard to differentiate HIF from other normal conditions under nonlinear loading conditions and this is a crucial problem in power distribution network. Additionally, it is mandatory to examine the reliability of any HIF method, due to the transient event generated by capacitor bank switching, which produces harmonics like for those that HIF in frequency domain. Many capacitor energisation events have been considered while studying the distribution system.

HIF Simulation: In the past, several HIF models have been presented based on Emanuel arc model. These models have been analyzed by researchers to select the best model for HIF. A simplified Emanuel model proposed in 2003 comprises a pair of DC voltage sources, V_p and V_n , which represent the inception voltage of air in soil and/or between trees and the distribution line. The two varying resistors, R_p and R_n , were used to represent the fault resistance, unequal values allow for asymmetric fault currents to be simulated. When the phase voltage is greater than the positive DC voltage V_p , the fault current flows towards the ground. The fault current reverses when the line voltage is less than the negative DC voltage V_n . For values of the phase voltage between V_n and V_p no fault current flows. A simplified two diode model of HIF, shown in Figure 3 [20].

Probabilistic Neural Network: In 1988, Specht from Lockheed Missiles and Space Company, first proposed a new classification scheme using a new kind of neural networks, which is far different from the traditionally used neural networks trained by backpropagation algorithm [21]. Because of a new type of neural networks has a unique property that under certain easily met conditions, it can asymptotically approach the Bayes optimal decision surface, the PNN classifier was often chosen because the training of PNN is easy and instantaneous, it allows adding or removing the data to the network without need for retraining but only new sample vectors are

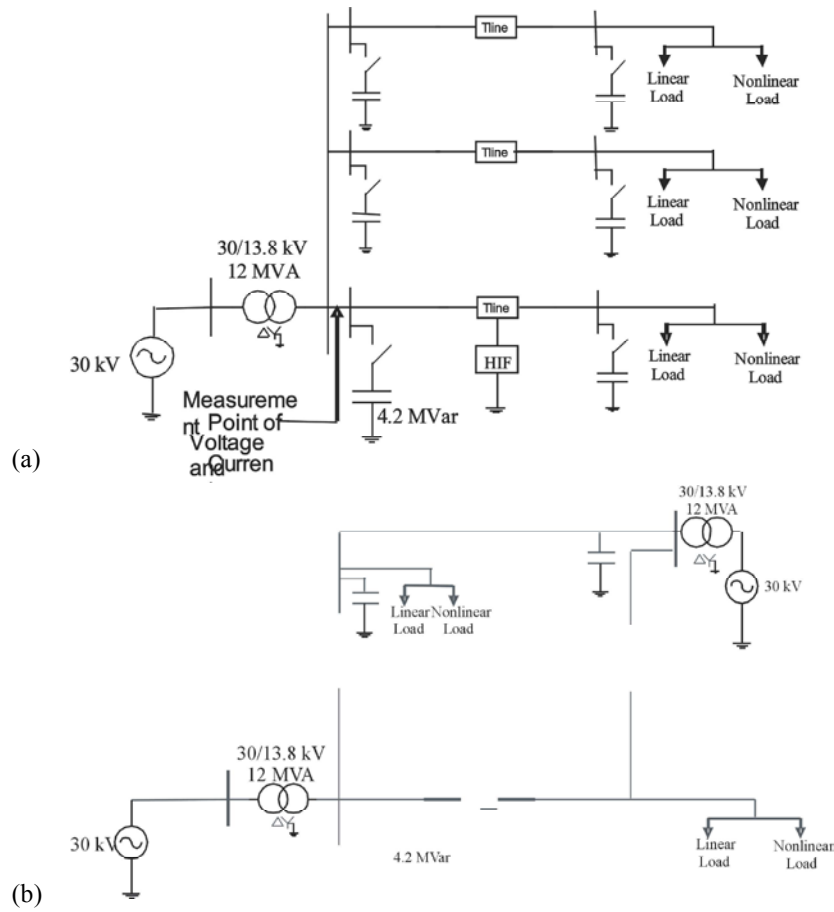

Fig. 1: Graphic Diagram of the Simulated 13.8kV Radial Power System (a) radial network (b) mesh network

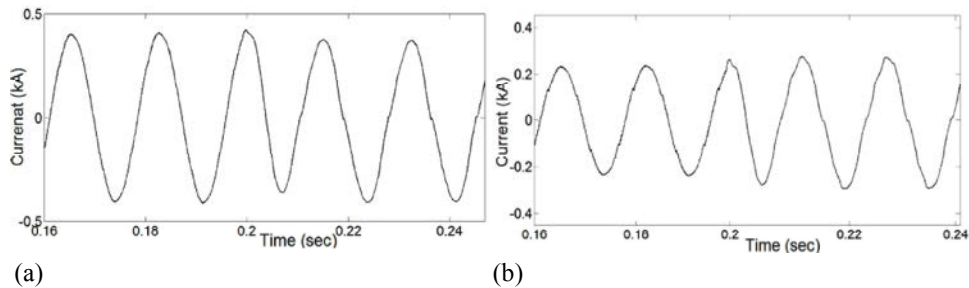

Fig. 2: Typical HIF fault currents (a) HIF current signal (linear load) (b) HIF current signal (nonlinear load).

added into existing weights when training. So it can be used in real-time (Specht & FOR, n.d.). As shown in Figure 4, a PNN networks has four layers:

Input Layer: In the input layer, the number of neurons is equal to number of sample vector. The input layer is totally connected to second layer (The hidden layer), the input layer sends the values of feature vector to each of the neurons in the hidden layer.

Hidden Layer: The second layer is hidden layer or pattern layer that is consisted of some typical sample sets. There is one neuron in the hidden layer for each case in the training input vector. A hidden layer starts to calculate the Euclidean distance of the sample vector from the neuron's center point when it received the x vector of input values from the input layer and then applies the radial basis function using the sigma value (s). Output value of hidden layer is fed to the neurons in the summation layer.

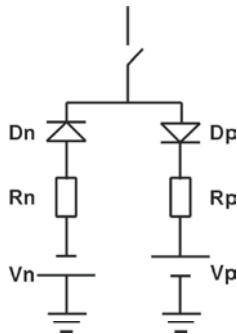

Fig. 3: Model of a high-impedance faults.

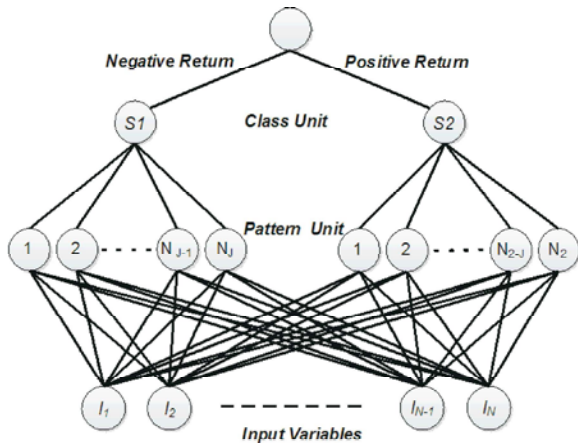

Fig. 4: The architecture of the PNN.

Summation Layer: Summation layer has one neuron corresponding to each particular class classification problem. In this layer the probability of the given input x belonging to class i is computed. A summation layer simply summarizes the outputs of pattern layer neurons which belong to the class it represents to obtain an estimated density function of the class. The Parzen estimate of the probability for input x belonging to class A is given by the probability density function.

$$F_A(x) = \frac{1}{N_k} \sum_{j=1}^{N_k} \exp\left(-\frac{\|x - x_{kj}\|^2}{2\sigma^2}\right) \quad (1)$$

where x is the m dimensional input pattern vector, j is the pattern number, x_j is the j th training pattern for class A , n is the number of training patterns, m is the input space dimension and σ is an adjustable “smoothing parameter.” The parameter σ must be determined experimentally [18].

Decision Layer: The output layer is called decision layer and the number of neurons in it is also equal to the number of classes. The output layer selects the class that

obtains the higher probability in the summation layer. Introduction to Discrete Wavelet Transform (DWT) Discrete Wavelet Transform (DWT) was developed by Mallat [22]. It is a computationally effective way and a common tool to execute time localization of the various frequency components of a given signal. Using DWT, time and frequency resolution of a signal is achieved through the use of some important analyzing functions, named mother wavelets. The most important characteristic of the mother wavelets is that the time intervals are short for high-frequency components, whereas the time intervals are long for low frequency components. The DWT is defined as:

$$DWR(m,k) = \frac{1}{\sqrt{a_0^m}} \sum_n x(n) g\left(\frac{k - nb_0 a_0^m}{a_0^m}\right) \quad (2)$$

where $x(n)$ is the input signal, $g(n)$ is the mother wavelet and the translation and scaling parameters “ b ” and “ a ” are functions of integer parameter m . The result is geometric scaling (i.e. $1, 1/a, 1/a^2, \dots$) and translation by $0, n, 2n, \dots$

Figure 5 depicts implementation of the tree structure of filter-banks for one dimensional DWT, $h[n]$ stands for the low pass filters, where $g[n]$ stands for the high pass filters and the arrows for the down sampling process.

The DWT generates as many wavelet coefficients as there are samples in the original signal, using filter systems. The decomposition procedure begins when a signal passes into these filters. The output of low pass filter is the approximation signal whereas the output of the high pass filter is the detail signal.

Many Wavelet Transform applications for analyzing transient signals of power system have been published lately in the literature. Applications of Wavelet transform for distribution network fault analysis are enriched by some interesting studies and researches. In this paper, different operation conditions have been simulated by using PSCAD/ EMTDC. The current and voltage signals generated in time domain for each case are analyzed using a wavelet transform. A sampling rate of 12.8 kHz is chosen. Daubechies wavelet $Db6$ is selected as the mother wavelet, where it has presented best classification results for fault analysis in power systems. Based on this sampling time, the signal is decomposed into 7 levels. Table 1: Wavelet detail coefficients for 1-7 decomposition levels and approximation level 7 shows the frequency bands range for coefficients up to 7th levels.

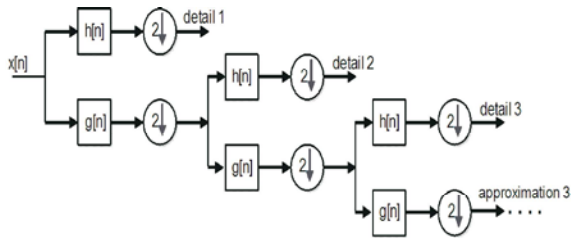

Fig. 5: Implementation of the tree structure of filter-banks for one dimensional DWT

Table 1: Wavelet detail coefficients for 1-7 decomposition levels and approximation level 7

Coefficients	Frequency band (Hz)
d1	3200-6400
d2	1600-3200
d3	800-1600
d4	400-800
d5	200-400
d6	100-200
d7	50-100
a7	0-50

Development of the Proposed Method: The proposed PNN-based method for classification and detection of HIF will be developed based on the following two important parts: features generation and Data preparation.

Features Generation: Different operation conditions (HIF and non-fault cases) have been simulated by using PSCAD/ EMTDC, on the modelled distribution system. The simulated data were then transferred to MATLAB to complete the rest of the algorithm. The main goal of algorithm is to discriminate between HIFs and other similar waveforms.

The DWT is a signal processing tool that provides an understandable representation for transient signals corresponding to a time-frequency plane. The plane gives time-frequency related information about the analysed signal. The signal is decomposed into a hierarchical set of details and approximations. Once the wavelet transform of a signal is performed for each level, wavelet coefficients are obtained and utilized to analyse the signal.

In this study, the process of feature extraction is prepared to attain the highest accuracy of classification, with major data, which can represent the most important properties of the problem. Many investigations and comparisons are made between the performance of PNN with different types of features, like standard deviation (STD), root mean square (RMS), mean, energy and mean

$$STD = \sigma^2 = \sqrt{\left(\frac{1}{n-1} \sum_{i=1}^n \left(x_i - \frac{1}{n} \sum_{i=1}^n x_i \right)^2 \right)} \quad (3)$$

$$RMS = \sqrt{\frac{\sum_{i=1}^n |x_i|^2}{n}} \quad (4)$$

$$MEAN = \frac{\sum_{i=1}^n x_i}{n} \quad (5)$$

$$ENERGY = \sum_{i=1}^n x_i^2 \quad (6)$$

$$MeanENERGY = \frac{\sum_{i=1}^n x_i^2}{n} \quad (7)$$

of energy of each frequency bands (coefficients and signals) levels. The proper features extracted vector (PNN input) is established as follows:

where “x” is the data vector and “n” the number of elements in that data vector. Finally, the standard deviation (STD) of the four levels (4th, 5th, 6th and 7th) of detail coefficients and 7th level of approximation coefficients of the (current, voltage and power) signal is selected to be extracted and used as the input data vector to PNN. For signals sampled at a rate of 12.8 kHz,

The relationship among the features is illustrated in Figure 6 6a, 6b and 6c, each plot represents relation between two features, of which most of the features are distinctive, while some are overlapped. The plots provide information related to the capability of the extracted features for classification in raw feature form, using those features as inputs to the designed PNN.

Data Preparation: Building a probabilistic neural network involves dividing training data into two data sets as follows,

- An input data set which has values for the 15 inputs represent the standard deviation of the 7th level of approximation coefficients and four levels (4th, 5th, 6th and 7th) of detail coefficients of the (current, voltage and power) signals. 1440 input data points were selected from time-frequency plane of current, voltage and power signals. These points were placed into a single input data set.

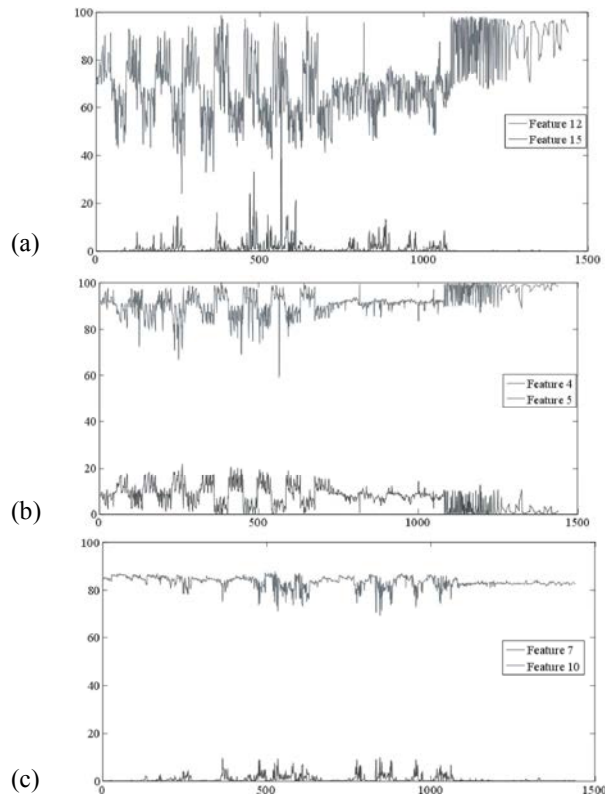

Fig. 6: The relationship among the features (a) relation between features 12 and 15 (b) relation between features 4 and 5 (c) relation between features 7 and 10.

- An output data set which has values for the one output (1 or 10). The output of PNN either 1 for high impedance fault occurs or 10 for other normal event in power system. 1440 output data points in relation with chosen input points were placed into a single output data set.

The remaining 160 input and output data sets, that are dissimilar with the training data, will be employed for the purpose of testing.

RESULTS

After the decomposing process have done, Error! Reference source not found. depicts voltage, current and power decomposing signals under a HIF condition and their detail coefficients at levels 4th, 5th, 6th and 7th and approximate coefficient at level 7th using db6. The effect of the arc period clearly appears by high transient frequencies which can be shown in the Wavelet levels

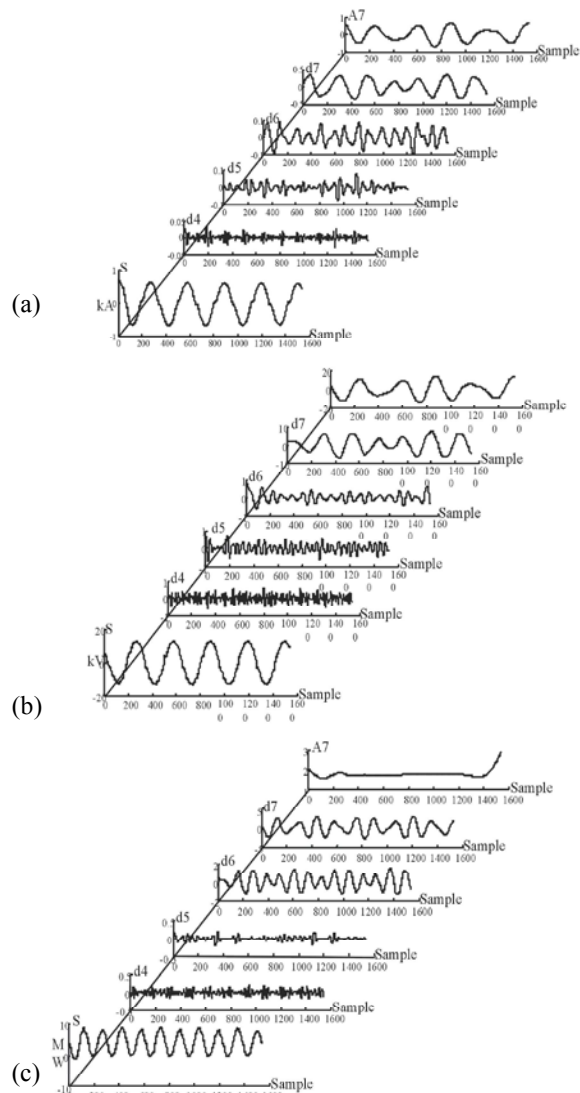

Fig. 7: Decomposing signal under a HIF condition and their detail coefficients at levels 4, 5, 6 and 7 and approximate coefficient at level 7 using db6. a) current signal b) Voltage signal c) power signal

D4 and D5. Error! Reference source not found. shows the behavior of decomposition signals under capacitor operation switching conditions (no fault). According to the figure, any increase or decrease in the values of current doesn't affect the results of the method developed because the part of the signal with high frequency appears only within a short time, when the capacitors bank switches on/off.

There have been 1440 training cases which were selected to train the network. Number of features in each input vector is 15 features, which represents the standard

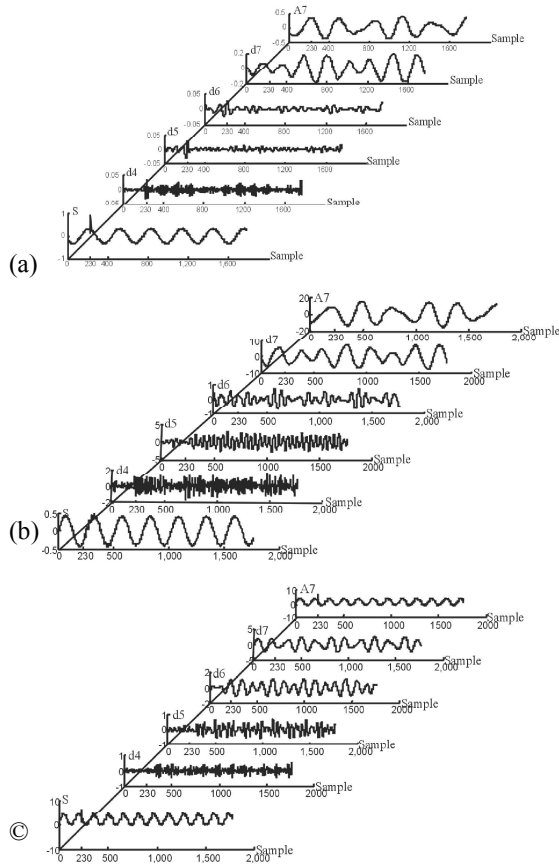

Fig. 8: Decomposing signal under capacitor switching condition and their detail coefficients at levels 4, 5, 6 and 7 and approximate coefficient at level 7 using db6 a) current signal b) Voltage signal c) power signal

deviation of the four levels (4th, 5th, 6th and 7th) of detail coefficients and 7th level of approximation coefficients of the (current, voltage and power) signals. The training sets included 360 HIF cases and the rest are non-fault cases. Different combinations of inputs are used to train and test PNN, to assess the influence on classification rate. The rates of classification are computed on the training and testing data sets.

Table 2: PNN response to training data illustrates output of the PNN to the training data with different type of features, standard deviation (STD), root mean square (RMS), mean, energy and mean of energy of each frequency bands (coefficients and signals) levels. It is found that PNN with STD feature gives better classification rate result, PNN with STD feature provides up to 94.44% and 93.19% classification rate for training data of radial and mesh

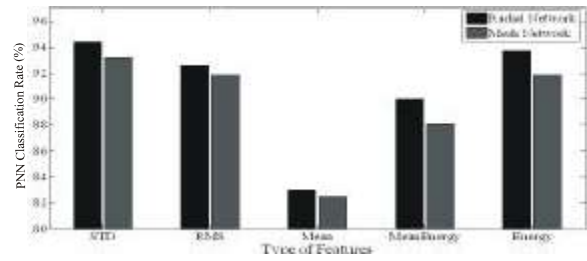

Fig. 9: The classification rate for the different type of features.

Table 2: PNN response to training data

PNN	STD (%)	RMS (%)	Mean (%)	Mean energy (%)	Energy (%)
Radial network	94.44	92.56	82.98	90	93.75
Mesh Network	93.19	91.87	82.5	88.12	91.87

Table 3: PNN response to training data

PNN	STD (%)	RMS (%)	Mean (%)	Mean energy (%)	Energy (%)
Radial network	93.75	91.87	82.5	88.12	91.87
Mesh Network	93.12	89	80.62	87.5	90.62

network respectively. It is obvious that the system is trained properly and has categorized different cases effectively.

To evaluate the suitability of proposed algorithm, test data cases were fed to the PNN and the obtained output is shown in Table 3: PNN response to testing data. It shows that the proposed method could classify different input categories successfully and reliably. PNN with STD feature are capable of categorizing 93.75% and 93.12% classification rate for testing data of radial and mesh network respectively. Results of the testing phase demonstrate that the algorithm is reasonably reliable. Figure 9 show the HIF classification rate of PNN using five types of features.

Furthermore, three goals are selected to validate the method of HIF detection. The first objective is to select a proper mother wavelet to be used in wavelet transform. The second objective is to examine the impact of input feature set on the classification rate performances of the PNN. And finally to investigate the effect of number training data.

Choice of Best Mother Wavelet: Best selection of the mother wavelet represents a major part in detection of various types of signal variations. The selection relies on the application nature. For detection of low amplitude, brief period, rapid decay and oscillating types of signals,

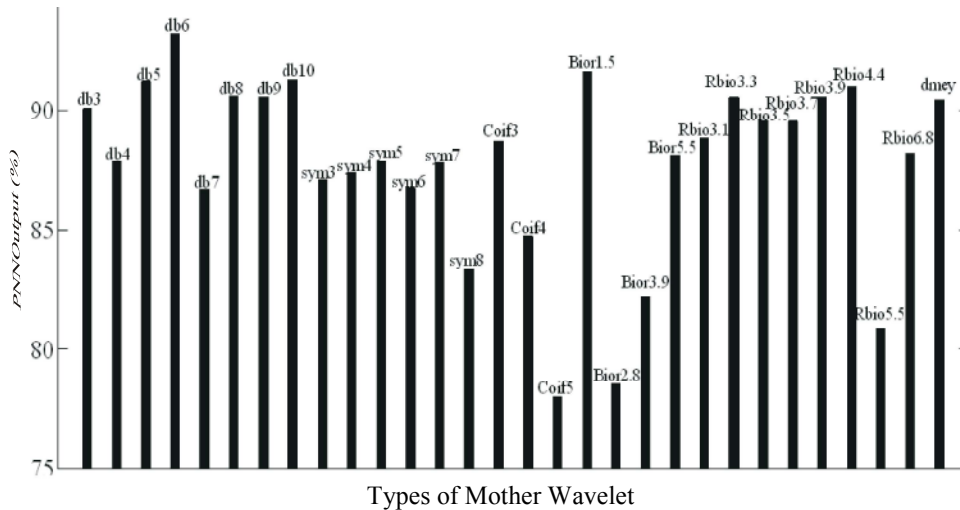

Fig. 10: HIF Classification rate of FSCM using various mother wavelets

Table 4: PNN response to testing data

Feature type	No. of feature
FS1 The STD of the four levels of (current, voltage and power) signal	15
FS2 The STD of the four levels of (current and voltage) signal	10
FS3 The STD of the four levels of (current and power) signal	10

Table 5: The Classification Rate Of Input Feature Set Types

Feature set	Classification rate for	
	Radial Network	Mesh Network
FS1	94.44	93.19
FS2	90.62	81.45
FS3	90.48	79.58

Daubechies and Reverse biorthogonal families mostly used for detecting low amplitude, rapid decay, brief period and oscillating types of signals, (e.g. db2, db3 etc. and rbio2.7, rbio3.7 etc.). Also, smoothness and wideness of mother wavelet relies on its number. So many investigations were done to select the proper wavelet family and its number.

Following a number of investigations, the db6 mother wavelet was chosen. The selection is based on the following reasons:

- As alternatives, 29 types of wavelets were used in training PNN, involving: Daubechie, Symlets, Coiflets, Biorthogonal and Discrete Meyer (dmey) Figure 10.
- The standard used to choose the better mother wavelet was the percentage of classification rate Error! Reference source not found..

- A total of 1440 tests were performed. Simulation results show a high average accuracy of 95.69% that justifies why db6 mother wavelet was selected.

Input Feature Set Types and Their Effect: Various feature sets are investigated to study the impact of input feature set on the classification rate of the PNN. Table 4: Input Feature Set Types illustrates these sets, whereas the Table 5: The Classification Rate Of Input Feature Set Type tabulates the classification rate of the proposed method for each of the sets.

It is evident that generally the FS1 feature sets contain more selective information against other feature sets, as exposed in average classification rate. Also, it can be concluded that the features of the FS1 has shown good results. Figure 11 shows the classification rate for the different feature set.

The Effect of Number Training Data: The proposed PNN is trained and tested with 1600 stimulated cases. Various combinations of inputs are used to test the PNN, to analyze the influence on classification rate. The rates of classification are computed on the training and testing data sets. In this stage, the PNN is trained with different percentage ratio of training and testing data set to get the best classification rate of the PNN. Figure 12 shows the HIF classification rate of PNN with input training data set (FS1) that has different percentage ratio of training and testing data. The maximum classification rate is 95.69% and 93.12% for training and testing data respectively, with 90% of training data and 10% of testing data. However, classification rate is reduced with other percentage ratios of training and testing data.

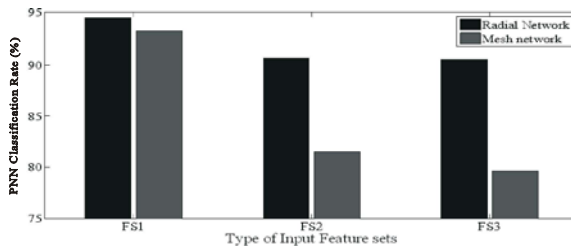

Fig. 11: Classification rate for the different feature set.

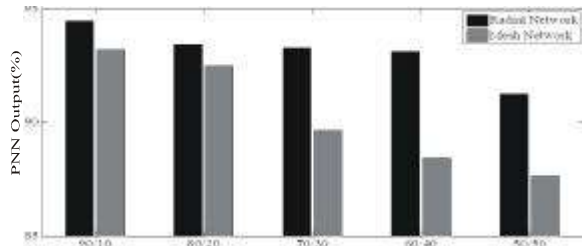

Fig. 12: The HIF classification rate with input training data set (FS1).

DISCUSSION

A qualitative comparison was made among five types of features standard deviation (STD), root mean square (RMS), mean, energy and mean of energy of each frequency bands (coefficients and signals) levels for HIF detection in power distribution feeder, in the proposed algorithm. Based on the outcomes, it was found that the feature of standard deviation (STD) provides better results compared with other features. The classification rate for radial distribution network is 95.69% for feature of FS1 compared with 85.90% and 76.52% for both features of FS2 and FS3, respectively. Furthermore, by using a percentage ratio of 90% training and 10% testing data sets to train and test, the FSCM has given a good classification rate result.

CONCLUSIONS

This study has presented the FSCM for HIF detection and classification. An effort has been made to classify the HIF from other events in distribution system under linear and nonlinear loads. In this paper, the energy of the four levels (4th, 5th, 6th and 7th) of detail coefficients and 7th level of approximation coefficients of the (current, voltage and power) signals, using wavelet transform, are selected to be extracted features and different features like (FS1, FS2 and FS3) were computed and used to train and test the FSCM for the most accurate HIF classification rate. A HIF classification rate of FSCM

higher than 95% is obtained, by using energy of details coefficients of current, voltage and power feature. Ultimately, the proposed approach is quick and precise in identifying HIF and can be extended to guard huge power distribution networks.

ACKNOWLEDGEMENTS

The authors wish to record the utmost appreciation the Faculty of Electrical Engineering, UTeM for providing the required research facilities for this research.

REFERENCES

1. Sedighzadeh, N.I.E.M. and A. Rezazadeh, 2010. "Approaches in High Impedance Fault Detection - A Chronological Review," *Advances in Electrical and Computer Engineering*, 10(3): 114-128.
2. Aucoin, B. and B. Russell, 1982. "Distribution high impedance fault detection utilizing high frequency current components," *IEEE Trans. Power Apparatus and Systems*, PAS-101(6): 1596-1606.
3. Samantaray, P.K., S.R. Panigrahi and B.K. Dash, 2008. "High impedance fault detection in power distribution networks using time-frequency transform and probabilistic neural network," *IET Generation, Transmission & Distribution*, 2(2): 261-270.
4. Argha, A., M.A. Nouri and M. Roopaei, 2011. "Using Fuzzy ILC for Reactive Power Planning in Distribution Systems," *World Applied Sciences Journal*, 13(11): 2263-2270.
5. Mamishev, A.V., B.D. Russell and C.L. Benner, 1996. "Analysis of High Impedance Faults Using Fractal Techniques," *IEEE Transactions on Power Systems*, 11(1): 435-440.
6. Lien, S., K.Y. Chen, S.L. Tzong, C.J.L. Guo, Y. Lin and T.M. Shen, 1999. "Energy variance criterion and threshold tuning scheme for high impedance fault detection," *IEEE Trans. Power Deliv*, 14(3): 810-817.
7. Emanuel, E.M., A.E. Cyganski, D. Orr, J.A. Shiller and S. Gulachenski, 1990. "High impedance fault arcing on sandy soil in 15 kV distribution feeders: contributions to the evaluation of the low frequency spectrum," *IEEE Trans. Power Delivery*, ..., 5(2): 676-686.
8. Kwon, W. and G. Lee, 1991. "High impedance fault detection utilizing incremental variance of normalized even order harmonic power," *IEEE Trans. Power Deliv*, 6(2): 557-564.

9. Russell, R.P., B.D. Mehta and K. Cinchali, 1988. "An arcing fault detection technique using low frequency current components performance evaluation using recorded field data," *IEEE Trans. Power Deliv*, 3(4): 1493-1500.
10. Lazkano, J.A., A. Ruiz, J. Aramendi and E. Gonzalez, 2000. "Study of high impedance fault detection in levante area in Spain," *Proc. Int. Conf. Harmonics and Quality of power*, pp: 1011-1016.
11. Lai, A.G., L.L. Styvaktakis and E. Sichanie, 1998. "Application of discrete wavelet transform to high impedance fault identification," *Proc. Int. Conf. Energy Management and Power Deliveivery*, pp: 689-693.
12. Lai, T.M., L.A. Snider, E. Lo and D. Sutanto, 2005. "High-Impedance Fault Detection Using Discrete Wavelet Transform and Frequency Range and RMS Conversion," *IEEE Trans. Power Deliv*, 20(1): 397-407.
13. Sedighi, M., A.R. Haghifam, M.R. Malik and O.P. Ghassemian, 2005. "High impedance fault detection based on wavelet transform and statistical pattern recognition," *IEEE Trans. Power Deliv*, 20(4): 2414-2421.
14. Haghifam, O.P., M.R. Sedighi and A.R. Malik, 2006. "Development of a fuzzy inference system based on genetic algorithm for high-impedance fault detection," *Generation, Transmission & ...*, 153(3): 359-367.
15. Etemadi, A. and M. Sanaye-Pasand, 2008. "High-impedance fault detection using multi-resolution signal decomposition and adaptive neural fuzzy inference system," *Generation, Transmission & ...*, 2(1): 110-118.
16. Michalik, S.H., M. Lukowicz, M. Rabizant, W. Lee and S.J. Kang, 2008. "New ANN-based algorithms for detecting HIFs in multigrounded MV networks," *IEEE Trans. Power Deliv*, 23(1): 58-66.
17. Ghaffarzadeh, N. and B. Vahidi, 2010. "A New Protection Scheme for High Impedance Fault Detection using Wavelet Packet Transform," *Advances in Electrical and Computer Engineering*, 10(3): 17-20.
18. Abdel Aziz, M.S., M.A. Moustafa Hassan and E.A. Zahab, 2011. "Applications of ANFIS in high impedance faults detection and classification in distribution networks," 8th *IEEE Symposium on Diagnostics for Electrical Machines, Power Electronics & Drives*, pp: 612-619.
19. Saleem, S. and A. Sharaf, 2008. "A fuzzy ARTMAP based high impedance arc fault detection scheme," in *Electrical and Computer Engineering, 2008. CCECE 2008. Canadian Conference on*, pp: 871-876.
20. Lai, T., L. Snider and E. Lo, 2003. "Wavelet transform based relay algorithm for the detection of stochastic high impedance faults," *International Conference on Power Systems Transients*, 1(1): 1-6.
21. Specht, D.F. and P.N.N. FOR, "Probabilistic Neural Networks for Classification, Mapping, Or Associative Memory." in *Proceedings of IEEE International Conference on Neural Networks*, Vol.1, IEEE Press, New York, pp: 525-532.
22. Mallat, S., 1989. "A Theory for Multiresolution Signal Decomposition: The Wavelet Representation," *IEEE Transactions on Pattern Analysis and Machine Intelligence*, 1(7): 674-693.